



Manufacturers of **Presentation**,  
**Display** and **Furniture** Products

# contents

## Welcome to our latest Display, Presentation and Furniture catalogue.

We continue to offer a wide selection of products across 12 popular categories. Each product category offers you a wide choice of Designs, Colours and Sizes to meet your requirements for both application and style.

This year we are introducing many new products, contemporary colourways as well as a brand new range of ColourBox® tray storage solutions. Our most popular products are in stock available for immediate dispatch, others are made to order to your requirements.

### Noticeboards

<b>4 - 7</b>	Frameless Noticeboards
<b>8 - 15</b>	Aluminium Framed Noticeboards
<b>16 - 23</b>	Shield® Design Noticeboards
<b>24 - 30</b>	Eco-friendly Noticeboards
<b>31</b>	Eco-friendly Lockable Noticeboards
<b>31 - 38</b>	Lockable Noticeboards
<b>39 - 44</b>	Shield® Tamperproof Noticeboards
<b>45 - 51</b>	Shield® Showcases
<b>52 - 55</b>	Shield® Exterior Showcases
<b>54 - 58</b>	Freestanding Noticeboards
<b>59 - 61</b>	Mobile Noticeboards
<b>62 - 64</b>	Colour Swatches

### WriteOn® Whiteboards

<b>66 - 67</b>	Coloured Edge Whiteboards
<b>68 - 71</b>	Aluminium Framed Whiteboards
<b>72 - 73</b>	Shield® Design Whiteboards
<b>74</b>	Eco-friendly Whiteboards
<b>75 - 76</b>	Glass Drywipe Boards
<b>76 - 77</b>	Projection Whiteboards
<b>78 - 80</b>	Mobile Whiteboards
<b>81</b>	Freestanding Whiteboards
<b>82 - 83</b>	Printed Whiteboards
<b>84 - 85</b>	Drywipe Planners
<b>86 - 87</b>	Drywipe Sports Boards
<b>83, 88</b>	Drywipe Maps
<b>89 - 92</b>	Whiteboard Accessories

### Literature Display

<b>126 - 127</b>	Coloured Displays
<b>128 - 131</b>	Clear Acrylic Displays
<b>132 - 133</b>	Clear Acrylic Desktop Displays
<b>134 - 135</b>	Shelf Style Displays
<b>136 - 138</b>	Wooden Displays
<b>139 - 142</b>	Steel Mesh Displays
<b>142 - 143</b>	Steel Displays
<b>144 - 145</b>	Steel Wire Displays
<b>146</b>	Brochure Stackers

### Exhibition and Display

<b>148 - 151</b>	BusyFold® Light Folding Systems
<b>152 - 153</b>	BusyFold® Heavy Duty Folding Systems
<b>154</b>	BusyFold® One Piece Folding Systems
<b>155 - 157</b>	MightyBoard Expandable Systems
<b>158</b>	OnBoard Expandable Systems
<b>159</b>	Multi-Board Expandable Systems
<b>160</b>	Accessories
<b>160</b>	Colour Swatches

### Audio Visual Furniture

<b>194</b>	Projector Stands
<b>195 - 198</b>	Locking Projector Cabinets
<b>198 - 201</b>	Locking TV Cabinets
<b>202</b>	Mobile TV Stands

### Projection Screens

<b>204 - 205</b>	Freestanding Tripod
<b>206 - 209</b>	Freestanding
<b>210 - 212</b>	Wall Mounted Manual
<b>213 - 221</b>	Wall Mounted Electric
<b>222</b>	Accessories
<b>223</b>	Fixed Frame
<b>224 - 225</b>	Drywipe
<b>226</b>	Bespoke Screen Service

We are pleased to announce that many products contained within this catalogue are now available within the National Building Specification database making it easy for you to specify our range when working with architects and specifiers.

**nbsPlus**

## Flipchart Easels and Rail Systems

<b>94</b>	Tripod Easels
<b>95</b>	Mobile Easels
<b>96 - 97</b>	Coloured Ultimate Easels
<b>98</b>	Conference Pro Easel
<b>99</b>	Combi Mobile Easel
<b>100 - 101</b>	BusyRail®
<b>102</b>	Trapease Flipchart Hanger
<b>102</b>	Flipchart Accessories

## Poster Display and Signage

<b>104 - 109</b>	Wall Mounted Poster Display
<b>110 - 114</b>	Freestanding Poster Display
<b>114 - 115</b>	Freestanding WriteOn® Signage
<b>116 - 117</b>	Wall Mounted WriteOn® Signage
<b>118</b>	WriteOn® Whiteboard Stands
<b>118 - 119</b>	In-Out Boards
<b>120</b>	Desk Top Signage
<b>120 - 124</b>	Wall Mounted Signage

## BusyScreen® Partitions

<b>162 - 163</b>	BusyScreen® Curve
<b>164 - 165</b>	BusyScreen® Classic
<b>166</b>	BusyScreen® Triple Safety
<b>167</b>	BusyScreen® Accessories
<b>168 - 169</b>	BusyScreen® Carnival
<b>170 - 171</b>	BusyScreen® Connect
<b>172 - 173</b>	Colour Swatches
<b>174</b>	Barriers

## Meeting Room Furniture

<b>176 - 180</b>	Tables
<b>181 - 183</b>	Chairs
<b>184 - 185</b>	Lecterns
<b>186 - 187</b>	Glazed Display Cases
<b>188</b>	Uplighter
<b>188 - 189</b>	Clocks
<b>190 - 191</b>	Coat Stands
<b>192</b>	Coat Hooks

## Junior Products

<b>228</b>	Whiteboards
<b>229</b>	Laptop Whiteboards
<b>230</b>	Desktop Easels
<b>231 - 232</b>	Mobile Easels
<b>232</b>	Paper Hanger
<b>233 - 234</b>	Partition Screens

## ColourBox® Storage Furniture

<b>236</b>	How to Order
<b>237</b>	Colour Swatches
<b>238 - 240</b>	Tray Units
<b>241 - 243</b>	Tub Units
<b>244 - 245</b>	Kinderboxes
<b>246 - 247</b>	Quadrant Units
<b>248 - 250</b>	Locking Cabinets
<b>251</b>	Tubs
<b>252</b>	Trays



# stock and delivery

Decades of experience have resulted in an unrivalled range with most products available ex-stock.

Our simple yet effective part number coding system gives an immediate indication to our stock lines.

All product numbers in the catalogue are colour coded for delivery and stock status

## Key to delivery and stock colour codes:

**Black** Shipped from stock

**Purple** Ex stock but requires special transport

**Green** Made to order

**Blue** Made to order

All products carry a minimum 12 month guarantee - more in some cases. Our policy is one of continuous improvement, therefore we reserve the right to alter the design or specification of a product without notice. Metroplan claim their right as publishers of the copyright to this catalogue, therefore no content can be reproduced without their written consent. E&OE.

# Noticeboards

- 4 - 7 Frameless Noticeboards
- 8 - 15 Aluminium Framed Noticeboards
- 16 - 23 Shield® Design Noticeboards
- 24 - 30 Eco-friendly Noticeboards
- 31 Eco-friendly Lockable Noticeboards
- 31 - 38 Lockable Noticeboards
- 39 - 44 Shield® Tamperproof Noticeboards
- 45 - 51 Shield® Showcases
- 52 - 55 Shield® Exterior Showcases
- 54 - 58 Freestanding Noticeboards
- 59 - 61 Mobile Noticeboards
- 62 - 64 Colour Swatches



# Noticeboards - Frameless



UNB64/DB

## Frameless felt covered noticeboards

### A range of standard felt noticeboards

Can be mounted portrait or landscape. Mounts through the board, fixings supplied. Quality pinnable and Velcro® friendly noticeboard covered with traditional felt cloth. 3 larger sizes are supplied in 2 parts. Available in a choice of 5 colours.

For Aluminium Framed version - see page 8

### TO ORDER:

Please state the product code followed by the colour code of the cloth required.

EXAMPLE: 1200 x 1500mm in red felt = **UNB54/RD**



[www.metroplan-ecofriendly.co.uk](http://www.metroplan-ecofriendly.co.uk)



Size H 600mm  
W 900mm  
Felt **UNB32**

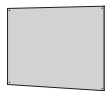

Size H 900mm  
W 1200mm  
Felt **UNB43**



Size H 1200mm  
W 1200mm  
Felt **UNB44**

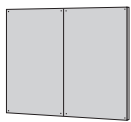

Size H 1200mm  
W 1500mm  
Felt **UNB54**

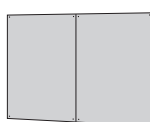

Size H 1200mm  
W 1800mm  
Felt **UNB64**

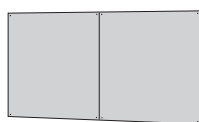

Size H 1200mm  
W 2400mm  
Felt **UNB84**

### Felt cloth colours - see page 62



Blue



Burgundy



Red



Green



Grey



UNB54/RD



Through the board fixing



# NEW Frameless ColourPlus noticeboards

ColourPlus range features 6 vibrant and contemporary colourways

New range of noticeboards offering a range of bright contemporary cloth colour finishes. ColourPlus offers a selection of 6 fabric colours and is designed for use with pins. Can be mounted portrait or landscape. Mounts through the board, fixings supplied. 3 larger sized boards are supplied in 2 parts for easier installation.

For Aluminium Framed version - see page 9

**TO ORDER:**

Please state the product code followed by the colour code of the cloth required.

EXAMPLE: 900 x 1200mm in orange felt = **UCP1290/OR**



UCP1290/OR



[www.metroplan-ecofriendly.co.uk](http://www.metroplan-ecofriendly.co.uk)

**ColourPlus fabric colours** - see page 62

Purple	Magenta	Lilac
Orange	Cyan	Apple



Size H 600mm  
W 900mm  
Felt **UCP9060**



Size H 900mm  
W 900mm  
Felt **UCP9090**

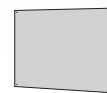

Size H 900mm  
W 1200mm  
Felt **UCP1290**

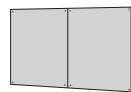

Size H 900mm  
W 1500mm  
Felt **UCP1590**



Size H 900mm  
W 1800mm  
Felt **UCP1890**



Size H 900mm  
W 2400mm  
Felt **UCP2490**

UCP1290/AG

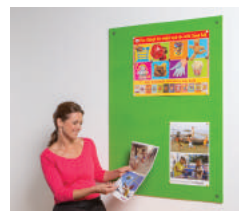

Look out for many other ColourPlus products



# Noticeboards - Frameless



URF64/SL

## NEW Frameless Resist-a-Flame® class 0 noticeboards

A range of fully tested fire resistant noticeboards

Can be mounted portrait or landscape. Mounts through the board, fixings supplied. Quality pinnable noticeboard covered with fire resistant woven cloth. 3 larger sizes are supplied in 2 parts. Constructed and tested to meet the latest building and fire regulations. Ideal for use in public buildings and commercial applications. Fully assembled board certified to BS EN 13501. Available in a wide choice of 11 woven cloth colours.

For Aluminium Framed version - see page 11

### TO ORDER:

Please state the product code followed by the colour code of the cloth required.

EXAMPLE: 1200 x 1800mm in silver grey cloth = **URF64/SL**



Size H 600mm  
W 900mm  
Felt **URF32**

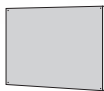

Size H 900mm  
W 1200mm  
Felt **URF43**



Size H 1200mm  
W 1200mm  
Felt **URF44**

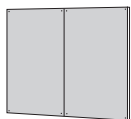

Size H 1200mm  
W 1500mm  
Felt **URF54**



Size H 1200mm  
W 1800mm  
Felt **URF64**



Size H 1200mm  
W 2400mm  
Felt **URF84**

Look out for many other Resist-a-Flame® products



Resist-a-Flame® woven cloth colours - see page 63



**FIRE RESISTANT RESISTAFLAME**

**Standard or Resist-a-Flame?**  
Do you comply with public area building regulations?  
go to: [www.resistaflame.com](http://www.resistaflame.com)

**NEW EUROPEAN REACTION TO FIRE TEST**  
When tested to the relevant European 'Reaction to Fire' tests, this product was classified B-S1, d0 according to BS-EN 13501-1.  
This classification identifies that this product can be used in the same areas as products tested to BS476 Parts 6 and 7 and classified as class 0 according to UK building regulations.



# Frameless recycled noticeboards

A range of coloured noticeboards made from recycled waste newsprint

This board has no fabric covering and is suitable for use with pins. Can be mounted portrait or landscape. Fixings supplied. Available in a choice of 6 colours.

For Aluminium Framed version - see page 12

**TO ORDER:**

Please state the product code followed by the colour code of the board required.

EXAMPLE: 1200 x 1500mm in lilac = **UFC54/LC**

**NOTE:**

No fabric - for use with pins only



UFC54/LC



[www.metroplan-ecofriendly.co.uk](http://www.metroplan-ecofriendly.co.uk)

**Pinnable colourboard colours** - see page 62



Blue Red Green Lilac Natural Charcoal



Size H 600mm  
W 900mm  
Colourboard **UFC32**

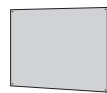

Size H 900mm  
W 1200mm  
Colourboard **UFC43**



Size H 1200mm  
W 1200mm  
Colourboard **UFC44**



Size H 1200mm  
W 1500mm  
Colourboard **UFC54**



Size H 1200mm  
W 1800mm  
Colourboard **UFC64**



Size H 1200mm  
W 2400mm  
Colourboard **UFC84**



UFC54/LC



Through the board fixing



# Noticeboards - Aluminium Framed



44554/DB

## Aluminium framed felt noticeboards

Best selling range of standard felt covered noticeboards with aluminium framing and round safety corners

Can be mounted portrait or landscape. Mounts through concealed corners, fixings supplied. Quality noticeboard in a choice of five felt colours for use with pins or Velcro®.

### TO ORDER:

Please state the product code followed by the colour code of the cloth required.

EXAMPLE: 1200 x 1500mm in blue felt = **44554/DB**



FOR WHITEBOARDS - SEE PAGE 69-71



Size H 600mm  
W 450mm  
Code **44531**



Size H 900mm  
W 600mm  
Code **44532**



Size H 1200mm  
W 900mm  
Code **44543**



Size H 1200mm  
W 1200mm  
Code **44544**

### Standard felt cloth colours - see page 62

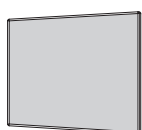

Size H 1200mm  
W 1500mm  
Code **44554**

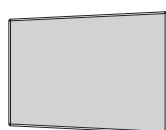

Size H 1200mm  
W 1800mm  
Code **44564**



Size H 1200mm  
W 2400mm  
Code **44584**

44544/RD



Concealed corner fixing



## ColourPlus noticeboards

ColourPlus range features 6 vibrant and contemporary colourways

New range of noticeboards offering a range of bright contemporary cloth colour finishes. ColourPlus offers a selection of 6 fabric colours and is designed for use with pins. Standard aluminium frame is supplied complete with fixings and concealed corner mounting.

For Shield® Design version with white frame - see page 16

### TO ORDER:

Please state the product code followed by the colour code of the board required.

EXAMPLE: 900 x 1200mm in Orange = **PS1290/OR**

ColourPlus fabric colours - see page 62

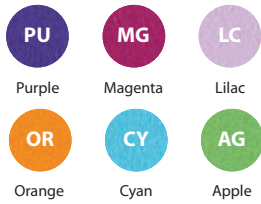

## ColourPlus



Size H 600mm  
W 300mm  
Code **PS3060**

Also available in packs of 3



Size H 900mm  
W 300mm  
Code **PS3090**

Also available in packs of 3



Size H 600mm  
W 450mm  
Code **PS4560**

Also available in packs of 3



Size H 600mm  
W 900mm  
Code **PS9060**



PS1590/LC

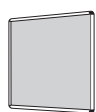

Size H 900mm  
W 900mm  
Code **PS9090**

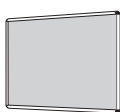

Size H 900mm  
W 1200mm  
Code **PS1290**

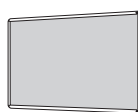

Size H 900mm  
W 1500mm  
Code **PS1590**

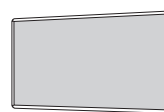

Size H 900mm  
W 1800mm  
Code **PS1890**



Size H 900mm  
W 2400mm  
Code **PS2490**

Concealed corner fixing



# Noticeboards - Aluminium Framed

66554/DB



## Aluminium framed noticeboard with fire retardant cloth

Fabric tested to BS5867 Part 2 2008; Type B

Can be mounted portrait or landscape. Mounts through concealed corner fixings. These aluminium framed noticeboards use the same attractive display stitchbond fabric as our Resist-a-Flame® range but with a standard fibreboard core. The fabric is individually tested to BS5867 Part 2 2008; Type B curtains, drapes and blinds. These boards are for use in non-sensitive areas. For all other areas i.e. fire escapes, stairwells, lobbies etc. see Resist-a-Flame® on opposite page.

### TO ORDER:

Please state the product code followed by the colour code of the cloth required.

EXAMPLE: 1200 x 1500mm in dark blue = **66554/DB**



Size H 900mm  
W 600mm  
Code **66532**



Size H 1200mm  
W 900mm  
Code **66543**

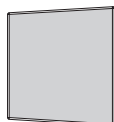

Size H 1200mm  
W 1200mm  
Code **66544**

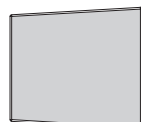

Size H 1200mm  
W 1500mm  
Code **66554**



Size H 1200mm  
W 1800mm  
Code **66564**



Size H 1200mm  
W 2400mm  
Code **66584**

Range of woven cloth colours - see page 63



Concealed corner fixing



## Resist-a-Flame® class 0 aluminium framed noticeboards

A range of class 0 fire-resistant noticeboards with aluminium framing

Market leading range of fire retardant noticeboards fully constructed and independently tested to meet the latest building and fire regulations. Ideal for use in public buildings and commercial applications. Fully assembled board certified to BS EN 13501. Available in a wide choice of 11 woven cloth colours. Can be mounted portrait or landscape. Mounts through concealed corners, fixings supplied.

### TO ORDER:

Please state the product code followed by the colour code of the cloth required.

EXAMPLE: 1200 x 1200mm in Crimson = **45401/CR**



45401/CR



**Standard or Resist-a-Flame?**  
Do you comply with public area building regulations?  
go to: [www.resistaflame.com](http://www.resistaflame.com)

**NEW EUROPEAN REACTION TO FIRE TEST**  
When tested to the relevant European 'Reaction to Fire' tests, this product was classified B-SI, d0 according to BS-EN 13501-1.  
This classification identifies that this product can be used in the same areas as products tested to BS476 Parts 6 and 7 and classified as class 0 according to UK building regulations.

Recommended for corridor use



Size H 900mm  
W 600mm  
Code **45381**



Size H 1200mm  
W 900mm  
Code **45391**

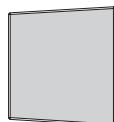

Size H 1200mm  
W 1200mm  
Code **45401**

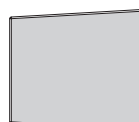

Size H 1200mm  
W 1500mm  
Code **45441**



Size H 1200mm  
W 1800mm  
Code **45411**



Size H 1200mm  
W 2400mm  
Code **45421**

Concealed corner fixing



Resist-a-Flame® woven cloth colours - see page 63  
**Stocked range**



Dk Blue    Crimson    Conifer    Silver    Plum

**Extended range - made to order**  
Please allow for a slightly longer delivery time



Lt Blue    Grey Green    Ebony    Charcoal    Caspian    Mustard

# Noticeboards - Aluminium Framed



FCB54/BL

## Aluminium framed recycled noticeboards

A range of coloured noticeboards made from recycled waste newsprint with aluminium framing

This board has no fabric covering and is suitable for use with pins. Can be mounted portrait or landscape. Mounts through concealed corners, fixings supplied. Available in a choice of 6 colours.

### TO ORDER:

Please state the product code followed by the colour code of the board required.

EXAMPLE: 1200 x 1500mm in blue = **FCB54/BL**

### NOTE:

No fabric - for use with pins only



Size H 900mm  
W 600mm  
Code **FCB32**



Size H 1200mm  
W 900mm  
Code **FCB43**

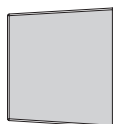

Size H 1200mm  
W 1200mm  
Code **FCB44**

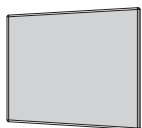

Size H 1200mm  
W 1500mm  
Code **FCB54**

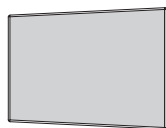

Size H 1200mm  
W 1800mm  
Code **FCB64**



Size H 1200mm  
W 2400mm  
Code **FCB84**

Pinnable recycled board colours - see page 62



[www.metroplan-ecofriendly.co.uk](http://www.metroplan-ecofriendly.co.uk)



Concealed corner fixing



FCB54/BL





44543/CK

## Aluminium framed cork noticeboards

A range of traditional cork surface noticeboards with aluminium framing and rounded safety corners.

Can be mounted portrait or landscape. Mounts through concealed corners, fixings supplied. Quality pinnable cork surface. Available in 7 popular sizes.



Size H 600mm  
W 450mm  
Code **44531/CK**



Size H 900mm  
W 600mm  
Code **44532/CK**



Size H 1200mm  
W 900mm  
Code **44543/CK**

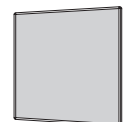

Size H 1200mm  
W 1200mm  
Code **44544/CK**

Concealed corner fixing

44532/CK

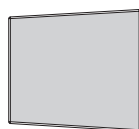
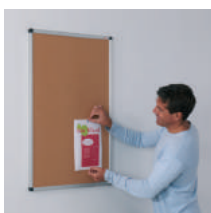

Size H 1200mm  
W 1500mm  
Code **44554/CK**

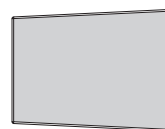

Size H 1200mm  
W 1800mm  
Code **44564/CK**



Size H 1200mm  
W 2400mm  
Code **44584/CK**

# Noticeboards - Aluminium Framed



TH9060/DB

## ThemeBoard noticeboards

Add your Club name, House or Department to these open noticeboards

New range of noticeboards with a 200mm deep drywipe surface header. This enables you to state the Theme or subject of the notices to be displayed by either drywipe pen or applying lettering or customised graphics for a professional finish. Boards have an aluminium frame with concealed corner fixings. Available in a choice of 6 popular sizes. Pinnable surface available in 5 felt colours or traditional cork.

For lockable versions - see page 38

### TO ORDER:

Please state the product code followed by the colour code of the board required.

EXAMPLE: Standard Felt 900 x 600mm in Blue = **TH9060/DB**

### NOTE:

Graphic service is available - ask for details



TH1812/LG



Size H 900mm  
W 600mm  
Code **TH9060**



Size H 1200mm  
W 900mm  
Code **TH1290**

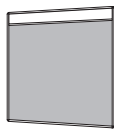

Size H 1200mm  
W 1200mm  
Code **TH1212**

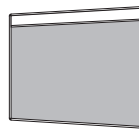

Size H 1200mm  
W 1500mm  
Code **TH1512**

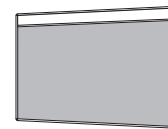

Size H 1200mm  
W 1800mm  
Code **TH1812**

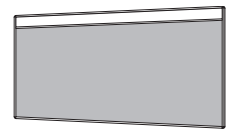

Size H 1200mm  
W 2400mm  
Code **TH2412**

### Felt cloth colours - see page 62

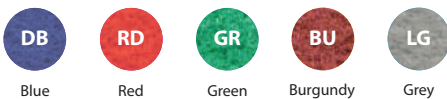

### Traditional cork



### Concealed corner fixing





## Aluminium framed felt/drywipe dual noticeboards

Combination pinnable notice and drywipe board

Aluminium framed combination board with half whiteboard, complimented by a choice of five felt colours for the noticeboard surface.

**TO ORDER:**

Please state the product code followed by the colour code of the cloth required.

EXAMPLE: 900 x 1200mm in red = **D4555/RD**

Felt cloth colours - see page 62



Size H 600mm  
W 900mm  
Code **D4554**

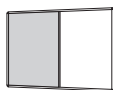

Size H 900mm  
W 1200mm  
Code **D4555**

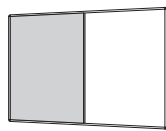

Size H 1200mm  
W 1800mm  
Code **D4556**



Dual red felt noticeboard D4555/RD



Dual cork noticeboard D4554/CK



## Aluminium framed cork/drywipe dual noticeboards

Combination pinnable notice and drywipe board

Aluminium framed combination board with half whiteboard, complimented by a traditional cork noticeboard surface.



Size H 600mm  
W 900mm  
Code **D4554/CK**

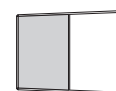

Size H 900mm  
W 1200mm  
Code **D4555/CK**

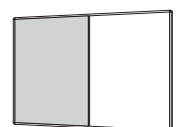

Size H 1200mm  
W 1800mm  
Code **D4556/CK**

# Noticeboards - Shield® Design



PD2490/OR

## Shield® Design ColourPlus noticeboards

New range of noticeboards offering a range of bright contemporary cloth colour finishes

ColourPlus offers a selection of 6 fabric colours and is designed for use with pins. Shield® Design white frame is supplied complete with fixings and concealed corner mounting. Can be mounted portrait or landscape.

For standard aluminium framed version - see page 9

### TO ORDER:

Please state the product code followed by the colour code of the board required.

EXAMPLE: Shield® white trim 900 x 2400mm in Orange = **PD2490/OR**

ColourPlus fabric colours - see page 62



Size H 600mm  
W 300mm  
Code **PD3060**

Also available in packs of 3

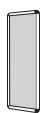

Size H 900mm  
W 300mm  
Code **PD3090**

Also available in packs of 3



Size H 600mm  
W 450mm  
Code **PD4560**

Also available in packs of 3



Size H 600mm  
W 900mm  
Code **PD9060**



PD9060/PU

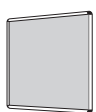

Size H 900mm  
W 900mm  
Code **PD9090**

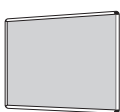

Size H 900mm  
W 1200mm  
Code **PD1290**

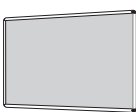

Size H 900mm  
W 1500mm  
Code **PD1590**

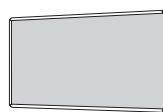

Size H 900mm  
W 1800mm  
Code **PD1890**

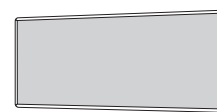

Size H 900mm  
W 2400mm  
Code **PD2490**

Concealed corner fixing

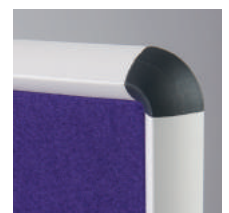

45543/BL/LG



## Shield® Design noticeboards - stocked options



The most popular colour combinations are now available from stock

A premier range of noticeboards with a pronounced contoured frame to create an eye-catching display. Part of the Shield co-ordinated range of products. Noticeboards are available in four stock sizes and can be mounted portrait or landscape with fixings provided. Available either with aluminium frame and covered in blue loop nylon cloth or blue frame with light grey cloth.

See page 18 for full range.

Shield® Design Aluminium Frame / Blue Cloth



Size H 600mm  
W 900mm  
Aluminium Frame / Blue Cloth  
**45532/AL/RB**

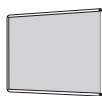

Size H 900mm  
W 1200mm  
Aluminium Frame / Blue Cloth  
**45543/AL/RB**

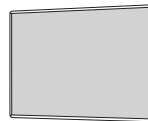

Size H 1200mm  
W 1800mm  
Aluminium Frame / Blue Cloth  
**45564/AL/RB**



Size H 1200mm  
W 2400mm  
Aluminium Frame / Blue Cloth  
**45584/AL/RB**

45564/AL/RB



Shield® Design Blue Frame / Light Grey Cloth



Size H 600mm  
W 900mm  
Blue Frame / Light Grey Cloth  
**45532/BL/LG**

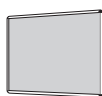

Size H 900mm  
W 1200mm  
Blue Frame / Light Grey Cloth  
**45543/BL/LG**



Size H 1200mm  
W 1800mm  
Blue Frame / Light Grey Cloth  
**45564/BL/LG**



Size H 1200mm  
W 2400mm  
Blue Frame / Light Grey Cloth  
**45584/BL/LG**

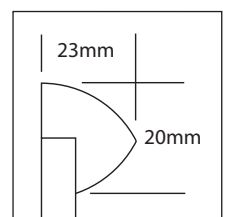

45554/RD/LG



## Shield® Design noticeboards - full range

Aluminium framed noticeboards with a distinctive contemporary styling

This premier range of noticeboards has a raised frame available in satin aluminium or 5 attractive colours. 7 sizes are available in 18 loop nylon cloth colours. Can be mounted portrait or landscape with concealed corner fixings. Part of the Shield® co-ordinated range of products.

### TO ORDER:

Please state the product code followed by the frame colour code and then the code of the cloth colour required.  
EXAMPLE: 1500 x 1200mm with red frame and light grey loop nylon cloth = **45554/RD/LG**

### Frame colours - see page 64



Aluminium Blue Green Red White Black

### Standard loop nylon cloth colours - see page 63



Ink Navy Royal Blueberry Dk Wine Scarlet Yellow Bottle Green Emerald Quince Black Gunmetal Lt Grey Purple Magenta Lilac Orange Cyan Apple



Size H 450mm W 600mm	Size H 600mm W 900mm	Size H 900mm W 1200mm	Size H 1200mm W 1200mm
Code <b>45531</b>	Code <b>45532</b>	Code <b>45543</b>	Code <b>45544</b>



R5544/AL/AG



Size H 1200mm W 1500mm	Size H 1200mm W 1800mm	Size H 1200mm W 2400mm
Code <b>45554</b>	Code <b>45564</b>	Code <b>45584</b>

### Coloured frame



### Aluminium frame

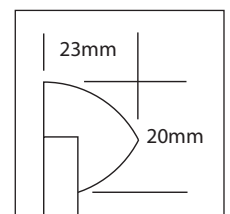

# Shield® Design Resist-a-Flame® class 0 noticeboards

Distinctive fully fire resistant aluminium framed noticeboards with contemporary styling

This premium range of noticeboards also benefit from meeting the latest fire regulations making them ideal for use in any sensitive areas – i.e. corridors, stairwells. This fully assembled product meets BS EN 13501. The raised frame creates an eye catching display. Available in 7 sizes with the frame in satin aluminium or 5 distinctive colours. Boards can be mounted portrait or landscape using concealed corner fixings. 11 cloth colours available. Part of the Shield® co-ordinated range of products.

**TO ORDER:**

Please state the product code followed by the frame colour code and then the code of the cloth colour required.  
EXAMPLE: 1200 x 1500mm with black frame and light blue woven cloth = **R5554/BK/LB**

R5554/BK/LB



Frame colours - see page 64



Resist-a-Flame® woven cloth colours - see page 63



Size H 450mm  
W 600mm  
Code **R5531**



Size H 600mm  
W 900mm  
Code **R5532**

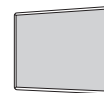

Size H 900mm  
W 1200mm  
Code **R5543**



Size H 1200mm  
W 1200mm  
Code **R5544**

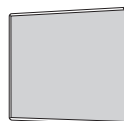

Size H 1200mm  
W 1500mm  
Code **R5554**



Size H 1200mm  
W 1800mm  
Code **R5564**



Size H 1200mm  
W 2400mm  
Code **R5584**

R5543/AL/CR

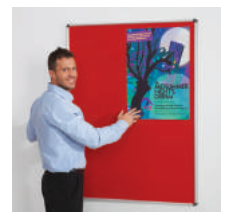

**Standard or Resist-a-Flame?**  
Do you comply with public area building regulations?  
go to: [www.resistaflame.com](http://www.resistaflame.com)

**NEW EUROPEAN REACTION TO FIRE TEST**  
When tested to the relevant European 'Reaction to Fire' tests, this product was classified B-SI, d0 according to BS-EN 13501-1.  
This classification identifies that this product can be used in the same areas as products tested to BS476 Parts 6 and 7 and classified as class 0 according to UK building regulations.

## Shield® Design cork noticeboards



45554/BL/CK

Coloured framed deluxe noticeboard with traditional cork surface

A premier range of noticeboards with a deluxe contoured frame in a choice of 6 attractive finishes. The distinctive styling draws attention to your notices creating an eye catching display. Part of the Shield® co-ordinated range of products. All noticeboards are available in 7 standard sizes and can be mounted portrait or landscape with fixings provided.

**TO ORDER:**

Please state the product code followed by the colour code of the frame required.

EXAMPLE: 1500 x 1200mm with blue frame and cork pinnable surface = **45554/BL/CK**

Frame colours - see page 64



Size H 450mm  
W 600mm  
Code **45531/\*\*/CK**



Size H 600mm  
W 900mm  
Code **45532/\*\*/CK**

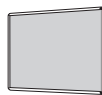

Size H 900mm  
W 1200mm  
Code **45543/\*\*/CK**



Size H 1200mm  
W 1200mm  
Code **45544/\*\*/CK**

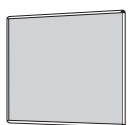

Size H 1200mm  
W 1500mm  
Code **45554/\*\*/CK**

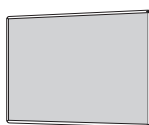

Size H 1200mm  
W 1800mm  
Code **45564/\*\*/CK**

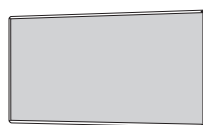

Size H 1200mm  
W 2400mm  
Code **45584/\*\*/CK**

Shield® Design Coloured frame



Shield® Design Aluminium frame

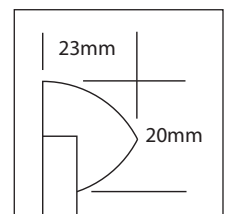

# Shield® Design ThemeBoard noticeboards

Add your Club name, House or Department to these open noticeboards

New range of noticeboards with a 200mm deep drywipe surface header. This enables you to state the Theme or subject of the notices to be displayed by either drywipe pen or applying lettering or customised graphics for a professional finish. This premier range of noticeboards has a raised frame available in satin aluminium or 5 attractive colours. 6 sizes are available in 18 loop nylon cloth colours.

For lockable versions - see page 44

**TO ORDER:**

Please state the product code followed by the frame colour code and then the code of the cloth colour required.  
EXAMPLE: 1200 x 900mm with blue frame and light grey loop nylon cloth = **STH43/BL/LG**

**NOTE:**

Graphic service is available - ask for details



STH43/BL/LG

Frame colours - see page 64



Standard loop nylon cloth colours - see page 63



Size H 900mm W 600mm Code <b>STH32</b>	Size H 1200mm W 900mm Code <b>STH43</b>	Size H 1200mm W 1200mm Code <b>STH44</b>	Size H 1200mm W 1500mm Code <b>STH54</b>	Size H 1200mm W 1800mm Code <b>STH64</b>	Size H 1200mm W 2400mm Code <b>STH84</b>



Shield® Design Coloured frame



Shield® Design Aluminium frame

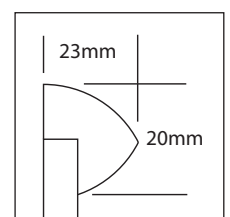

# Noticeboards - Shield® Design



SN94/AL/RB/YL/EG/SC



## Shield® Design multi-banked noticeboards

### Divided noticeboard for separating information

Deluxe coloured frame noticeboard with separated pinnable areas that can be specified with individual colours. Ideal for dividing notices for departments, functions, events and school classes. Choice of 6 frame colours, complimented with a wide range of noticeboard colours.

Also available in Resist-a-Flame® versions, see over.

### TO ORDER:

Please state the product code followed by the frame colour code and then the code of the cloth colour required in the sequence you want it from left to right (if multiple colours required).

EXAMPLE: 900 x 2400mm 4 panel unit with aluminium frame and royal blue, yellow, emerald green and scarlet loop nylon cloth = **SN94/AL/RB/YL/EG/SC**

### Frame colours - see page 64



Aluminium Blue Green Red White Black

### Standard loop nylon cloth colours - see page 63



Ink Navy Royal Blueberry Dk Wine Scarlet Yellow  
Bottle Green Emerald Quince Black Gunmetal Lt Grey  
Purple Magenta Lilac Orange Cyan Apple

Shield® Design  
Aluminium frame

Shield® Design  
Coloured frame

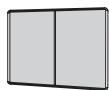

Size H 900mm  
W 1200mm  
No. of Panels 2  
Code **SN92**



Size H 900mm  
W 1800mm  
No. of Panels 3  
Code **SN93**



Size H 900mm  
W 2400mm  
No. of Panels 4  
Code **SN94**

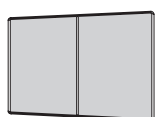

Size H 1200mm  
W 1800mm  
No. of Panels 2  
Code **SN122**

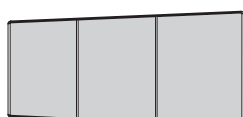

Size H 1200mm  
W 2700mm  
No. of Panels 3  
Code **SN123**

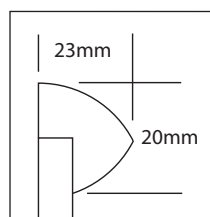





SR93/BL/SL

## Shield® Design Resist-a-Flame® multi-bank

### Divided noticeboard for separating information

Deluxe coloured frame noticeboard with separated pinnable areas that can be specified with individual colours. Ideal for dividing notices for departments, functions, events and school classes. Choice of 6 frame colours, complemented with a wide range of noticeboard colours. Fire resistant cloth and core construction is suitable for mounting in corridors, stairways and entrance areas within public buildings.

For standard loop nylon versions, see previous page.

### TO ORDER:

Please state the product code followed by the frame colour code and then the code of the cloth colour required in the sequence you want it from left to right (if multiple colours required).

EXAMPLE: 900 x 1800mm 3 panel unit with blue frame and silver cloth = **SR93/BL/SL**

### Frame colours - see page 64



### Resist-a-Flame® woven cloth colours - see page 63

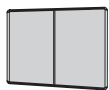

Size H 900mm  
W 1200mm  
No. of Panels 2  
Code **SR92**



Size H 900mm  
W 1800mm  
No. of Panels 3  
Code **SR93**



Size H 900mm  
W 2400mm  
No. of Panels 4  
Code **SR94**

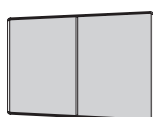

Size H 1200mm  
W 1800mm  
No. of Panels 2  
Code **SR122**



Size H 1200mm  
W 2700mm  
No. of Panels 3  
Code **SR123**

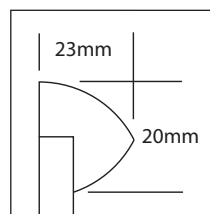

**FIRE RESISTANT RESISTAFLAME**

**Standard or Resist-a-Flame?**  
Do you comply with public area building regulations?  
go to: [www.resistaflame.com](http://www.resistaflame.com)

**NEW EUROPEAN REACTION TO FIRE TEST**  
When tested to the relevant European 'Reaction to Fire' tests, this product was classified B-SI, d0 according to BS-EN 13501-1.  
This classification identifies that this product can be used in the same areas as products tested to BS476 Parts 6 and 7 and classified as class 0 according to UK building regulations.

# Noticeboards - Eco-friendly

EF1512/DB



## Eco-friendly felt noticeboards

Popular range of environmentally friendly noticeboards manufactured to a high quality finish

Frame and pinboard core are constructed from timber industry bi-products and recycled materials. Attractive contoured 35mm wide frame is available in a choice of light oak, mahogany or aluminium effect finishes; complimented by a choice of 5 felt colours. Boards can be mounted portrait or landscape with concealed fixings provided.

### TO ORDER:

Please state the product code followed by the colour code of the cloth required.

EXAMPLE: 1200 x 1500mm in beech with blue felt = **EF1512/BL**



[www.metroplan-ecofriendly.co.uk](http://www.metroplan-ecofriendly.co.uk)



Size H 600mm  
W 900mm  
Light Oak **EF9060**  
Aluminium **EFA9060**  
Mahogany **EFM9060**

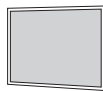

Size H 900mm  
W 1200mm  
Light Oak **EF1290**  
Aluminium **EFA1290**  
Mahogany **EFM1290**



Size H 1200mm  
W 1200mm  
Light Oak **EF1212**  
Aluminium **EFA1212**  
Mahogany **EFM1212**

Felt cloth colours - see page 62

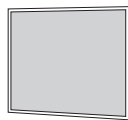

Size H 1200mm  
W 1500mm  
Light Oak **EF1512**  
Aluminium **EFA1512**  
Mahogany **EFM1512**

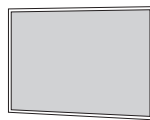

Size H 1200mm  
W 1800mm  
Light Oak **EF1812**  
Aluminium **EFA1812**  
Mahogany **EFM1812**

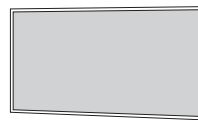

Size H 1200mm  
W 2400mm  
Light Oak **EF2412**  
Aluminium **EFA2412**  
Mahogany **EFM2412**

Light Oak Effect

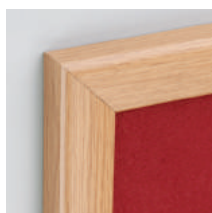

Aluminium Effect



Mahogany Effect



Mahogany EFM1812/LG



Aluminium EFA9060/GR



# Eco-friendly cork noticeboards

A traditional range of environmentally friendly noticeboards using sustainable cork pinnable surface

Frame and board are constructed from timber industry bi-products and sustainable materials. Attractive contoured 35mm wide frame is available in a choice of light oak, mahogany or aluminium effect finishes; complimented by a traditional cork pinnable surface. Boards can be mounted portrait or landscape with concealed fixings provided.



EFM1512/CK



[www.metroplan-ecofriendly.co.uk](http://www.metroplan-ecofriendly.co.uk)



FOR MATCHING WHITEBOARDS - SEE PAGE 74



Size H 600mm  
W 900mm  
Light Oak **EF9060/CK**  
Aluminium **EFA9060/CK**  
Mahogany **EFM9060/CK**

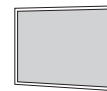

Size H 900mm  
W 1200mm  
Light Oak **EF1290/CK**  
Aluminium **EFA1290/CK**  
Mahogany **EFM1290/CK**

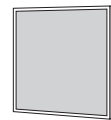

Size H 1200mm  
W 1200mm  
Light Oak **EF1212/CK**  
Aluminium **EFA1212/CK**  
Mahogany **EFM1212/CK**

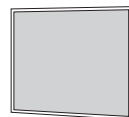

Size H 1200mm  
W 1500mm  
Light Oak **EF1512/CK**  
Aluminium **EFA1512/CK**  
Mahogany **EFM1512/CK**

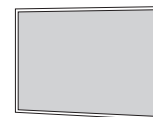

Size H 1200mm  
W 1800mm  
Light Oak **EF1812/CK**  
Aluminium **EFA1812/CK**  
Mahogany **EFM1812/CK**



Size H 1200mm  
W 2400mm  
Light Oak **EF2412/CK**  
Aluminium **EFA2412/CK**  
Mahogany **EFM2412/CK**

Light Oak Effect

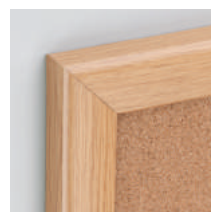

Aluminium Effect



Mahogany Effect

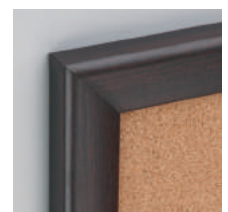

## Eco-premier felt noticeboards

A premier range of eco-friendly noticeboards

Modern bevelled design with a rich grained beech effect or black finish, complimented by a choice of 5 cloth colours. The angled 46mm wide frame tapers away towards the wall, cleverly making the board appear slimmer than it is. Frame and pinboard core are constructed from timber industry bi-products, and recycled materials. All boards can be mounted portrait or landscape, fixings provided.

### TO ORDER:

Please state the product code followed by the colour code of the cloth required.

EXAMPLE: 900 x 1200mm with green felt = **PBF43/GR**



PBF43/GR

Standard felt cloth colours - see page 62



Size H 600mm  
W 900mm  
Beech **PBF32**  
Black **PBL32**

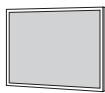

Size H 900mm  
W 1200mm  
Beech **PBF43**  
Black **PBL43**

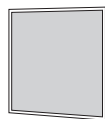

Size H 1200mm  
W 1200mm  
Beech **PBF44**  
Black **PBL44**



[www.metroplan-ecofriendly.co.uk](http://www.metroplan-ecofriendly.co.uk)

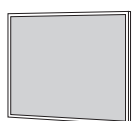

Size H 1200mm  
W 1500mm  
Beech **PBF54**  
Black **PBL54**



Size H 1200mm  
W 1800mm  
Beech **PBF64**  
Black **PBL64**

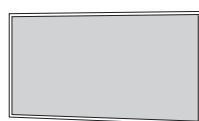

Size H 1200mm  
W 2400mm  
Beech **PBF84**  
Black **PBL84**

PBF32/DB

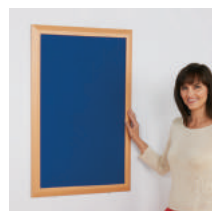

Black Frame

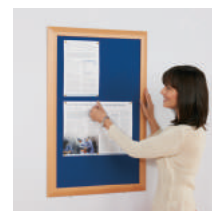

PBF43/CK

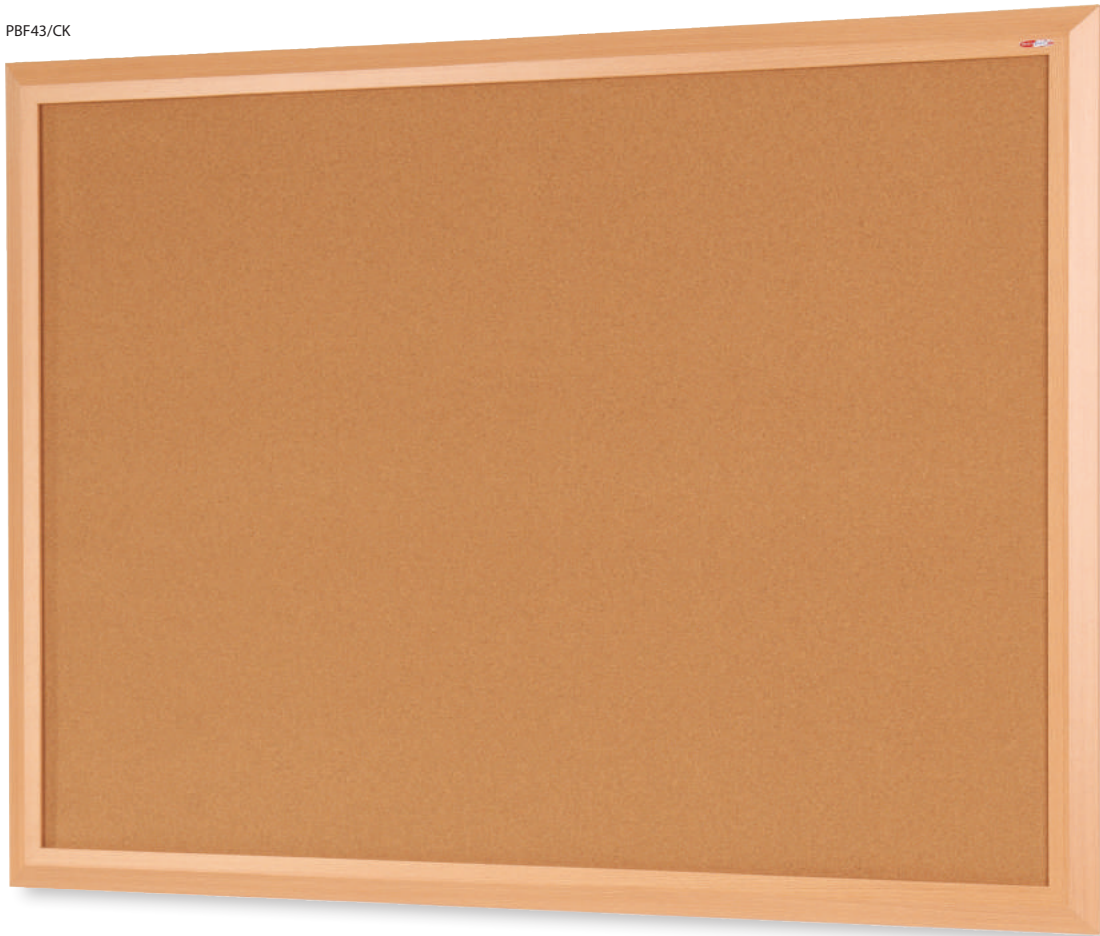

## Eco-premier cork noticeboards

### A premier range of eco-friendly cork noticeboards

Modern bevelled design with a rich grained beech effect or black finish, complimented by traditional cork pinnable surface. The angled 46mm wide frame tapers away towards the wall, cleverly making the board appear slimmer than it is. Frame and board are constructed from timber industry bi-products and sustainable materials. All boards can be mounted portrait or landscape, fixings provided.



[www.metroplan-ecofriendly.co.uk](http://www.metroplan-ecofriendly.co.uk)



Beech Frame



Black Frame



Size H 600mm  
W 900mm  
Beech **PBF32/CK**  
Black **PBL32/CK**

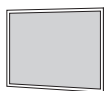

Size H 900mm  
W 1200mm  
Beech **PBF43/CK**  
Black **PBL43/CK**



Size H 1200mm  
W 1200mm  
Beech **PBF44/CK**  
Black **PBL44/CK**

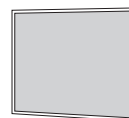

Size H 1200mm  
W 1500mm  
Beech **PBF54/CK**  
Black **PBL54/CK**

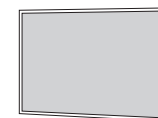

Size H 1200mm  
W 1800mm  
Beech **PBF64/CK**  
Black **PBL64/CK**

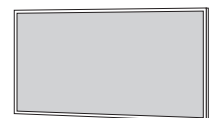

Size H 1200mm  
W 2400mm  
Code **PBF84/CK**  
Black **PBL84/CK**

# Noticeboards - Eco-friendly



CCB32/BL

## Eco-friendly contrast noticeboards

A new range of eco-friendly noticeboards with attractive contrasting colour schemes

Frames are made almost entirely from timber industry bi-products and the pinboard surface from recycled waste newsprint. A choice of 4 colour combinations. Boards can be mounted portrait or landscape with fixings provided.

### TO ORDER:

Please state the product code followed by the colour code of the board required.

EXAMPLE: 900 x 1200mm in Charcoal = **CCB43/CH**

### NOTE:

No fabric - for use with pins only



[www.metroplan-ecofriendly.co.uk](http://www.metroplan-ecofriendly.co.uk)



Blue - BL

Red - RD

Green - GR

Charcoal - CH



**Pinnable colourboard colours** - see page 62



Size H 600mm  
W 900mm  
Code **CCB32**

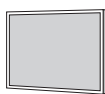

Size H 900mm  
W 1200mm  
Code **CCB43**

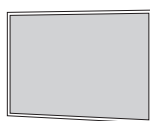

Size H 1200mm  
W 1800mm  
Code **CCB64**



Size H 1200mm  
W 2400mm  
Code **CCB84**

CCB43/CH



## Eco-friendly light oak recycled noticeboards

OCB43/LC

A range of noticeboards made from recycled waste newsprint with attractive light oak effect frame

35mm frame constructed almost entirely from timber industry bi-products and the pinboard surface from recycled waste newsprint. 6 board colours. Mount landscape or portrait. Fixings provided.

**TO ORDER:**

Please state the product code followed by the colour code of the board required.

EXAMPLE: 900 x 1200mm in Lilac = **OCB43/LC**

**NOTE:**

No fabric - for use with pins only



[www.metroplan-ecofriendly.co.uk](http://www.metroplan-ecofriendly.co.uk)



**Pinnable colourboard colours** - see page 62



OCB43/BL



Size H 600mm  
W 900mm  
Code **OCB32**

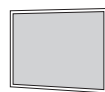

Size H 900mm  
W 1200mm  
Code **OCB43**

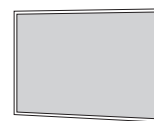

Size H 1200mm  
W 1800mm  
Code **OCB64**

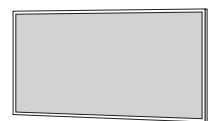

Size H 1200mm  
W 2400mm  
Code **OCB84**

# Noticeboards - Eco-friendly



## Eco-friendly dual felt drywipe noticeboards

### Combination pinnable notice and drywipe board

Useful dual purpose noticeboard. Frame and pinboard core are constructed from timber industry bi-products, and recycled materials. Attractive contoured 35mm wide frame is finished in light oak effect, with half whiteboard complimented by a choice of five felt colours for the noticeboard surface.

#### TO ORDER:

Please state the product code followed by the colour code of the cloth required.

EXAMPLE: 900 x 1200mm in green = **ED1290/GR**



ED1290/GR



Size H 600mm  
W 900mm  
Felt **ED9060**

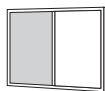

Size H 900mm  
W 1200mm  
Felt **ED1290**

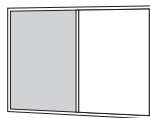

Size H 1200mm  
W 1800mm  
Felt **ED1812**

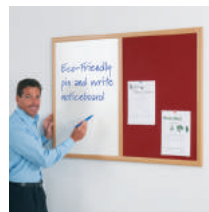

#### Felt cloth colours - see page 62



Blue



Burgundy



Red



Green



Grey

## Eco-friendly dual cork drywipe noticeboards



### Combination pinnable cork notice and drywipe board

Useful dual purpose noticeboard. Frame and pinboard are constructed from timber industry bi-products, and sustainable materials. Attractive contoured 35mm wide frame is finished in light oak effect, with half whiteboard complimented by traditional cork for the noticeboard surface.



ED1290/CK



Size H 600mm  
W 900mm  
Cork **ED9060/CK**

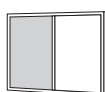

Size H 900mm  
W 1200mm  
Cork **ED1290/CK**

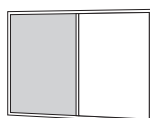

Size H 1200mm  
W 1800mm  
Cork **ED1812/CK**





## Eco-friendly tamperproof noticeboards

This range of Eco-friendly covered noticeboards has a lockable light oak effect frame

Frame and pinboard core are constructed from timber industry bi-products and recycled materials. Attractive 35mm wide contoured frame in a light oak effect finish, available in a selection of 5 felt colours or traditional cork. Left, right or top hinge mounting, create larger unit by mounting one left hinge next to a right hinge unit. All units have 2 locks with matching keys

### TO ORDER:

Please state the product code followed by the colour code of the cloth required.

EXAMPLE: 1200 x 900mm in blue = **EFT1290/DB**

Felt cloth colours - see page 62

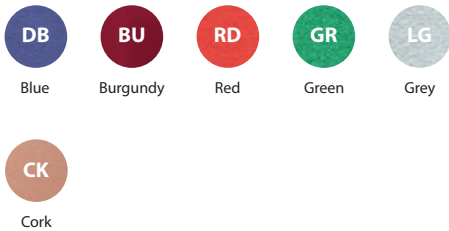

EFT1290/DB



Size H 900mm  
W 600mm  
Felt **EFT9060**

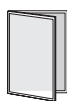

Size H 1200mm  
W 900mm  
Felt **EFT1290**



Size H 900mm  
W 600mm  
Cork **EFT9060/CK**



Size H 1200mm  
W 900mm  
Cork **EFT1290/CK**

EFT1290/DB

EFT9060/CK

### Mounting options

Hinged left    Hinged right    Top hinged    Side by side

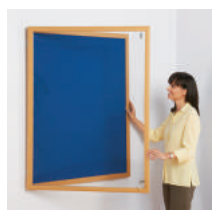
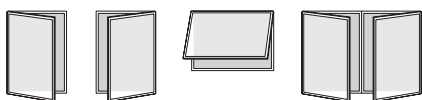

# Noticeboards - Aluminium Framed Lockable



## Felt tamperproof noticeboards

Our most popular covered noticeboards with lockable doors

These tamperproof noticeboards offer an effective way of protecting notices from casual interference in busy public areas. 7 popular sizes available with a choice of colour options. Locks with matching keys per door. Single door versions can be mounted portrait or landscape, with hinge to side, base or top; but do not include support stays.

### TO ORDER:

Please state the product code followed by the colour code of the cloth required.

EXAMPLE: 1200 x 900mm in blue felt = **TP1290/DB**



Size H 600mm  
W 450mm  
Code **TP6045**



Size H 900mm  
W 600mm  
Code **TP9060**



Size H 900mm  
W 900mm  
Code **TP9090**



Size H 1200mm  
W 900mm  
Code **TP1290**

Standard felt cloth colours - see page 62



Blue



Burgundy



Red



Green



Grey



Light Blue

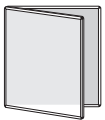

Size H 1200mm  
W 1200mm  
Code **TP1212**

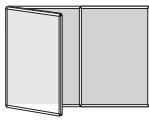

Size H 1200mm  
W 1800mm  
Code **TP1812**

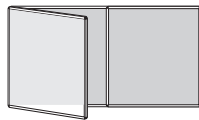

Size H 1200mm  
W 2400mm  
Code **TP2412**

Concealed corner fixings



TP1290/GR



TP1812/LG



TP1812/LG





PST1890/PU

## ColourPlus tamperproof noticeboards

Stunning range of lockable noticeboards available in a choice of 6 modern cloth colours

Made in UK, to the highest specifications with 2 matching locks per door, full length glazing bars and quality hinges for extra stability. ColourPlus fabrics accept pins. Supplied complete with fixings. Single door versions can be mounted with hinge to side, base or top but do not include support stays.

For Shield® Design white frame version - see page 39

ColourPlus fabric colours - see page 62

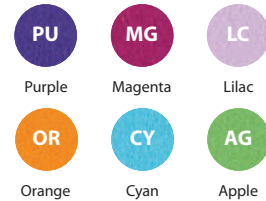

## ColourPlus

### TO ORDER:

Please state the product code followed by the colour code of the board required.

EXAMPLE: 900 x 1800mm in Purple = **PST1890/PU**

PST9060/CY

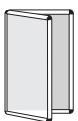

Size H 900mm  
W 600mm  
Code **PST9060**



Size H 900mm  
W 900mm  
Code **PST9090**

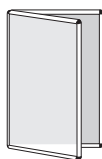

Size H 1200mm  
W 900mm  
Code **PST1290**

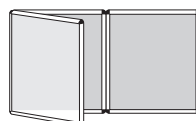

Size H 900mm  
W 1800mm  
Code **PST1890**

# Noticeboards - Aluminium Framed Lockable



TF1290/CO

## Tamperproof noticeboards with fire retardant cloth

Fabric tested to BS5867 Part 2 2008; Type B

These aluminium framed noticeboards use the same attractive display stitchbond fabric as our Resist-a-Flame® range but with a standard fibreboard core. The fabric is individually tested to BS5867 Part 2 2008; Type B curtains, drapes and blinds. These boards are for use in non-sensitive areas. For all other areas i.e. fire escapes, stairwells, lobbies etc see Resist-a-Flame® on the opposite page. 2 locks per door with matching keys. Single door versions can be mounted portrait or landscape.

TO ORDER:

Please state the product code followed by the colour code of the cloth required.

EXAMPLE: 900 x 1200mm in conifer cloth = **TF1290/CO**



Size H 900mm  
W 600mm  
Code **TF9060**



Size H 900mm  
W 900mm  
Code **TF9090**



Size H 1200mm  
W 900mm  
Code **TF1290**

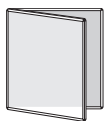

Size H 1200mm  
W 1200mm  
Code **TF1212**

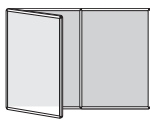

Size H 1200mm  
W 1800mm  
Code **TF1812**

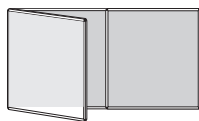

Size H 1200mm  
W 2400mm  
Code **TF2412**

Woven cloth colours - see page 63



TF1290/CO

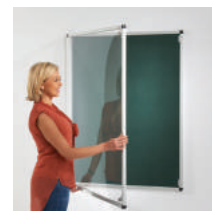

# Aluminium Framed Lockable - Noticeboards



45341/CR

## Resist-a-Flame® tamperproof noticeboards

Resist-a-Flame® woven cloth colours - see page 63  
Stocked range



Dk Blue    Crimson    Conifer    Silver    Plum

Extended range - made to order  
Please allow for a slightly longer delivery time



Lt Blue    Grey Green    Ebony    Charcoal    Caspian    Mustard

Fire resistant covered noticeboards with side hinged lockable doors

Market leading range of fire resistant covered noticeboards fully constructed and tested to meet the latest building and fire regulations. Ideal for use in public buildings and industrial applications. Available in a choice of 11 woven cloth colours. Cloth and pinboard core tested to BS EN 13501 and classified as B-S1, d0. Clear covers tested to BS 476 part 7 class 1Y. Single door versions can be mounted portrait or landscape, with hinge to side, base or top; but do not include support stays.

For top hinged tamperproofs, see page 36.

TO ORDER:

Please state the product code followed by the colour code of the cloth required.

EXAMPLE: 1200 x 1800mm in crimson cloth = **45341/CR**



[www.resistafire.com](http://www.resistafire.com)

45321/DB



45341/CR



Size    H 900mm  
          W 600mm  
Code    **45301**



Size    H 900mm  
          W 900mm  
Code    **45311**



Size    H 1200mm  
          W 900mm  
Code    **45321**

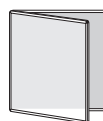

Size    H 1200mm  
          W 1200mm  
Code    **45331**

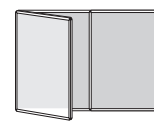

Size    H 1200mm  
          W 1800mm  
Code    **45341**

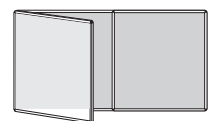

Size    H 1200mm  
          W 2400mm  
Code    **45351**

# Noticeboards - Aluminium Framed Lockable



## Resist-a-Flame® corridor tamperproof noticeboards

### Top hinged lockable noticeboards with door supports

The ultimate choice for use in corridor applications. The door opens upwards and is kept in place with support stays, offering increased safety whilst changing notices. Made in the UK to the highest specification and meet guidelines set in the BB100 document for safeguarding against fire in schools. 2 locks per door with matching keys. Available in a choice of 11 woven cloth colours. Cloth and pinboard core tested to BS EN 13501. Clear covers tested to BS 476 part 7 class 1Y.

### TO ORDER:

Please state the product code followed by the colour code of the cloth required.

EXAMPLE: 1200 x 1200mm

in blue woven cloth = **47304/DB**



Size H 600mm  
W 900mm  
Code **47301**



Size H 900mm  
W 900mm  
Code **47302**

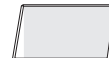

Size H 900mm  
W 1200mm  
Code **47303**



Size H 1200mm  
W 900mm  
Code **47305**



Size H 1200mm  
W 1200mm  
Code **47304**

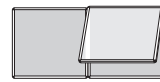

Size H 900mm  
W 1800mm  
Code **4536\***

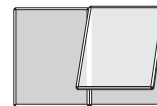

Size H 1200mm  
W 1800mm  
Code **4538\***

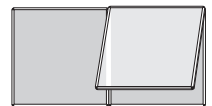

Size H 1200mm  
W 2400mm  
Code **4537\***

\* Double door top hinged units are delivered in two parts for ease of installation.

### Resist-a-Flame® woven cloth colours - see page 63

#### Stocked range



Dk Blue    Crimson    Conifer    Silver    Plum

### Extended range - made to order

Please allow for a slightly longer delivery time



Lt Blue    Grey Green    Ebony    Charcoal    Caspian    Mustard



**Standard or Resist-a-Flame?**  
Do you comply with public area building regulations?  
go to: [www.resistaflame.com](http://www.resistaflame.com)

**NEW EUROPEAN REACTION TO FIRE TEST**  
When tested to the relevant European 'Reaction to Fire' tests, this product was classified B-S1, d0 according to BS-EN 13501-1.  
This classification identifies that this product can be used in the same areas as products tested to BS476 Parts 6 and 7 and classified as class 0 according to UK building regulations.

4537/DB



Built in support stays...

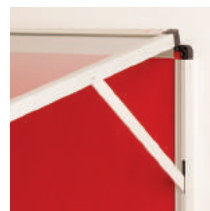

... ideal for corridor use



## Tamperproof recycled noticeboards

Lockable covered noticeboards with the pinboard made from recycled waste newsprint

Each door has 2 matching locks. Single door versions mount portrait or landscape. No support stays.

### TO ORDER:

Please state the product code followed by the colour code of the cloth required.

EXAMPLE: 1200 x 1800mm in Red = **TPC64/RD**

### NOTE:

No fabric - for use with pins only



TPC64/RD



[www.metroplan-ecofriendly.co.uk](http://www.metroplan-ecofriendly.co.uk)



Size H 900mm  
W 600mm  
Code **TPC32**



Size H 1200mm  
W 900mm  
Code **TPC43**



Size H 1200mm  
W 1200mm  
Code **TPC44**

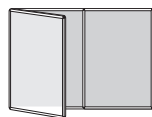

Size H 1200mm  
W 1800mm  
Code **TPC64**

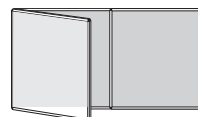

Size H 1200mm  
W 2400mm  
Code **TPC84**

### Pinnable colourboard colours - see page 62



FOR UNGLAZED VERSIONS - SEE PAGE 12



TPC64/RD



# Noticeboards - Aluminium Framed Lockable



TPH1212/RD

## ThemeBoard tamperproof noticeboards

Add your Club name, House or Department to these lockable covered noticeboards

New range of lockable noticeboards with a 200mm deep drywipe surface header. This enables you to state the Theme or subject of the notices to be displayed by either drywipe pen or applying lettering or customised graphics for a professional finish. This tamperproof version has the added advantage of lockable doors to protect the information on display from casual interference. Quality construction with 2 matching locks per door, full length glazing bars and quality hinges for extra stability in design. Supplied complete with fixings. Choose from standard felt covered board for use with pins or Velcro® or traditional pinnable cork

### TO ORDER:

Please state the product code followed by the colour code of the board required.

EXAMPLE: Standard Felt 1200 x 1200mm in Red = **TPH1212/RD**

### NOTE:

Graphic service is available - ask for details

Felt cloth colours - see page 62

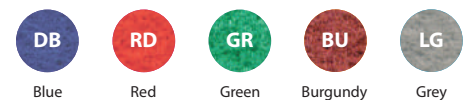

Traditional cork



Size H 900mm  
W 600mm  
Felt Cloth or Cork  
**TPH9060**



Size H 900mm  
W 900mm  
Felt Cloth or Cork  
**TPH9090**

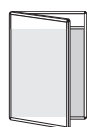

Size H 1200mm  
W 900mm  
Felt Cloth or Cork  
**TPH1290**

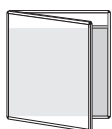

Size H 1200mm  
W 1200mm  
Felt Cloth or Cork  
**TPH1212**

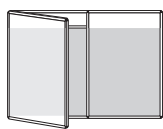

Size H 1200mm  
W 1800mm  
Felt Cloth or Cork  
**TPH1812**

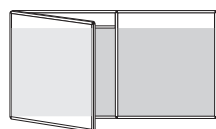

Size H 1200mm  
W 2400mm  
Felt Cloth or Cork  
**TPH2412**

TPH1212/RD

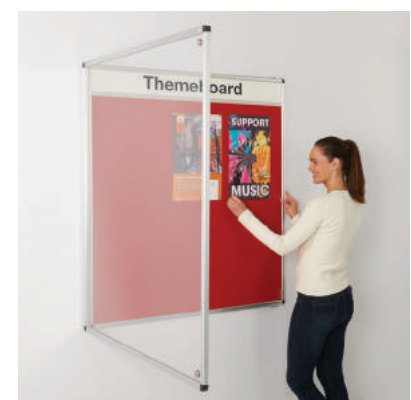



## Shield® Design ColourPlus tamperproof noticeboards

ColourPlus range features vibrant and contemporary colourways

A stunning range of lockable noticeboards in a choice of 6 modern cloth colours framed in the contemporary white Shield® trim. Made to the highest specifications with 2 matching locks per door, full length glazing bars and quality hinges for extra stability. ColourPlus fabrics for use with pins. Supplied complete with fixings. Made in the UK.

For open versions see page 16

### TO ORDER:

Please state the product code followed by the colour code of the board required.

EXAMPLE: Shield® single door 1200 x 900mm with white trim in Apple Green = **PDT1290/AG**



PDT1290/AG

### ColourPlus fabric colours - see page 62

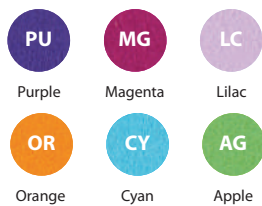

PDT9090/MG



Size H 900mm  
W 600mm  
Code **PDT9060**

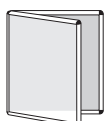

Size H 900mm  
W 900mm  
Code **PDT9090**



Size H 1200mm  
W 900mm  
Code **PDT1290**

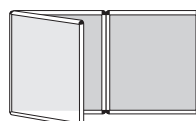

Size H 900mm  
W 1800mm  
Code **PDT1890**



# Noticeboards - Shield® Design Lockable

STP9060/AL/RB



## Shield® Design tamperproof noticeboards stock options

A deluxe lockable noticeboard made in the UK to the highest specifications

This contemporary styled showcase is available in 4 standard sizes from stock in 2 most popular colour ranges. Each door has 2 locks with matching keys. For full range see opposite page.



Aluminium Frame / Blue Cloth



Size H 900mm  
W 600mm  
Aluminium Frame / Blue Cloth  
**STP9060/AL/RB**



Size H 1200mm  
W 900mm  
Aluminium Frame / Blue Cloth  
**STP1290/AL/RB**

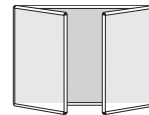

Size H 1200mm  
W 1800mm  
Aluminium Frame / Blue Cloth  
**STP1812/AL/RB**

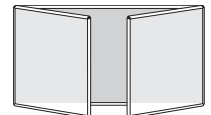

Size H 1200mm  
W 2400mm  
Aluminium Frame / Blue Cloth  
**STP2412/AL/RB**

Blue Frame / Light Grey Cloth



Size H 900mm  
W 600mm  
Blue Frame / Light Grey Cloth  
**STP9060/BL/LG**



Size H 1200mm  
W 900mm  
Blue Frame / Light Grey Cloth  
**STP1290/BL/LG**

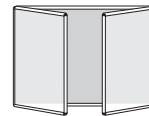

Size H 1200mm  
W 1800mm  
Blue Frame / Light Grey Cloth  
**STP1812/BL/LG**

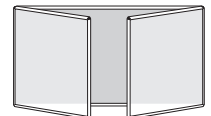

Size H 1200mm  
W 2400mm  
Blue Frame / Light Grey Cloth  
**STP2412/BL/LG**

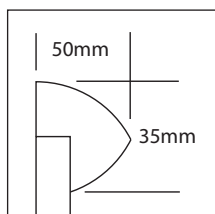

Blue frame with grey infill



STP9060/AL/RB



STP1812/AL/RB



## Shield® Design tamperproof noticeboards full range

### Contemporary framed premium lockable noticeboards

Contemporary styling, and a wide range of frame and cloth colours for this deluxe covered noticeboard. Available in a range of 6 sizes and 6 frame colour options combined with a choice of 18 loop nylon colours. Heavy duty design and construction using quality hinges, locks, 3mm thick PET covers and full length glazing bars. Single door versions can be mounted portrait or landscape, with hinge to side, base or top; but does not include support stays. For flame resistant and top hinged versions please see pages 42-43.

#### TO ORDER:

Please state the product code followed by the frame colour code and then the code of the cloth colour required.

EXAMPLE: 1200 x 1200mm with red frame and light grey loop nylon cloth = **STP1212/RD/LG**



#### Frame colours - see page 64



#### Standard loop nylon cloth colours - see page 63



STP1212/RD/LG



Size H 900mm  
W 600mm  
Code **STP9060**



Size H 900mm  
W 900mm  
Code **STP9090**

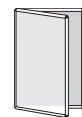

Size H 1200mm  
W 900mm  
Code **STP1290**

STP1212/RD/LG

Coloured frame

Aluminium frame

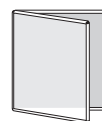
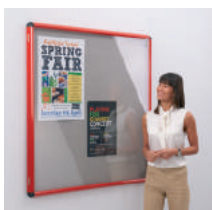

Size H 1200mm  
W 1200mm  
Code **STP1212**

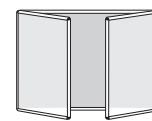

Size H 1200mm  
W 1800mm  
Code **STP1812**

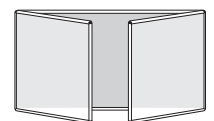

Size H 1200mm  
W 2400mm  
Code **STP2412**

# Noticeboards - Shield® Design Lockable

57305/AL/CR



## Shield® Design Resist-a-Flame® corridor tamperproof noticeboards

Top hinged lockable deluxe fire resistant noticeboard with door stays

These are recommended for use in corridors or other high risk areas. Doors hinge upwards with support stays offering increased ease when changing notices. Cloth and pinboard core tested to BS EN 13501. Clear covers tested to BS 476 part 7 class 1Y. Made in the UK to the highest specification and meet guidelines set in the BB100 document for safeguarding against fire in schools. Available in 6 frame colours and 11 cloth colours each door has 2 matching locks.

### TO ORDER:

Please state the product code followed by the frame colour code and then the code of the cloth colour required. EXAMPLE: 1200 x 1200mm with aluminium frame and crimson woven cloth = **57305/AL/CR**

### Frame colours - see page 64



Aluminium Blue Green Red White Black

### Resist-a-Flame® woven cloth colours - see page 63



Lt Blue Grey Green Ebony Charcoal Caspian Mustard



Coloured frame



Aluminium frame



Size H 600mm  
W 900mm  
Code **57301**



Size H 900mm  
W 900mm  
Code **57302**



Size H 900mm  
W 1200mm  
Code **57303**



Size H 1200mm  
W 900mm  
Code **57304**

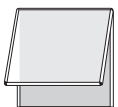

Size H 1200mm  
W 1200mm  
Code **57305**



Size H 900mm  
W 1800mm  
Code **5536\***

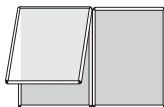

Size H 1200mm  
W 1800mm  
Code **5538\***

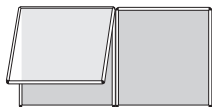

Size H 1200mm  
W 2400mm  
Code **5537\***

\* Double door top hinged units are delivered in two parts for ease of installation.

**Standard or Resist-a-Flame?**  
Do you comply with public area building regulations?  
go to: [www.resistaflame.com](http://www.resistaflame.com)

**NEW EUROPEAN REACTION TO FIRE TEST**  
When tested to the relevant European 'Reaction to Fire' tests, this product was classified B-SI, d0 according to BS-EN 13501-1.  
This classification identifies that this product can be used in the same areas as products tested to BS476 Parts 6 and 7 and classified as class 0 according to UK building regulations.



55341/AL/DB



## Shield® Design Resist-a-Flame® tamperproof noticeboards

Contemporary heavy duty flame resistant lockable noticeboards

Cloth and pinboard core have been tested to BS EN 13501, clear covers tested to BS 476 part 7 class 1Y. Contemporary styling, and a wide range of frame and cloth colours for this deluxe covered noticeboard. Available in range of 6 sizes of flame resistant noticeboards. Single door versions can be mounted portrait or landscape, with hinge to side, base or top; but does not include support stays.

For top hinged versions please see page 42.

### TO ORDER:

Please state the product code followed by the frame colour code and then the code of the cloth colour required.  
EXAMPLE: 1200 x 1800mm with aluminium frame and dark blue cloth = **55341/AL/DB**

Frame colours - see page 64



Resist-a-Flame® woven cloth colours - see page 63



Coloured frame



Aluminium frame



[www.resistaflame.com](http://www.resistaflame.com)



Size H 900mm  
W 600mm  
Code **55301**



Size H 900mm  
W 900mm  
Code **55311**



Size H 1200mm  
W 900mm  
Code **55321**

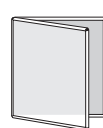

Size H 1200mm  
W 1200mm  
Code **55331**

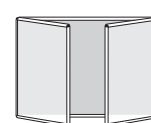

Size H 1200mm  
W 1800mm  
Code **55341**

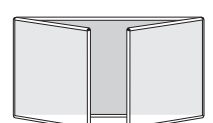

Size H 1200mm  
W 2400mm  
Code **55351**



# Noticeboards - Shield® Design Lockable



STPH43/WH/RB

## Shield® Design ThemeBoard tamperproof noticeboards

Add your Club name, House or Department to these contemporary framed premium lockable noticeboards

This new range of lockable noticeboards has a 200mm deep drywipe surface header. This enables you to state the Theme or subject of the notices to be displayed by either drywipe pen or applying lettering or customised graphics for a professional finish. Contemporary styling, and a wide range of frame and cloth colours for this deluxe covered noticeboard. Lockable doors protect the information on display from casual interference. Available in a range of 6 sizes and 6 frame colour options combined with a choice of 18 loop nylon colours. Single door versions can be mounted portrait or landscape, with hinge to side, base or top; but does not include support stays.

### TO ORDER:

Please state the product code followed by the frame colour code and then the code of the cloth colour required.

EXAMPLE: 1200 x 900mm with white frame and royal blue loop nylon cloth = **STPH43/WH/RB**

### NOTE:

Graphic service is available - ask for details

### Frame colours - see page 64



Aluminium Blue Green Red White Black

### Standard loop nylon cloth colours - see page 63



Ink Navy Royal Blueberry Dk Wine Scarlet Yellow

Bottle Green Emerald Quince Black Gunmetal Lt Grey

Purple Magenta Lilac Orange Cyan Apple



Size H 900mm  
W 600mm  
Code **STP32**



Size H 900mm  
W 900mm  
Code **STPH33**



Size H 1200mm  
W 900mm  
Code **STPH43**

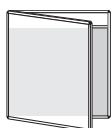

Size H 1200mm  
W 1200mm  
Code **STPH44**

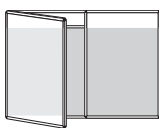

Size H 1200mm  
W 1800mm  
Code **STPH64**

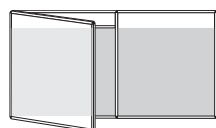

Size H 1200mm  
W 2400mm  
Code **STPH84**

Coloured frame in white



STPH43/WH/RB

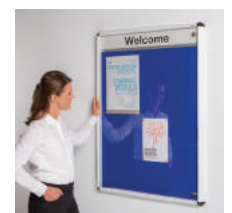
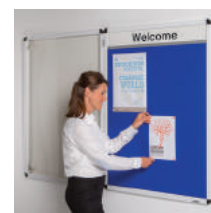

# Shield® Showcase with lift off cover

Contemporary locking showcase with lift off cover

Shield® coloured frame options create a stylish covered noticeboard at an affordable price. 4 size options to accommodate 2, 4, 9 or 12 x A4 sheets of paper. Choice of 5 frame colours complimented by a wide range of loop nylon cloth colours.

### Resist-a-Flame®

Fire resistant version. Banked versions are also available that are designed for use in public buildings and industrial applications, see pages 46-47. Cloth and pinboard core tested to BS EN 13501. Clear covers tested to BS 476 part 7 class 1Y. Wide range of woven cloth colours.

### TO ORDER:

Please state the product code followed by the frame colour code and then the code of the cloth colour required.  
EXAMPLE: 1037 x 720mm with blue frame and light grey nylon cloth = **SSM1/BL/LG**

SSM1/BL/LG



Frame colours - see page 64



Aluminium Blue Green Red White

Standard loop nylon cloth colours - see page 63



Ink Navy Royal Blueberry Dk Wine Scarlet Yellow  
Bottle Green Emerald Quince Black Gunmetal Lt Grey  
Purple Magenta Lilac Orange Cyan Apple

Resist-a-Flame® woven cloth colours - see page 63



Lt Blue Grey Green Ebony Charcoal Caspian Mustard



www.resistaflame.com



Size H 446mm  
W 491mm  
Takes 2 x A4  
Standard **SSX1**  
Resist-a-Flame® **SSRX1**



Size H 735mm  
W 491mm  
Takes 4 x A4  
Standard **SSS1**  
Resist-a-Flame® **SSRS1**



Size H 1037mm  
W 720mm  
Takes 9 x A4  
Standard **SSM1**  
Resist-a-Flame® **SSRM1**

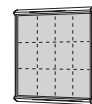

Size H 1037mm  
W 936mm  
Takes 12 x A4  
Standard **SSL1**  
Resist-a-Flame® **SSRL1**

SSL1/RD/BK

Coloured frame

Aluminium frame



FOR MATCHING SHOWCASE ON STANDS - SEE PAGE 56

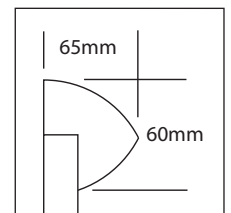
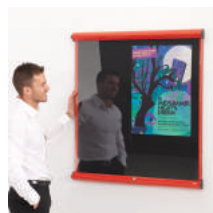

# Noticeboards - Shield® Showcase

SSS4/AL/EG/YL/RB/SC



## Shield® multi-bank showcase with lift off covers

Lockable noticeboard divided for separate information

Multi-panel covered noticeboard. Each panel is supplied with its own lockable door (matching keys) and can be individually coloured. Available in three panel sizes, to accommodate 4, 9 or 12 sheets of A4 paper per panel; and banked in 2, 3 or 4 panels. Lockable covers lift off to easily change the material on display. Supplied fully assembled and ready to mount.

TO ORDER:

Please state the product code followed by the frame colour code and then the code of the cloth colour required in order from left to right (if multiple colours required).

EXAMPLE: 735 x 2000mm 4 panel unit with aluminium frame and emerald green, yellow, royal and scarlet loop nylon cloth = **SSS4/AL/EG/YL/RB/SC**



Size H 735mm  
W 994mm  
Takes 8 x A4  
Code **SSS2**

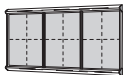

Size H 735mm  
W 1497mm  
Takes 12 x A4  
Code **SSS3**

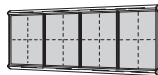

Size H 735mm  
W 2000mm  
Takes 16 x A4  
Code **SSS4**

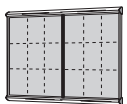

Size H 1037mm  
W 1446mm  
Takes 18 x A4  
Code **SSM2**

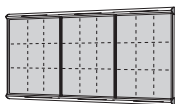

Size H 1037mm  
W 2172mm  
Takes 27 x A4  
Code **SSM3**

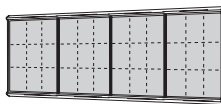

Size H 1037mm  
W 2898mm  
Takes 36 x A4  
Code **SSM4**

Frame colours - see page 64



Standard loop nylon cloth colours - see page 63

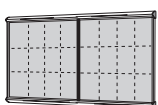

Size H 1037mm  
W 1881mm  
Takes 24 x A4  
Code **SSL2**

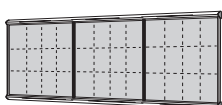

Size H 1037mm  
W 2822mm  
Takes 36 x A4  
Code **SSL3**

SSM3/BL/LG





SSRM3/BL/SL



## Shield® Resist-a-Flame® multi-bank showcase with lift off covers

### Flame retardant multiple panel lockable noticeboards

Fully constructed and tested to meet the latest building and fire regulations. Ideal for use in public buildings and industrial applications. Cloth and pinboard core tested to BS EN 13501. Clear covers tested to BS 476 part 7 class 1Y. Available in a choice of 5 frame colours, complimented by eleven woven cloth colours. Each panel is supplied with its own lockable door that lift off for changing the material on display. Matching keys. Each panel can be individually coloured. Available in 3 panel sizes, to accommodate 4, 9 or 12 sheets of A4 paper per panel; and banked in 2, 3 or 4 panels. Supplied fully assembled and ready to mount.

### TO ORDER:

Please state the product code followed by the frame colour code and then the code of the cloth colour required in order from left to right (if multiple colours required).  
EXAMPLE: 1037 x 2172mm 3 panel unit with blue frame and silver woven cloth = **SSRM3/BL/SL**

#### Frame colours - see page 64



#### Resist-a-Flame® woven cloth colours - see page 63



Size H 735mm  
W 994mm  
Takes 8 x A4  
Code **SSRS2**

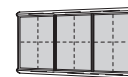

Size H 735mm  
W 1497mm  
Takes 12 x A4  
Code **SSRS3**



Size H 735mm  
W 2000mm  
Takes 16 x A4  
Code **SSRS4**

#### Coloured frame

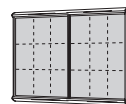

Size H 1037mm  
W 1446mm  
Takes 18 x A4  
Code **SSRM2**

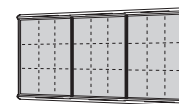

Size H 1037mm  
W 2172mm  
Takes 27 x A4  
Code **SSRM3**

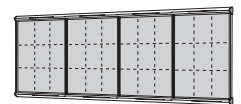

Size H 1037mm  
W 2898mm  
Takes 36 x A4  
Code **SSRM4**

#### Aluminium frame

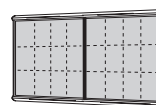

Size H 1037mm  
W 1881mm  
Takes 24 x A4  
Code **SSRL2**

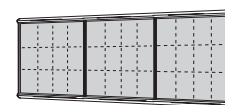

Size H 1037mm  
W 2822mm  
Takes 36 x A4  
Code **SSRL3**



**FIRE RESISTANT**

## RESISTAFLAME

**Standard or Resist-a-Flame?**

Do you comply with public area building regulations?  
go to: [www.resistaflame.com](http://www.resistaflame.com)

**NEW EUROPEAN REACTION TO FIRE TEST**

When tested to the relevant European 'Reaction to Fire' tests, this product was classified B-SI, d0 according to BS-EN 13501-1.

This classification identifies that this product can be used in the same areas as products tested to BS476 Parts 6 and 7 and classified as class 0 according to UK building regulations.



SDS15/AL/SC

## Shield® showcase with sliding glass doors

Sliding toughened glass doors for increased safety

Shield® showcase with sliding glass doors that eliminates a hinged door protruding into a corridor. Available in four sizes, each designed to accommodate a 8, 12, 15 or 18 A4 sheets of paper. This interior showcase has toughened safety glass 6mm thick and kite marked for added peace of mind. Available in any combination of 5 frame colours with a wide range of loop nylon cloth options. For interior use only. Also available in fire resistant versions, please see opposite page.

### TO ORDER:

Please state the product code followed by the frame colour code and then the code of the cloth colour required.  
EXAMPLE: 1050 x 1182mm with aluminium frame and scarlet loop nylon cloth = **SDS15/AL/SC**

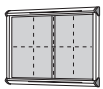

Size H 750mm  
W 967mm  
Takes 8 x A4  
Code **SDS8**

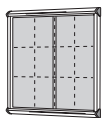

Size H 1050mm  
W 1012mm  
Takes 12 x A4  
Code **SDS12**

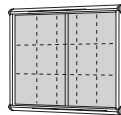

Size H 1050mm  
W 1182mm  
Takes 15 x A4  
Code **SDS15**

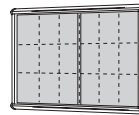

Size H 1050mm  
W 1397mm  
Takes 18 x A4  
Code **SDS18**

Frame colours - see page 64



Standard loop nylon cloth colours - see page 63

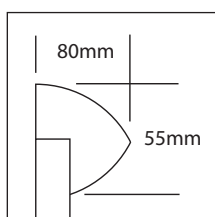

Coloured frame



Aluminium frame



# Shield® Resist-a-Flame® showcase with sliding glass doors

SDFS15/AL/LB

Pinboard core and cloth tested to meet current fire regulations

Ideal for use in public buildings and industrial applications. Cloth and pinboard core tested to BS EN 13501. Sliding glass doors eliminate hinged doors protruding into a corridor. This interior showcase has toughened safety glass 6mm thick and kite marked for added peace of mind. Available in four sizes, each designed to accommodate a given number of A4 sheets of paper. Available in any combination of 5 frame colours together with a range of 11 woven cloth options.

**TO ORDER:**

Please state the product code followed by the frame colour code and then the code of the cloth colour required.

EXAMPLE: 1050 x 1182mm with aluminium frame and light blue Resist-a-Flame® woven cloth = **SDFS15/AL/LB**



Frame colours - see page 64



Resist-a-Flame® woven cloth colours - see page 63

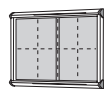

Size H 750mm  
W 967mm  
Takes 8 x A4  
Code **SDFS8**

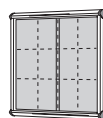

Size H 1050mm  
W 1012mm  
Takes 12 x A4  
Code **SDFS12**

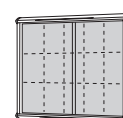

Size H 1050mm  
W 1182mm  
Takes 15 x A4  
Code **SDFS15**

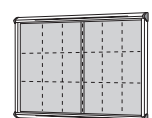

Size H 1050mm  
W 1397mm  
Takes 18 x A4  
Code **SDFS18**

Coloured frame



Aluminium frame

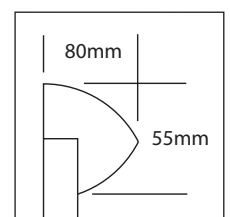

**FIRE RESISTAFLAME**

**Standard or Resist-a-Flame?**  
Do you comply with public area building regulations?  
go to: [www.resistaflame.com](http://www.resistaflame.com)

**NEW EUROPEAN REACTION TO FIRE TEST**  
When tested to the relevant European 'Reaction to Fire' tests, this product was classified B-S1, d0 according to BS-EN 13501-1.  
This classification identifies that this product can be used in the same areas as products tested to BS476 Parts 6 and 7 and classified as class 0 according to UK building regulations.



SCRP12/WH/CY

## Shield® showcase with top hinged doors

Deluxe range of covered noticeboards with top hinged lockable cover

High quality, contemporary design, and superb finish, make the Shield Showcase a market leading solution. Available in a choice of 9 sizes, each designed to occupy a given number of A4 sheets of paper from two to as many as eighteen. Top hinged doors include support stays and are fitted with two locks (matching keys). 6 frame colours and 18 cloth colours.

Illuminated models, using cold cathode lights at the top of the units, are available upon request.

### TO ORDER:

Please state the product code followed by the frame colour code and then the code of the cloth colour required.

EXAMPLE: 1050 x 1397mm with aluminium frame and royal blue loop nylon cloth = **SCP18/AL/RB**



Size H 450mm  
W 537mm  
Takes 2 x A4 portrait  
Code **SCP2**



Size H 570mm  
W 407mm  
Takes 2 x A4 landscape  
Code **SCL2**



Size H 570mm  
W 712mm  
Takes 4 x A4 landscape  
Code **SCL4**



Top hinged with support stays

Frame colours - see page 64



Standard loop nylon cloth colours - see page 63



Size H 750mm  
W 537mm  
Takes 4 x A4 portrait  
Code **SCP4**

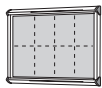

Size H 750mm  
W 967mm  
Takes 8 x A4  
Code **SCL8**

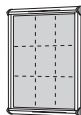

Size H 1050mm  
W 752mm  
Takes 9 x A4  
Code **SCP8**



SCRP15/BK/OR

Coloured frame



Aluminium frame

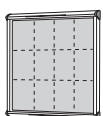

Size H 1050mm  
W 1012mm  
Takes 12 x A4  
Code **SCP12**

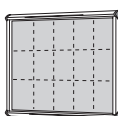

Size H 1050mm  
W 1182mm  
Takes 15 x A4  
Code **SCP15**

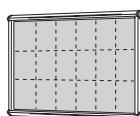

Size H 1050mm  
W 1397mm  
Takes 18 x A4  
Code **SCP18**

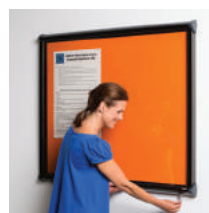

# Shield® Resist-a-Flame® showcase with top hinged doors

Fire resistant version of our popular interior showcases

High quality, contemporary design and finish, make the Shield® Showcase a market leading solution. Cloth and pinboard core tested to BS EN 13501. Clear covers tested to BS 476 part 7 class 1Y. Available in a choice of 9 sizes, designed to occupy a given number of A4 sheets. Top hinged doors have support stays and two matching locks. 6 frame colours and 11 woven cloth colours to choose from.

Illuminated models, using cold cathode lights at the top of the units, are available upon request.

**TO ORDER:**

Please state the product code followed by the frame colour code and then the code of the cloth colour required.

EXAMPLE: 1050 x 752mm with blue frame and silver cloth = **SCRP8/BL/SL**



SCRP8/BL/SL

**Frame colours** - see page 64



**Resist-a-Flame® woven cloth colours** - see page 63



Size H 450mm  
W 537mm  
Takes 2 x A4 portrait  
Code **SCRP2**



Size H 570mm  
W 407mm  
Takes 2 x A4 landscape  
Code **SCRL2**



Size H 570mm  
W 712mm  
Takes 4 x A4 landscape  
Code **SCRL4**



Size H 750mm  
W 537mm  
Takes 4 x A4 portrait  
Code **SCRP4**

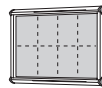

Size H 750mm  
W 967mm  
Takes 8 x A4  
Code **SCRL8**



Size H 1050mm  
W 752mm  
Takes 9 x A4  
Code **SCRP8**

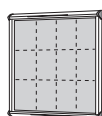
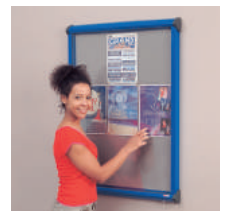

Size H 1050mm  
W 1012mm  
Takes 12 x A4  
Code **SCRP12**

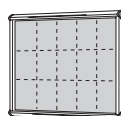

Size H 1050mm  
W 1182mm  
Takes 15 x A4  
Code **SCRP15**

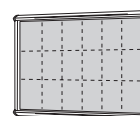

Size H 1050mm  
W 1397mm  
Takes 18 x A4  
Code **SCRP18**

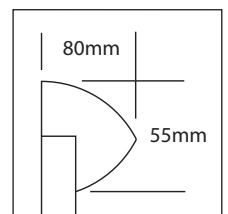

**Standard or Resist-a-Flame?**  
Do you comply with public area building regulations?  
go to: [www.resistaflame.com](http://www.resistaflame.com)

**NEW EUROPEAN REACTION TO FIRE TEST**  
When tested to the relevant European 'Reaction to Fire' tests, this product was classified B-SI, d0 according to BS-EN 13501-1.  
This classification identifies that this product can be used in the same areas as products tested to BS476 Parts 6 and 7 and classified as class 0 according to UK building regulations.

# Noticeboards - Shield® Exterior



SCEP18/AL/RB

## Shield® exterior showcases ex-stock options

Popular colour combinations of this weatherproof showcase are now available from stock

Market leading weatherproof showcase offering a contemporary design, independently certified to ip55 requirements of EN60529 against water and dust ingress. Top hinged doors include support stays and are fitted with two locks with matching keys. The 4 most popular sizes, each designed to occupy 8, 12, 15 or 18 sheets of A4 paper are now available for immediate delivery. For full size and colour range see opposite page.



SCEP18/AL/CK



These products have been independently tested and comply with the IP55 requirements for dust and water ingress of BS EN 60529

### Aluminium Frame / Cork

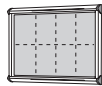

Size H 750mm  
W 967mm  
Takes 8 x A4  
Aluminium Frame  
Cork **SCEL8/AL/CK**

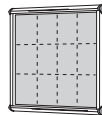

Size H 1050mm  
W 1012mm  
Takes 12 x A4  
Aluminium Frame  
Cork **SCEP12/AL/CK**

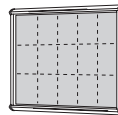

Size H 1050mm  
W 1182mm  
Takes 15 x A4  
Aluminium Frame  
Cork **SCEP15/AL/CK**

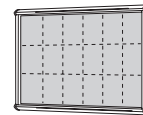

Size H 1050mm  
W 1397mm  
Takes 18 x A4  
Aluminium Frame  
Cork **SCEP18/AL/CK**



### Aluminium Frame / Blue Cloth

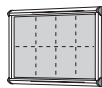

Size H 750mm  
W 967mm  
Takes 8 x A4  
Aluminium Frame  
Blue Cloth **SCEL8/AL/RB**

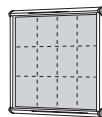

Size H 1050mm  
W 1012mm  
Takes 12 x A4  
Aluminium Frame  
Blue Cloth **SCEP12/AL/RB**

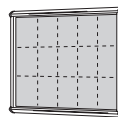

Size H 1050mm  
W 1182mm  
Takes 15 x A4  
Aluminium Frame  
Blue Cloth **SCEP15/AL/RB**

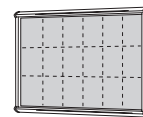

Size H 1050mm  
W 1397mm  
Takes 18 x A4  
Aluminium Frame  
Blue Cloth **SCEP18/AL/RB**

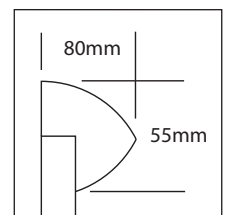

# Shield® exterior showcases full range

Deluxe weatherproof showcase, with full independent ip55 certification designed for wall mounting

Market leading exterior showcase offering coloured frame options and a contemporary design. Independently certified to ip55 requirements of EN60529 against water and dust ingress. Available in a choice of seven sizes, each designed to occupy a given number of A4 sheets of paper. Top hinged doors include support stays and are fitted with two locks with matching keys. A choice of 6 frame colours combine with any of 18 exterior cloth options, or traditional pinnable cork.

### Illuminated versions

Fitted with cold cathode lights at the top of the unit.

### TO ORDER:

Please state the product code followed by the frame colour code and then the code of the cloth colour required.  
EXAMPLE: 1050 x 1397mm with green frame and light grey woven cloth = **SCEP18/GR/LG**



SCEP4/BK/CK

### Frame colours - see page 64



### Standard loop nylon cloth colours - see page 63

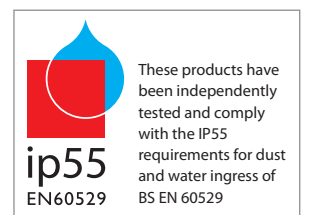

Size H 570mm  
W 712mm  
Takes 4 x A4  
Code **SCEL4**  
Illuminated **SCEXL4**



Size H 750mm  
W 537mm  
Takes 4 x A4  
Code **SCEP4**  
Illuminated **SCEXP4**

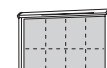

Size H 750mm  
W 967mm  
Takes 8 x A4  
Code **SCEL8**  
Illuminated **SCEXL8**

### Coloured frame



### Aluminium frame

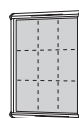

Size H 1050mm  
W 752mm  
Takes 9 x A4  
Code **SCEP8**  
Illuminated **SCEXP8**

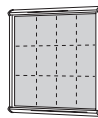

Size H 1050mm  
W 1012mm  
Takes 12 x A4  
Code **SCEP12**  
Illuminated **SCEXP12**

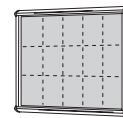

Size H 1050mm  
W 1182mm  
Takes 15 x A4  
Code **SCEP15**  
Illuminated **SCEXP15**

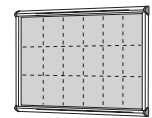

Size H 1050mm  
W 1397mm  
Takes 18 x A4  
Code **SCEP18**  
Illuminated **SCEXP18**



SCES18/GR/LG

## Shield® Exterior Showcases with sunken posts

Post mounted weatherproof showcase for securing into concrete

A Shield® exterior showcase with the addition of a powder coated steel backing plate for additional weatherproofing. Galvanised and powder coated heavy duty steel posts to take single or double sided showcases. Two posts for concreting into the ground. Finished height of the unit is 2 metres. Available in 4 size options, supplied as a single showcase with a pair of posts. An extra showcase is available to create a double sided unit.

### TO ORDER:

Please state the product code followed by the frame colour code and then the code of the cloth colour required  
EXAMPLE: 1050 x 1397mm with sunken posts, green frame and light grey cloth = **SCES18/GR/LG**

### Frame colours - see page 64



### Standard loop nylon cloth colours - see page 63



### Coloured frame



### Aluminium frame



### Sunken Posts

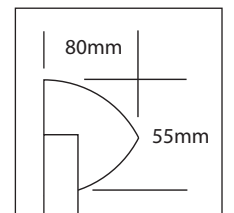
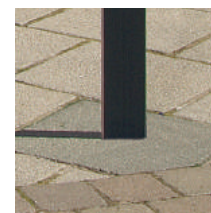
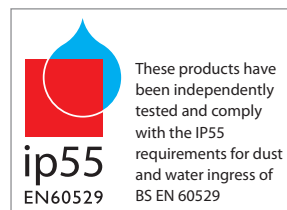
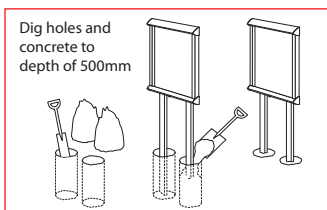

Diagram	Size	H	W	Takes	Showcase with sunken posts	Extra showcase
	Size	H 1050mm	W 752mm	Takes 9 x A4	Showcase with sunken posts <b>SCES8</b>	Extra showcase <b>SCED8</b>
	Size	H 1050mm	W 1012mm	Takes 12 x A4	Showcase with sunken posts <b>SCES12</b>	Extra showcase <b>SCED12</b>
	Size	H 1050mm	W 1182mm	Takes 15 x A4	Showcase with sunken posts <b>SCES15</b>	Extra showcase <b>SCED15</b>
	Size	H 1050mm	W 1397mm	Takes 18 x A4	Showcase with sunken posts <b>SCES18</b>	Extra showcase <b>SCED18</b>





# Shield® Exterior Showcases with surface mounted posts

Post mounted weatherproof showcase for bolting into a concrete base

A Shield® exterior showcase with the addition of powder coated steel backing plate for rear weatherproofing. Galvanised and powder coated heavy duty steel posts to take single or double sided showcases. 2 posts are supplied for bolting down onto solid concrete surface. Finished height of the unit is 2.0m. Available in 4 size options, supplied as a single showcase with a pair of posts. An extra showcase is available to create a double sided unit.

**TO ORDER:**

Please state the product code followed by the frame colour code and then the code of the cloth colour required  
 EXAMPLE: 1050 x 1397mm with bolt down posts, red frame and light grey cloth = **SCEB18/RD/LG**

**Frame colours - see page 64**



**Standard loop nylon cloth colours - see page 63**

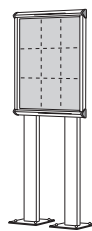

Size H 1050mm  
 W 752mm  
 Takes 9 x A4  
 Showcase with bolt down posts **SCEB8**  
 Extra showcase **SCED8**

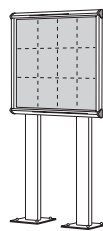

Size H 1050mm  
 W 1012mm  
 Takes 12 x A4  
 Showcase with bolt down posts **SCEB12**  
 Extra showcase **SCED12**

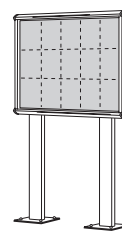

Size H 1050mm  
 W 1182mm  
 Takes 15 x A4  
 Showcase with bolt down posts **SCEB15**  
 Extra showcase **SCED15**

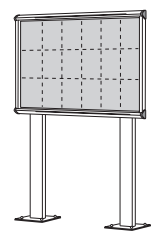

Size H 1050mm  
 W 1397mm  
 Takes 18 x A4  
 Showcase with bolt down posts **SCEB18**  
 Extra showcase **SCED18**



**Coloured frame**



**Aluminium frame**



**Bolt Down Posts**

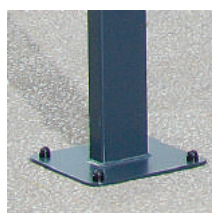

These products have been independently tested and comply with the IP55 requirements for dust and water ingress of BS EN 60529

Bolt into a sound concrete base

# Noticeboards - Freestanding



SSIS/RD/GM

## Shield® information board with lift off cover

### Lockable deluxe noticeboard

Range of freestanding noticeboards with a simple lift off lockable cover to protect your notice from casual interference. A choice of stand height is available to suit the application and noticeboard. The 1.8m stand versions for larger, higher and upright boards. The 1m stand versions with adjustable bracket can be mounted vertically or at a 45° angle, perfect for menu-board applications. Available in 5 frame colour options, complimented with a choice of 18 cloth options.

### TO ORDER:

Please state the product code followed by the frame colour code and then the code of the cloth colour required.  
EXAMPLE: 735 x 491mm with red frame and gun metal cloth = **SSIS/RD/GM**

### Frame colours - see page 64



Aluminium Blue Green Red White

### Standard loop nylon cloth colours - see page 63



Ink Navy Royal Blueberry Dk Wine Scarlet Yellow  
Bottle Green Emerald Quince Black Gunmetal Lt Grey  
Purple Magenta Lilac Orange Cyan Apple



Board Size H 446mm  
W 491mm  
Takes 2 x A4  
Max Height 1223mm  
Code **ES1S**



Board Size H 735mm  
W 491mm  
Takes 4 x A4  
Max Height 1368mm  
Code **SS1S**



Board Size H 735mm  
W 491mm  
Takes 4 x A4  
Stand Height 1800mm  
Code **SS1LS**



Board Size H 1037mm  
W 720mm  
Takes 9 x A4  
Stand Height 1800mm  
Code **SM1LS**



SM1LS/WH/RB

Coloured frame

Aluminium frame

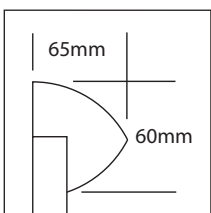

# Shield® information board with hinged cover

## Lockable freestanding showcase

Range of deluxe freestanding noticeboards with hinged lockable door. The top hinged door has support stays and two locks with matching keys. The substantial heavy duty base creates a very stable stand, which is available at 1.0m or 1.8m heights.

The 1.8m stand for larger, higher and upright applications. The 1m stand version with adjustable bracket can be mounted vertically or at a 45° angle, perfect for menu board applications. Available in 6 frame colour options, complimented with a choice of 18 cloth options.

### TO ORDER:

Please state the product code followed by the frame colour code and then the code of the cloth colour required.  
EXAMPLE: 450 x 537mm with aluminium frame and black cloth = **SP2SS/AL/BK**

### Frame colours - see page 64



### Standard loop nylon cloth colours - see page 63



SP2SS/AL/BK



Board Size H 450mm  
W 537mm  
Takes 2 x A4P  
Max Height 1225mm  
Code **SP2SS**

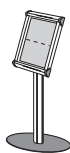

Board Size H 570mm  
W 407mm  
Takes 2 x A4L  
Max Height 1285mm  
Code **SL2SS**

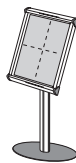

Board Size H 750mm  
W 537mm  
Takes 4 x A4P  
Max Height 1375mm  
Code **SP4SS**



Board Size H 570mm  
W 712mm  
Takes 4 x A4L  
Stand Height 1800mm  
Code **SL4LS**

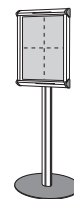

Board Size H 750mm  
W 537mm  
Takes 4 x A4P  
Stand Height 1800mm  
Code **SP4LS**

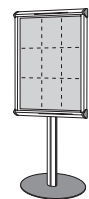

Board Size H 1050mm  
W 752mm  
Takes 9 x A4P  
Stand Height 1800mm  
Code **SP8LS**

SP2SS/AL/BK



SP8LS/BL/LG



Coloured frame



Aluminium frame

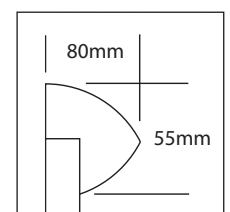

# Noticeboards - Freestanding



FNB32/DB

## Pinnable foyer noticeboards

### Practical freestanding noticeboard

An angled noticeboard mounted portrait on a white coated steel stand. Ideal for notices in foyers and reception areas. Board is 900 x 600mm with an overall height of 1800mm. Noticeboard available in a choice of four fabric colours.

#### TO ORDER:

Please state the product code followed by the code of the cloth colour required.

EXAMPLE: Noticeboard with blue felt cloth = **FNB32/DB**

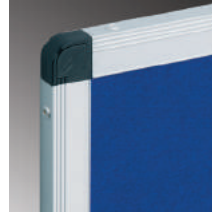

#### Felt colours - see page 62



Board Size H 900mm  
W 600mm  
Stand Height 1800mm  
Code **FNB32**

## Shield® Design foyer noticeboards

### Deluxe framed noticeboard on contemporary heavy duty stand

This freestanding noticeboard has an adjustable bracket to enable the noticeboard to be mounted perpendicular or up to 45° angle. Board can be mounted landscape or portrait. Available in 6 frame colour options, with a choice of 18 cloth options or traditional cork. Accepts pins or Velcro®.

#### TO ORDER:

Please state the product code followed by the frame colour code and then the code of the cloth colour required.  
EXAMPLE: 900 x 600mm with blue frame and light grey cloth = **SNL015/BL/LG**

#### Frame colours - see page 64



Aluminium Blue Green Red White Black

#### Standard loop nylon cloth colours - see page 63



Ink Navy Royal Blueberry Dk Wine Scarlet Yellow  
Bottle Green Emerald Quince Black Gunmetal Lt Grey  
Purple Magenta Lilac Orange Cyan Apple  
Cork

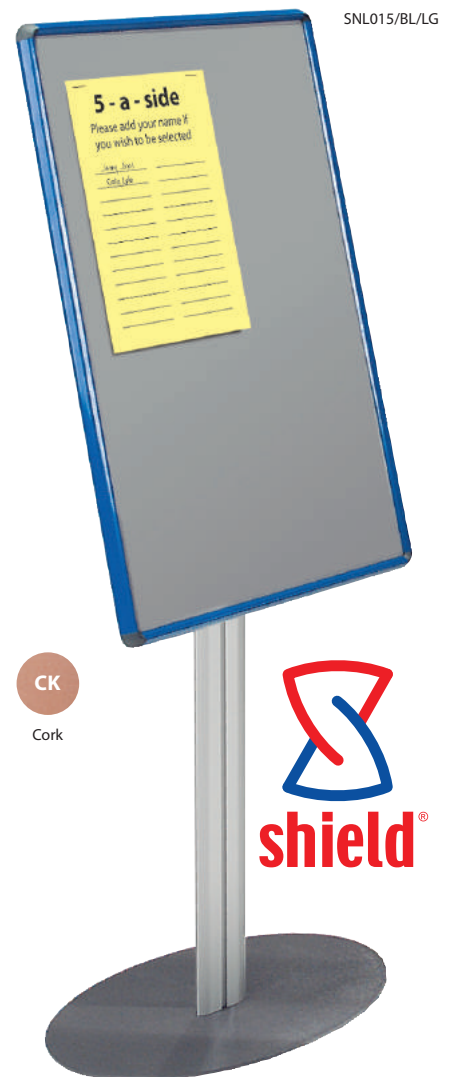

SNL015/BL/LG

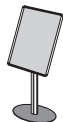

Board Size H 600mm  
W 450mm  
Stand Height 1000mm  
Code **SNL005**

Board Size H 900mm  
W 600mm  
Stand Height 1000mm  
Code **SNL015**



Coloured frame



Aluminium frame

# Double sided mobile noticeboards

An aluminium framed mobile noticeboard with locking castors

Double sided height adjustable aluminium framed noticeboard is mounted on a stable powder coated steel stand. Available in a choice of 5 colours and in 6 sizes.

**Resist-a-Flame®**

Fire resistant version fully constructed and tested to meet the latest building and fire regulations. Ideal for use in public buildings and industrial applications. Full assembled board certified to BS EN 13501. Available in a choice of 5 woven cloth colours.

**TO ORDER:**

Please state the product code followed by the colour code of the cloth required.

EXAMPLE: 1200 x 1800mm in green felt cloth

= **M411L/GR**



**Felt cloth colours** - see page 62

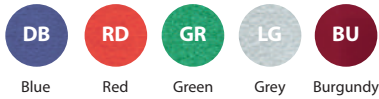

**Resist-a-Flame® woven cloth colours** - see page 63

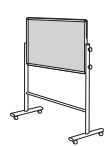

Board Size H 900mm  
W 1200mm  
Height 1875mm  
Standard **M391L**  
Resist-a-Flame® **RM391L**

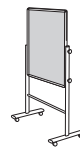

Board Size H 1200mm  
W 900mm  
Height 2030mm  
Standard **M391P**  
Resist-a-Flame® **RM391P**

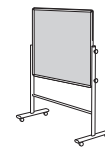

Board Size H 1200mm  
W 1200mm  
Height 2030mm  
Standard **M401S**  
Resist-a-Flame® **RM401S**

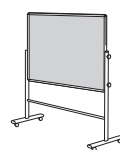

Board Size H 1200mm  
W 1500mm  
Height 2030mm  
Standard **M454L**  
Resist-a-Flame® **RM454L**

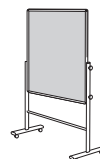

Board Size H 1500mm  
W 1200mm  
Height 2130mm  
Standard **M454P**  
Resist-a-Flame® **RM454P**

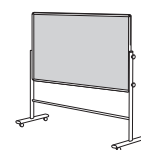

Board Size H 1200mm  
W 1800mm  
Height 2000mm  
Standard **M411L**  
Resist-a-Flame® **RM411L**

RM411L/SL





**Standard or Resist-a-Flame?**  
Do you comply with public area building regulations?  
go to: [www.resistaflame.com](http://www.resistaflame.com)

**NEW EUROPEAN REACTION TO FIRE TEST**  
When tested to the relevant European 'Reaction to Fire' tests, this product was classified B-S1, d0 according to BS-EN 13501-1.  
This classification identifies that this product can be used in the same areas as products tested to BS476 Parts 6 and 7 and classified as class 0 according to UK building regulations.

# Noticeboards - Mobile



## Combi mobile information board

Freestanding board with whiteboard one side, noticeboard on reverse

A versatile mobile board offering both pinboard and whiteboard applications in one product. Height adjustable. Whiteboard surface also accepts magnets. Available in two popular sizes and mounted on a stable powder coated steel frame, with four castors two of which are lockable. A1 flip pad clamp on all whiteboard surfaces.

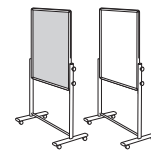

Board Size H 1200mm  
W 700mm  
Code **448050**

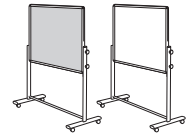

Board Size H 1000mm  
W 1000mm  
Code **448051**



## Height adjustable mobile noticeboards

Double sided mobile pinnable panels framed in anodised aluminium and mounted on sturdy white frame with locking castors

These height adjustable panels can be mounted in either portrait or landscape formats. Pinnable noticeboards are available in a choice of blue, red, green or grey cloth. Drywipe whiteboard option also available in all 4 sizes, one side is plain, reverse has a faint Guideline® grid.

### TO ORDER:

Please state the product code followed by the colour code of the cloth required.

EXAMPLE: 1200 x 1800mm in royal blue cloth = **MNB64/RB**

Loop nylon cloth colours - see page 63



MNB64/RB

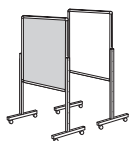

Board Size H 1200mm  
W 900mm  
Loop Nylon **MNB43**  
Whiteboard **MWB43**

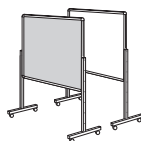

Board Size H 1200mm  
W 1200mm  
Loop Nylon **MNB44**  
Whiteboard **MWB44**

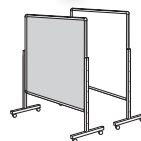

Board Size H 1500mm  
W 1200mm  
Loop Nylon **MNB54**  
Whiteboard **MWB54**

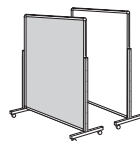

Board Size H 1800mm  
W 1200mm  
Loop Nylon **MNB64**  
Whiteboard **MWB64**

Loop Nylon Pinnable



Drywipe Whiteboard



# Mobile - Noticeboards

## Wood mobile noticeboard/dividers

A range of premium handmade beech framed boards

Double sided boards available in 3 sizes of loop nylon faced noticeboard or drywipe whiteboard. Heavy duty frame made from quality lacquered beech sourced from sustainable forests. Edges of the board are rounded for increased safety. Heavy duty wooden feet ensure stability when free standing; wheels are provided if mobility is required. Whiteboard version features a plain drywipe surface to one side, while the reverse has a faint Guideline® grid to aid writing.



DJS64/RD



DJS46/WB



DJS44/BL

Whiteboard option

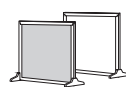

Size H 1200mm  
W 1200mm  
Blue **DJS44/BL**  
Red **DJS44/RD**  
Whiteboard **DJS44/WB**

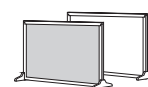

Size H 1200mm  
W 1800mm  
Blue **DJS46/BL**  
Red **DJS46/RD**  
Whiteboard **DJS46/WB**

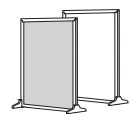

Size H 1800mm  
W 1200mm  
Blue **DJS64/BL**  
Red **DJS64/RD**  
Whiteboard **DJS64/WB**

# Noticeboards - Colour Swatches

## Felt fabric

Pages: 4, 8, 14, 15, 24, 26, 30, 31, 32, 38, 58, 59

The standard noticeboard material is pinnable and Velcro® friendly.



## Traditional Cork

Pages: 13, 14, 15, 20, 25, 27, 30, 31, 38, 52, 53, 54, 55, 58

The traditional covering for pinnable noticeboards, not suitable for Velcro®.



## ColourPlus® fabric

Pages: 5, 9, 16, 33, 39

A NEW vibrantly coloured fabric suitable for use with pins.



## Recycled board

Pages: 7, 12, 28, 29, 37

This range of uncovered pinnable board material is made from recycled newsprint and has no fabric covering.





## Shield® loop nylon fabric

Pages: 17, 18, 21, 22, 40, 41, 44, 45, 46, 48, 50, 52, 53, 54, 55, 56, 57, 58, 60, 61

The loop nylon range is pinnable and also accepts Velcro®, now with the addition of 6 extra vibrant colourways



## Resist-a-Flame® woven fabric

Pages: 6, 10, 11, 19, 23, 34, 35, 36, 42, 43, 45, 47, 49, 51, 59

Fire retardant woven cloths fully tested individually and as a composite with the Resist-a-Flame® core to conform to regulations for fire resistancy in public area buildings.

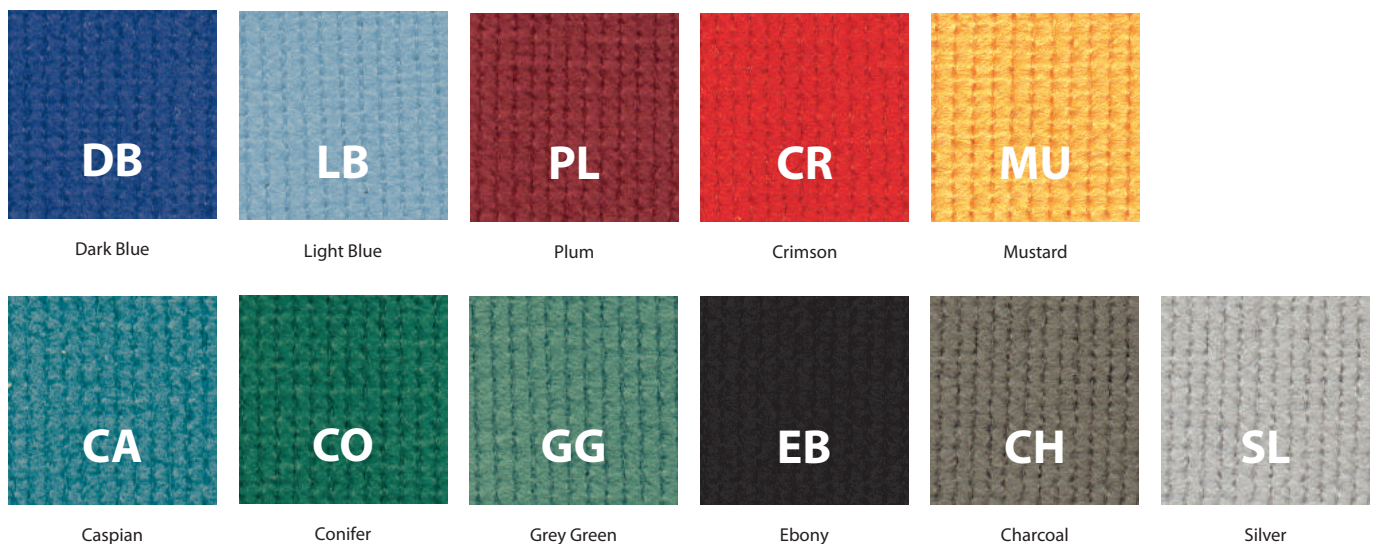

# Noticeboards - Colour Swatches

## Shield® range of frames

Pages: Shield® Design - 16 to 23 and 39-58

The Shield® range of contemporary noticeboards and showcases offer a cohesive design style in a choice of 6 frame colours across the entire range. Stocked colour combinations are available as well as the opportunity to combine with any of our loop nylon or Resist-a-Flame® cloth options to fit your specific requirements..



Anodised Aluminium



Blue - RAL5017



Red - RAL3020



Green - RAL6029



White - RAL9003



Black - RAL9005

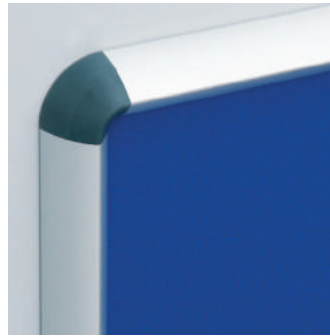

Shield® Design Noticeboards



Shield® Design Tamperproof Noticeboards



Shield® Showcase with lift off cover



Shield® Showcase with top hinged doors



# WriteOn® Whiteboards

- 66 - 67 Coloured Edge Whiteboards
- 68 - 71 Aluminium Framed Whiteboards
- 72 - 73 Shield® Design Whiteboards
- 74 Eco-friendly Whiteboards
- 75 - 76 Glass Drywipe Boards
- 76 - 77 Projection Whiteboards
- 78 - 80 Mobile Whiteboards
- 81 Freestanding Whiteboards
- 82 - 83 Printed Whiteboards
- 84 - 85 Drywipe Planners
- 86 - 87 Drywipe Sports Boards
- 83, 88 Drywipe Maps
- 89 - 92 Whiteboard Accessories



# WriteOn® Whiteboards - Colour Edged



49354/BL

## WriteOn® coloured edge whiteboards

Attractive frameless design with tough ABS colour edging that adds a modern accent to an everyday product

Mounts flush to the wall due to its frameless design and simple through the board fixing. Edged in a choice of six bright colours with matching screw caps. This double sided whiteboard features one side plain with a feint Guideline® grid to aid writing on the reverse. Low profile 2mm edge means boards can be mounted side by side virtually seamlessly, especially with white edging. Ideal for mounting alongside printed boards - see page 82.

### TO ORDER:

Please state the product code followed by the edge colour code required

EXAMPLE: 1200mm x 1500mm board with blue edging = **49354/BL**



FOR DRYWIPE ACCESSORIES - SEE PAGES 89 - 92

### Edge colours

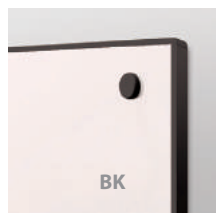

BK

Black



WH

White



BL

Blue

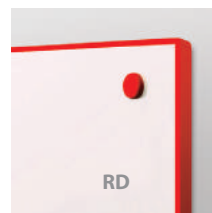

RD

Red

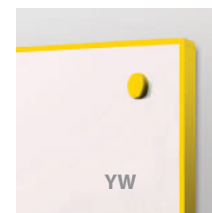

YW

Yellow

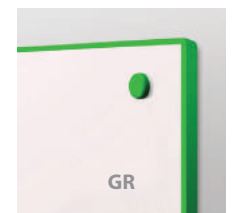

GR

Green



Size H 600mm  
W 900mm  
Code **49332**



Size H 900mm  
W 1200mm  
Code **49343**

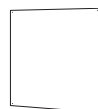

Size H 1200mm  
W 1200mm  
Code **49344**



### Whiteboard accessory kit

2 x self adhesive steel disks  
2 x 25mm magnets  
Self adhesive pen holder  
(pen not included).

Code **439201**



Size H 1200mm  
W 1500mm  
Code **49354**



Size H 1200mm  
W 1800mm  
Code **49364**



Size H 1200mm  
W 2400mm  
Code **49384**



Please note these boards are frameless so sizes shown are nominal

4 x 59364



## WriteOn® whiteboard wall

### Create a continuous drywipe whiteboard wall

The tough ABS edged whiteboards mount flush to the wall and each other due to their frameless design, and simple through the board fixing. White cover caps mask the fixings. This double sided whiteboard features one side plain with a faint Guideline® grid to aid writing on the reverse. Please see some suggestions below on how to cover specific wall dimensions. There are 6 standard sizes to choose from. Special sizes can be produced, prices by quotation.



Size H 578mm  
W 876mm  
Code **59332**



Size H 876mm  
W 1176mm  
Code **59343**

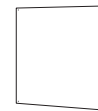

Size H 1176mm  
W 1176mm  
Code **59344**



Size H 1176mm  
W 1476mm  
Code **59354**



Size H 1176mm  
W 1779mm  
Code **59364**

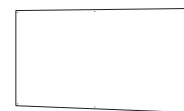

Size H 1176mm  
W 2379mm  
Code **59384**



**Whiteboard accessory kit**  
2 x self adhesive steel disks  
2 x 25mm magnets  
Self adhesive pen holder (pen not included).

Code **439201**

### Sample layouts

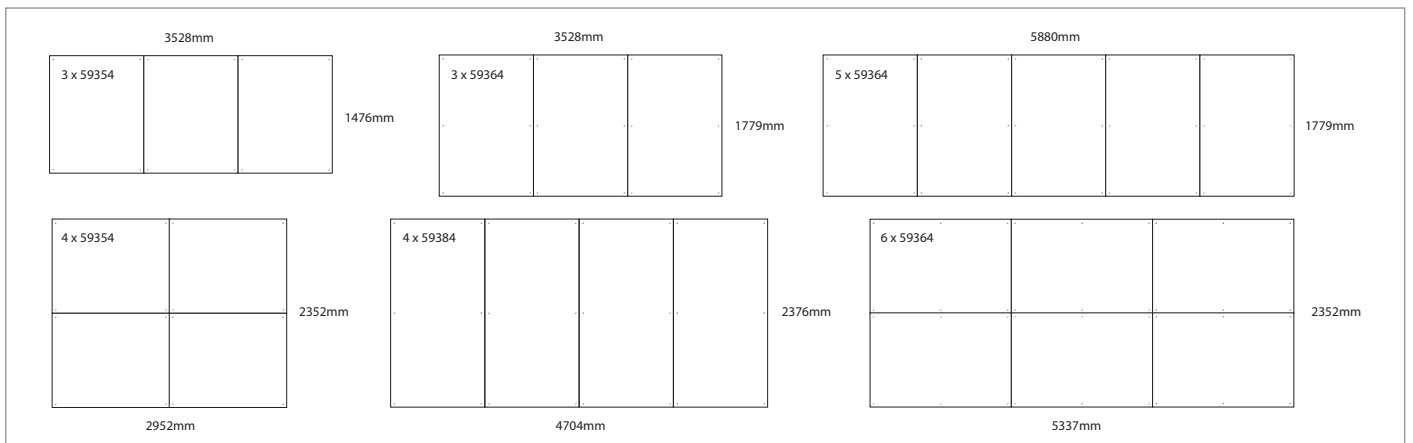

# WriteOn® Whiteboards - Aluminium Framed

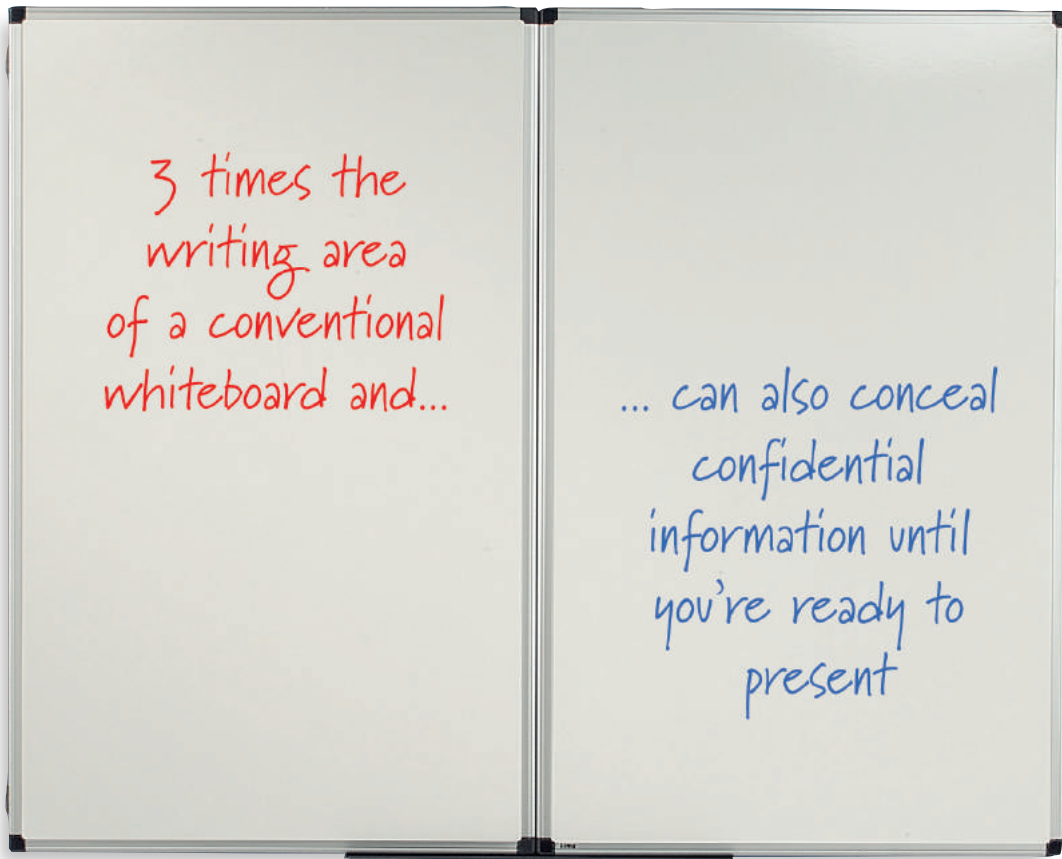

BLB1003 - Closed



## WriteOn® spacesaver whiteboards

Three times the surface area of the wall space they take up

The Spacesaver whiteboard mounts just like an ordinary whiteboard but with hinged double sided panels that create additional writing areas. Can also be used for revealing pre-prepared work or covering confidential information.

Available in a range of sizes, with single or double fold out panels and magnetic or non-magnetic surfaces. Supplied with pen tray and concealed through the corner fixings.

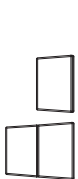

Closed H 900mm  
W 600mm  
Open H 900mm  
W 1200mm  
Laminate **BLB1000**  
Magnetic **BWB1000**

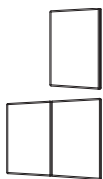

Closed H 1200mm  
W 900mm  
Open H 1200mm  
W 1800mm  
Laminate **BLB1001**  
Magnetic **BWB1001**

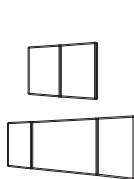

Closed H 900mm  
W 1200mm  
Open H 900mm  
W 2400mm  
Laminate **BLB1002**  
Magnetic **BWB1002**

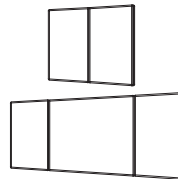

Closed H 1200mm  
W 1500mm  
Open H 1200mm  
W 3000mm  
Laminate **BLB1003**  
Magnetic **BWB1003**

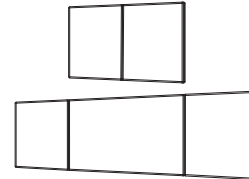

Closed H 1200mm  
W 2000mm  
Open H 1200mm  
W 4000mm  
Laminate **BLB1004**  
Magnetic **BWB1004**

BLB1003 - Open

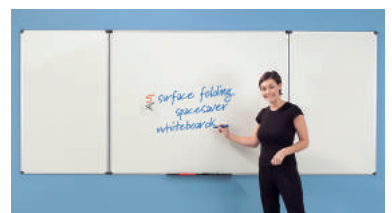

47164

Double-sided drywipe whiteboards  
 Plain surface on one side  
 Guideline® gridded surface on the reverse

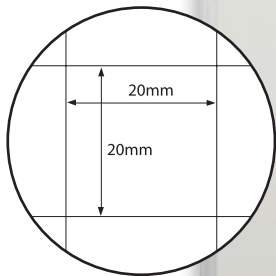

## WriteOn® dual faced whiteboards

Double sided drywipe whiteboard which offers one side plain ultrasmooth surface with gridded Guideline® surface on the other

Aluminium framed whiteboards available in a wide range of sizes. The Guideline® side has a faint 20mm square grid that assists the presenter, but is unseen by the audience. Supplied with pen tray and concealed through the corner wall fixings. For use with drywipe pens. Can be mounted landscape or portrait.



47143



47164



FOR MATCHING NOTICEBOARDS - SEE PAGE 8 - 15



Size H 450mm  
W 600mm  
Code **47131**



Size H 900mm  
W 600mm  
Code **47132**



Size H 1200mm  
W 900mm  
Code **47143**



Size H 1200mm  
W 1200mm  
Code **47144**



Size H 1200mm  
W 1500mm  
Code **47154**



Size H 1200mm  
W 1800mm  
Code **47164**



Size H 1200mm  
W 2400mm  
Code **47184**



Size H 1200mm  
W 2700mm  
Code **47194**

# WriteOn® Whiteboards - Aluminium Framed



## WriteOn® magnetic whiteboards

Superior coated steel writing surface that also accepts magnets

Excellent hardwearing surface for higher use applications. For use with drywipe pens. All boards 1800mm and over have extra central fixings for additional safety. Can be mounted landscape or portrait. Aluminium frame supplied with pen tray, concealed corner mounting and fixings. Surface guaranteed for 5 years.



Size H 450mm  
W 600mm  
Coated Steel **49631**



Size H 900mm  
W 600mm  
Coated Steel **49632**



Size H 1200mm  
W 900mm  
Coated Steel **49643**



Size H 1200mm  
W 1200mm  
Coated Steel **49644**

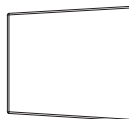

Size H 1200mm  
W 1500mm  
Coated Steel **49654**



Size H 1200mm  
W 1800mm  
Coated Steel **49664**



Size H 1200mm  
W 2400mm  
Coated Steel **49684**



Size H 1200mm  
W 2700mm  
Coated Steel **49694**

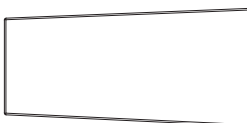

Size H 1200mm  
W 3000mm  
Coated Steel **49610**

**Extended Range**

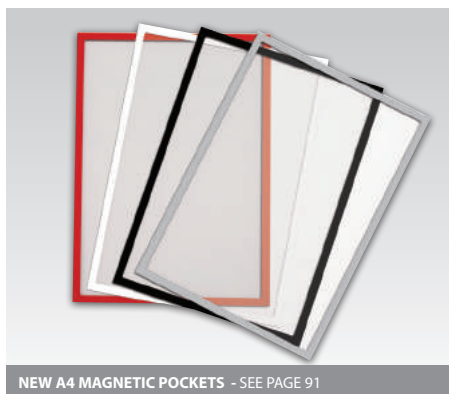

NEW A4 MAGNETIC POCKETS - SEE PAGE 91







## WriteOn® vitreous enamel steel magnetic whiteboards

### The ultimate surface for high use applications

Vitreous Enamelled Steel surface is accepted as the ultimate drywipe surface. The enamel coating is baked at over 800°C, giving it a durable hardwearing surface that we guarantee for 25 years use. The surface also has the advantage of accepting magnets to affix maps/charts, prepared notes and posters. Aluminium framed boards are available in a choice of 8 popular sizes, and supplied with pen tray and concealed through the corner fixings. Larger boards have additional centre supports.



FOR DRYWIPE ACCESSORIES - SEE PAGES 89 - 92



Size H 450mm  
W 600mm

YES **49431**



Size H 900mm  
W 600mm

YES **49432**



Size H 1200mm  
W 900mm

YES **49443**

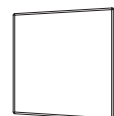

Size H 1200mm  
W 1200mm

YES **49444**



Size H 1200mm  
W 1500mm

YES **49454**

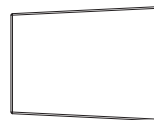

Size H 1200mm  
W 1800mm

YES **49464**



Size H 1200mm  
W 2400mm

YES **49484**



Size H 1200mm  
W 2700mm

YES **49494**



# WriteOn® Whiteboards - Shield® Design



Shield® Design  
Aluminium frame



Shield® Design  
Coloured frame



SW64/AL

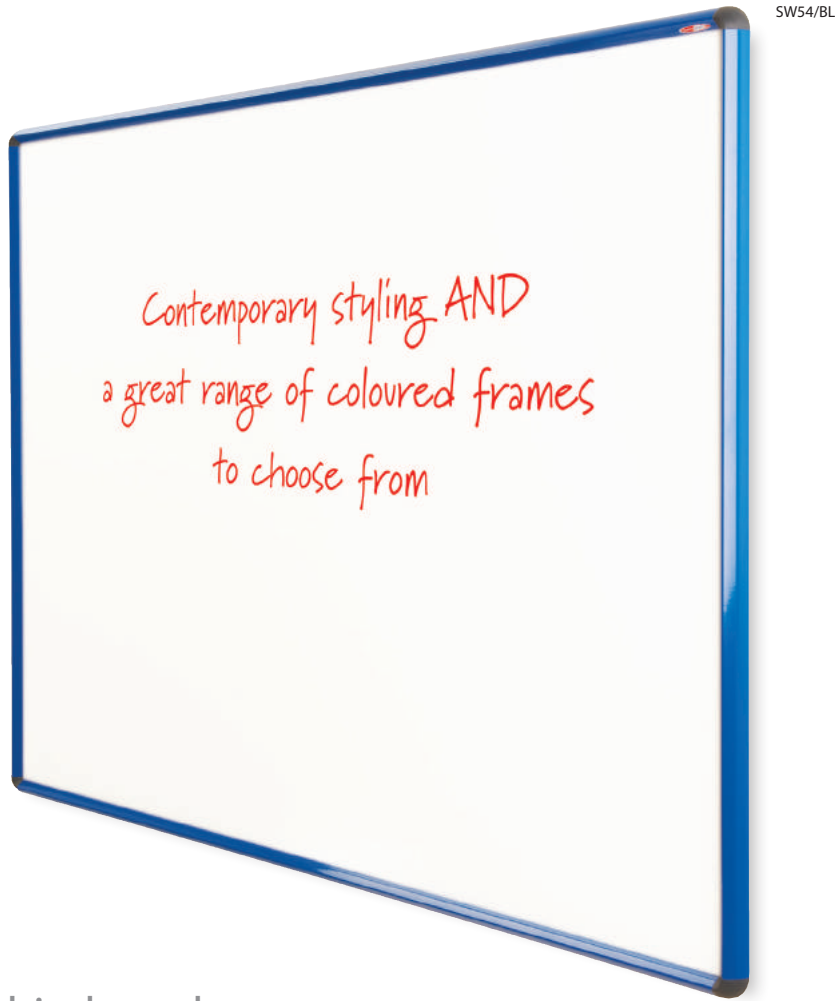

## Shield® Design whiteboards

### Deluxe contour framed whiteboard

The stylish frame is available in a range of 5 bright powder coat colours, or satin anodised aluminium finish. Available in a choice of 7 popular sizes supplied with concealed through the corner fixings. Part of the Shield® range of co-ordinated display and presentation products.

#### TO ORDER:

Please state the product code followed by the frame colour code required.

EXAMPLE: 1200 x 1500mm with blue frame = **SW54/BL**



Size H 600mm  
W 450mm  
Code **SW31**



Size H 600mm  
W 900mm  
Code **SW32**

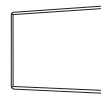

Size H 900mm  
W 1200mm  
Code **SW43**

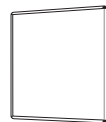

Size H 1200mm  
W 1200mm  
Code **SW44**

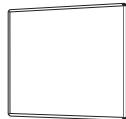

Size H 1200mm  
W 1500mm  
Code **SW54**

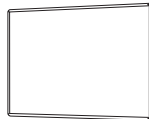

Size H 1200mm  
W 1800mm  
Code **SW64**



Size H 1200mm  
W 2400mm  
Code **SW84**

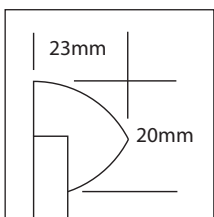

Frame colours - see page 64



FOR FREESTANDING  
VERSIONS - SEE PAGE 81

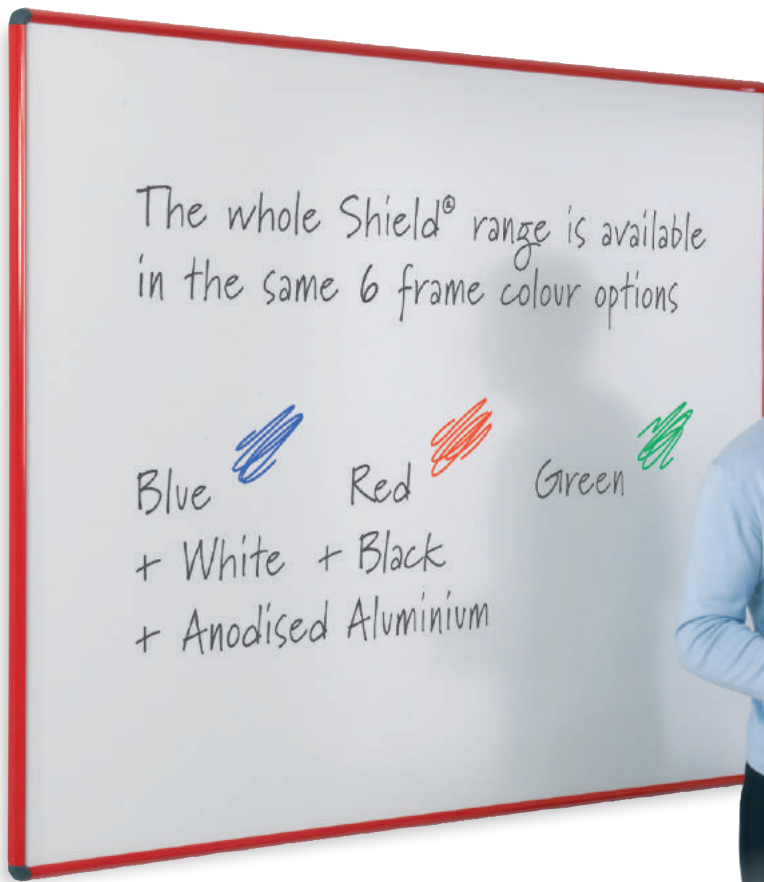

## Shield® Design magnetic whiteboards

The coloured frame Shield® whiteboard is now available with a coated steel magnetic surface

The stylish frame is available in a range of four bright powder coat colours, or satin anodised aluminium finish. Available in a choice of 6 popular sizes supplied with concealed through the corner fixings. Part of the Shield® range of co-ordinated display and presentation products.

### TO ORDER:

Please state the product code followed by the frame colour code required.

EXAMPLE: 1200 x 1500mm with red frame = **SWM54/RD**



Size H 600mm  
W 900mm  
Code **SWM32**

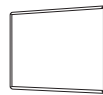

Size H 900mm  
W 1200mm  
Code **SWM43**

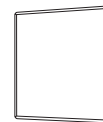

Size H 1200mm  
W 1200mm  
Code **SWM44**



Shield® Design Aluminium frame

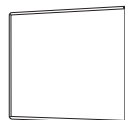

Size H 1200mm  
W 1500mm  
Code **SWM54**



Size H 1200mm  
W 1800mm  
Code **SWM64**



Size H 1200mm  
W 2400mm  
Code **SWM84**



Shield® Design Coloured frame



FOR DRYWIPE ACCESSORIES - SEE PAGES 89 - 92

Frame colours - see page 64

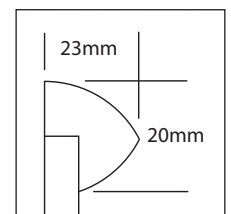

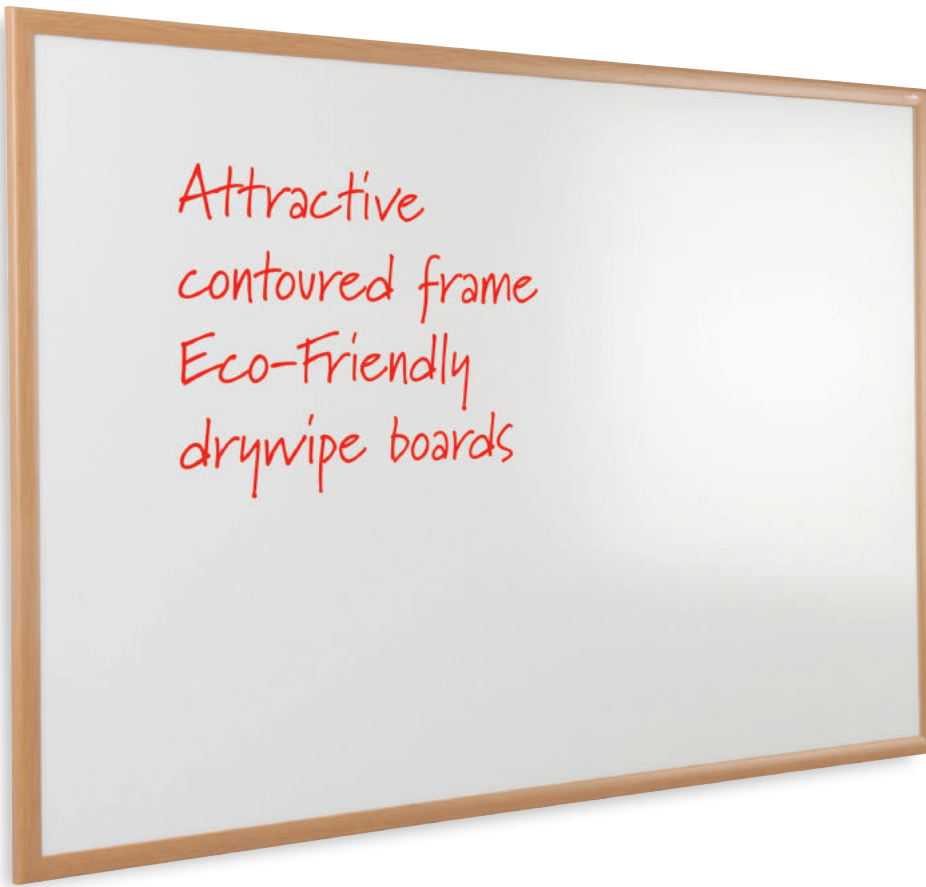

EFW1812/LO

## WriteOn® Eco-friendly whiteboards

Ever popular range offering an environmental choice at an economical price

Almost entirely constructed from timber industry bi-products and recycled materials. The attractive contoured 35mm wide frame is available in a choice of light oak effect, aluminium effect, blue or black finishes. Boards can be mounted portrait or landscape with fixings provided.



EFW1290/BL



Light Oak Effect



Aluminium Effect



Blue



Black



Size H 600mm  
W 900mm  
Light oak **EFW9060/LO**  
Aluminium **EFW9060/AL**  
Blue **EFW9060/BL**  
Black **EFW9060/BK**

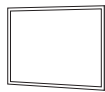

Size H 900mm  
W 1200mm  
Light oak **EFW1290/LO**  
Aluminium **EFW1290/AL**  
Blue **EFW1290/BL**  
Black **EFW1290/BK**

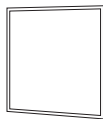

Size H 1200mm  
W 1200mm  
Light oak **EFW1212/LO**  
Aluminium **EFW1212/AL**  
Blue **EFW1212/BL**  
Black **EFW1212/BK**

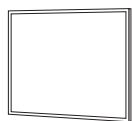

Size H 1200mm  
W 1500mm  
Light oak **EFW1512/LO**  
Aluminium **EFW1512/AL**  
Blue **EFW1512/BL**  
Black **EFW1512/BK**



Size H 1200mm  
W 1800mm  
Light oak **EFW1812/LO**  
Aluminium **EFW1812/AL**  
Blue **EFW1812/BL**  
Black **EFW1812/BK**



Size H 1200mm  
W 2400mm  
Light oak **EFW2412/LO**  
Aluminium **EFW2412/AL**  
Blue **EFW2412/BL**  
Black **EFW2412/BK**



FOR MATCHING NOTICEBOARDS - SEE PAGE 24 - 31

# WriteOn® magnetic glass whiteboards

The ultimate in contemporary drywipe presentations

The clean lines of this magnetic glass drywipe board is enhanced by the chrome mounts which float the board away from the wall. Available in a choice of 10 sizes from 500mm square up to 2.4 metres wide. The surface cleans easily with no ghosting. Made from toughened safety glass with a steel back. For use with super strength neodymium magnets. Optional matching glass pen tray available. All fixings included.



G1224/WH



FOR COLOURED GLASSBOARDS - SEE PAGE 117



Size H 500mm  
W 500mm

Code **G5050/WH**

Also available in coloured glass please see page 117



Size H 600mm  
W 450mm

Code **G4560/WH**

Also available in coloured glass please see page 117



Size H 900mm  
W 600mm

Code **G6090/WH**

Also available in black glass please see page 117



Size H 1000mm  
W 650mm

Code **G6510/WH**

Also available in black glass please see page 117



Size H 1000mm  
W 1500mm

Code **G1015/WH**



Size H 1000mm  
W 2000mm

Code **G1020/WH**



Size H 1200mm  
W 900mm

Code **G9012/WH**



Size H 1200mm  
W 1200mm

Code **G1212/WH**



Size H 1200mm  
W 1800mm

Code **G1218/WH**



Size H 1200mm  
W 2400mm

Code **G1224/WH**

Pen tray

Size W 300mm  
D 100mm

Code **G5000**



# WriteOn® Whiteboards - Projection



## WriteOn® glass projection board

New contemporary projection glass board, ideal for use within meeting rooms

Superior silver matte high contrast glass surface for projection combined with the added advantage of a dry wipe surface. Due to its steel backing the 4mm tempered glass board also accepts super strength neodymium magnets. Attractive chrome mounts fit through the board to float it away from the wall. Recommended projection area is within the fixings and can be used for both 16:10 and 16:9 Widescreen format projection up to a view width of 1700mm. Refresh surface with a whiteboard cleaning spray periodically.



### Glass projection board

Size H 1200mm  
W 1800mm  
View area H 1100mm  
W 1700mm  
Code **GP1218**



FOR GLASSBOARDS PENS - SEE PAGE 89



## Shield® Design projection whiteboards

### Semi-matte drywipe surface in 3 formats

The surface of these boards is top grade Japanese vitreous enamel steel guaranteed for 25 years. The semi-matte surface diffuses any 'hot spots' but obviously not to the extent of a totally matte projection screen cloth. Attractive Shield® contoured frame, powder coated black to add the professional touch. Balanced steel back to avoid distortion. Concealed corner fixings supplied. Refresh surface with a cleaning spray periodically.

NB Due to the heavy duty materials used in the construction of these steel boards, please ensure they are fixed to a solid wall.



Format 4:3  
View Area H 1181mm  
W 1575mm  
Overall H 1224mm  
W 1618mm  
Weight 27kg  
Code **PW1520**



Format 16:9  
View Area H 1181mm  
W 2100mm  
Overall H 1224mm  
W 2143mm  
Weight 35kg  
Code **PW1120**



Format 16:10  
View Area H 1181mm  
W 1890mm  
Overall H 1224mm  
W 1933mm  
Weight 32kg  
Code **PW1250**



## WriteOn® revolving whiteboards

Double sided whiteboard that can pivot on its horizontal axis

Enables both sides to be used, or the surface angled towards the audience. Available with coated steel writing surface that has the advantage of accepting magnets, or non-magnetic surface that is one side plain, one side gridded. Sturdy steel frame has 4 castors, 2 of which are locking. Steel cross bars aid rigidity and house the supplied pen tray.



Board Size H 900mm  
W 1200mm  
Laminate **447431**  
Magnetic **447433**



Board Size H 1200mm  
W 900mm  
Laminate **447341**  
Magnetic **447343**



Board Size H 1200mm  
W 1200mm  
Laminate **447441**  
Magnetic **447443**



Sturdy locking wheels



Positive tilt locking lever



Full width pen tray



Board Size H 1200mm  
W 1500mm  
Laminate **447541**  
Magnetic **447543**



Board Size H 1200mm  
W 1800mm  
Laminate **447641**  
Magnetic **447643**





# WriteAngle® revolving whiteboards

Versatile mobile whiteboard with dual action pivoting board

Enables both sides of the board to be used and angled towards your audience. Can be fixed during assembly to pivot either vertically or horizontally to suit your requirement. Available with drywipe steel surfaces to accept magnets or laminate surfaces, one plain and the reverse with a faint grid. Locking castors. Optional flip pad clips available.



Board Size H 900mm  
W 1200mm  
Laminate **448431**  
Magnetic **448433**

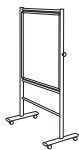

Board Size H 1200mm  
W 900mm  
Laminate **448341**  
Magnetic **448343**



Board Size H 1200mm  
W 1200mm  
Laminate **448441**  
Magnetic **448443**



FOR DRYWIPE ACCESSORIES - SEE PAGES 89 - 92



Board Size H 1200mm  
W 1500mm  
Laminate **448541**  
Magnetic **448543**

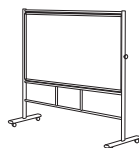

Board Size H 1200mm  
W 1800mm  
Laminate **448641**  
Magnetic **448643**

Flip pad clips  
Pair **WBPC100**



# WriteOn® Whiteboards - Mobile



MWB43



MWB64

## WriteOn® height adjustable mobile whiteboards

Double sided mobile drywipe whiteboard panels

Framed in anodised aluminium and mounted on sturdy white frame with locking castors. These height adjustable panels can be mounted in either portrait or landscape formats. This double sided whiteboard features one side plain and the reverse with a faint Guideline® grid to aid writing.



FOR PINNABLE VERSIONS - SEE PAGE 60

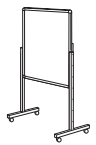

Board Size H 1200mm  
W 900mm  
Whiteboard **MWB43**

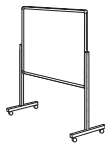

Board Size H 1200mm  
W 1200mm  
Whiteboard **MWB44**



Board Size H 1500mm  
W 1200mm  
Whiteboard **MWB54**



Board Size H 1800mm  
W 1200mm  
Whiteboard **MWB64**

## WriteOn® wood framed mobile whiteboards

A range of handmade beech framed boards

Double sided drywipe whiteboards available in 3 sizes. Features one side plain and the reverse with a faint Guideline® grid to aid writing. Heavy duty frame, made from quality lacquered beech sourced from sustainable forests. Edges of the board are rounded for increased safety. Heavy duty wooden feet ensure stability when free standing; wheels are provided if mobility is required.

Pinnable option in Red or Blue loop nylon is also available for all 3 sizes - see page 61.



DJS44/WB



Size H 1200mm  
W 1200mm  
Whiteboard **DJS44/WB**

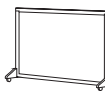

Size H 1200mm  
W 1800mm  
Whiteboard **DJS46/WB**

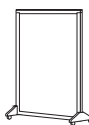

Size H 1800mm  
W 1200mm  
Whiteboard **DJS64/WB**

## WriteOn® drywipe foyer boards



### Stand mounted angled foyer whiteboard

A drywipe whiteboard mounted portrait on an angled simple stand, ideal for displaying hand written information in foyer and reception areas. White powder coated stand and mounted 900 x 600mm whiteboard with a finished height of 1800mm.

Board Size H 900mm  
W 600mm  
Stand Height 1800mm  
Code **FWB32**



SFW015/BL

## Shield® drywipe foyer boards

Frame colours - see page 64



Aluminium Blue Green Red White Black



Board Size H 600mm  
W 450mm  
Stand Height 1000mm  
Code **SFW005**



Board Size H 900mm  
W 600mm  
Stand Height 1000mm  
Code **SFW015**

Deluxe framed whiteboard on a contemporary heavy duty stand

This freestanding whiteboard has an adjustable bracket to enable the board to be mounted perpendicular or up to 45° angle. Board can be mounted landscape or portrait.

### TO ORDER:

Please state the product code followed by the frame colour code required.

EXAMPLE: 900 x 600mm with blue frame = **SFW015/BL**

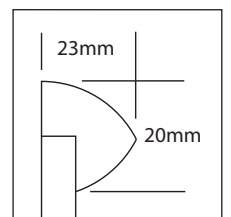

# WriteOn® Whiteboards - Printed



46816

## WriteOn® printed modular whiteboards

### Printed whiteboards that mount flush side by side

A range of printed whiteboards edged with 2mm low profile white edging. This frameless design enables the boards to be mounted side by side, almost seamlessly. The non-magnetic ultra smooth boards are 1200mm x 1200mm and supplied with wall fixings. Available lined, gridded, handwriting lines, music staves or plain. Wall fixings supplied.

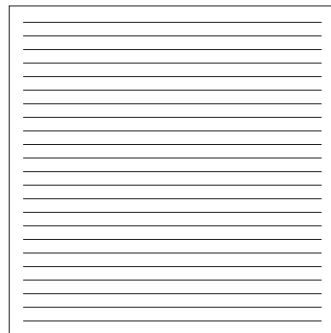

**50mm lined**  
Size H 1200mm  
W 1200mm  
Code **46813**

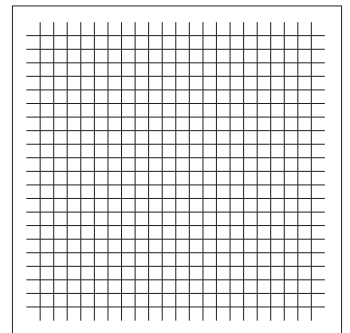

**50 x 50mm gridded**  
Size H 1200mm  
W 1200mm  
Code **46814**

46814



49344



Please note these boards are frameless so sizes shown are nominal

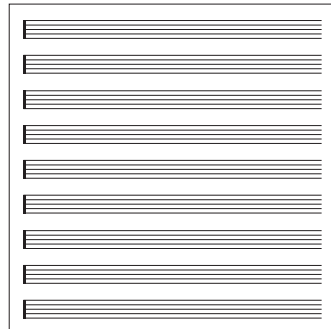

**Music staves**  
Size H 1200mm  
W 1200mm  
Code **46815**

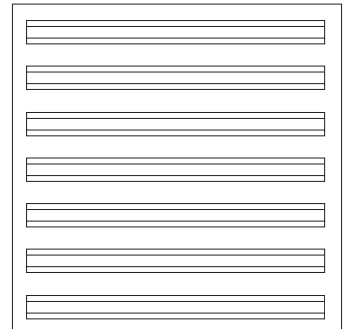

**Handwriting**  
Size H 1200mm  
W 1200mm  
Code **46816**



**Plain**  
Size H 1200mm  
W 1200mm  
Code **49344/WH**

## Timeminder® in-out personnel message whiteboard

Simple In-Out and message board for 20 people

This simple printed drywipe board will show your staff's whereabouts and also has space for messages. 600 x 450mm blue edged drywipe board. Simple through the board fixings supplied with discreet white cover caps.

Size H 600mm  
W 450mm  
Code **46836**

Names	In	Out	Messages
John	X		
Stephen		X	
Jackie		X	Phone Robert
Robert		X	
Colin	X		
Sarah B	X		
Abigail	X		
Toby	X		
Christine			DCM called
Sarah F	X		
Graham		X	



## WriteOn® magnetic UK county map

Simple county boundary map of the UK and Ireland

This useful map has been stripped down to show the minimum of information - often required for regional planning activities. Shows county boundaries and county names only. Drywipe steel surface accepts magnets. All fixings supplied.

Size H 1200mm  
W 900mm  
Code **46840**



46842

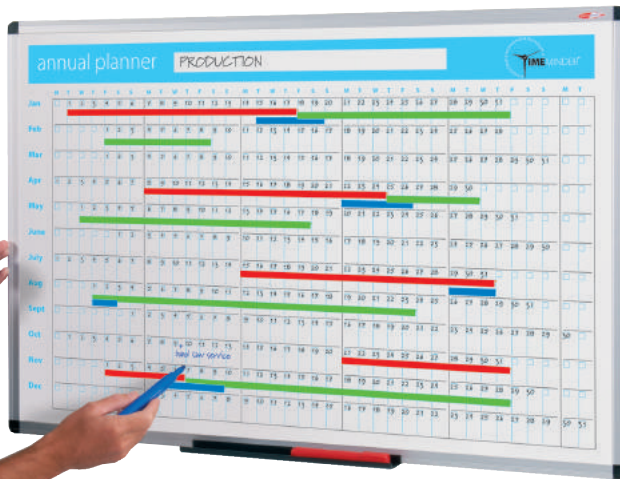

## Timeminder® drywipe perpetual planners

Undated planners that can be used time and time again

Useful range of printed whiteboard planners available in 5 variants to suit your needs, each in a choice of 2 whiteboard styles.

### Aluminium framed

Drywipe coated steel version to accept magnets. Supplied with through the corner fixings and pen tray. For magnetic accessories see page 91 - 92.

### Blue edged frameless design

Drywipe laminate non-magnetic surface for use with drywipe pens. This sleek modern design is supplied with through the board fixings, white caps conceal fixing.

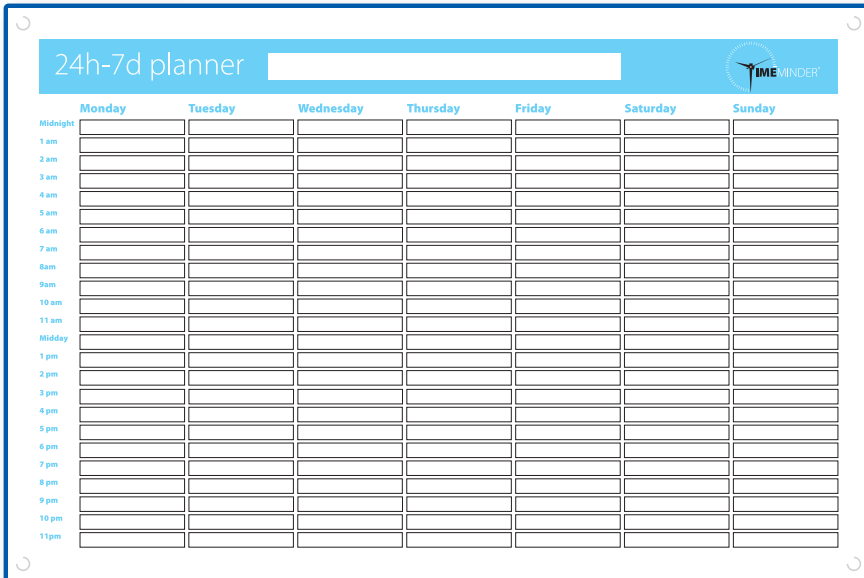

### 24 hour -7 day planner

Size H 600mm  
W 900mm

Blue colour edged  
Non magnetic **46831**

Aluminium framed  
Magnetic **46841**

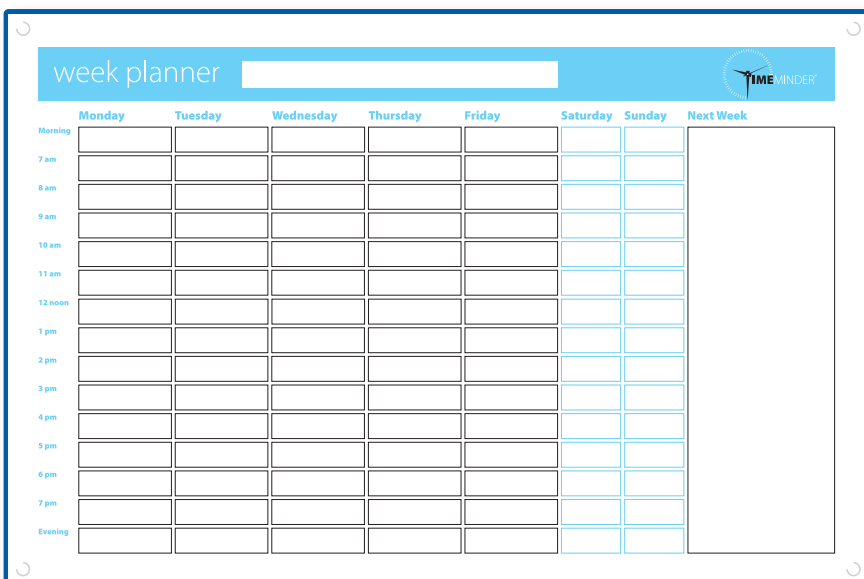

### Week planner

Size H 600mm  
W 900mm

Blue colour edged  
Non magnetic **46834**

Aluminium framed  
Magnetic **46844**



Blue colour edged



Aluminium framed magnetic



Blue colour edged



Aluminium framed magnetic

**Appointments planner**

Size H 600mm  
W 900mm

Blue colour edged  
Non magnetic **46835**

Aluminium framed  
Magnetic **46845**

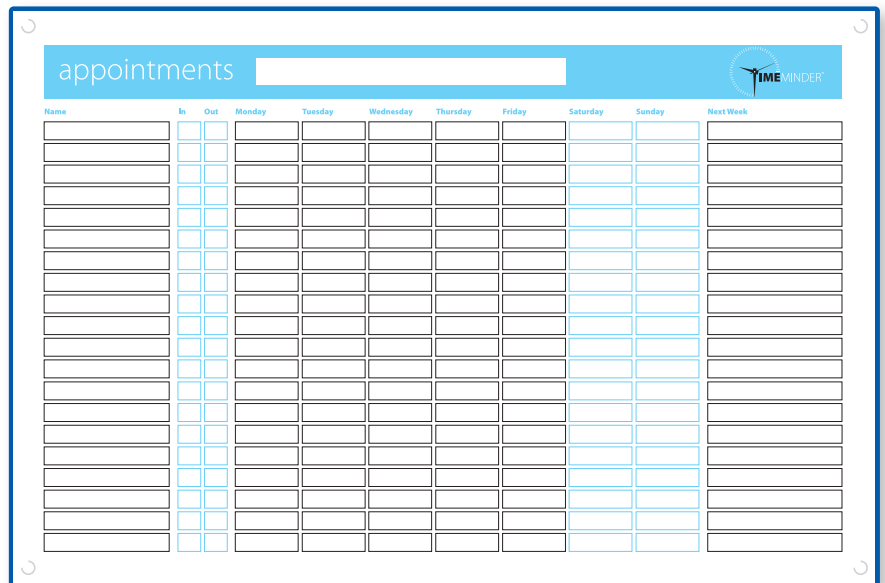

**Month planner**

Size H 600mm  
W 900mm

Blue colour edged  
Non magnetic **46833**

Aluminium framed  
Magnetic **46843**

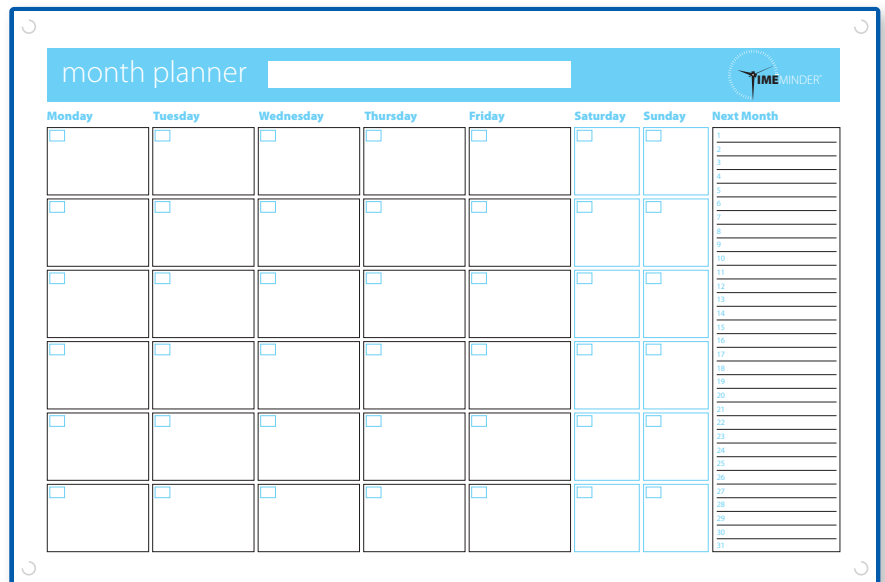

**Annual planner**

Size H 600mm  
W 900mm

Blue colour edged  
Non magnetic **46832**

Aluminium framed  
Magnetic **46842**

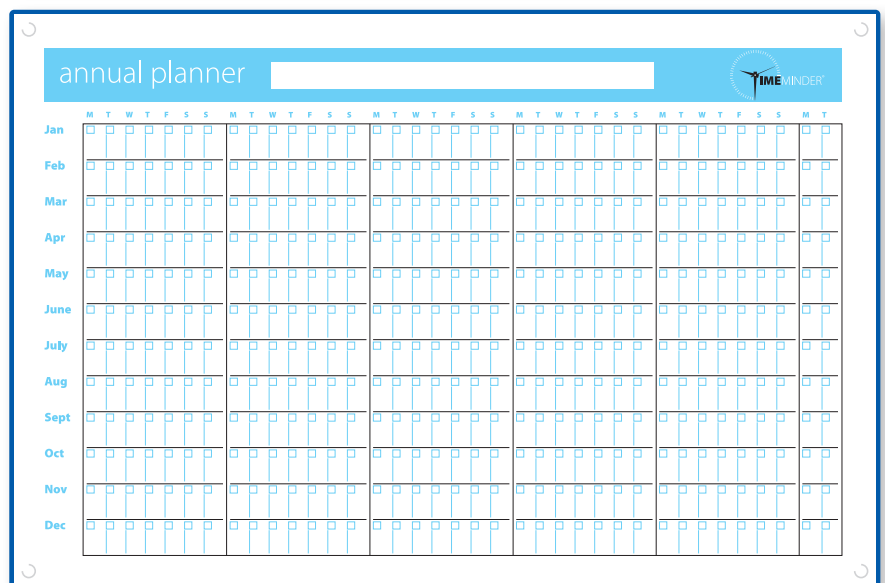

## WriteOn® tactical sportsboards

Great aid for teaching team sports

Popular range of drywipe sportsboards printed with the pitch layout of popular sports including Football, Rugby Union, Hockey, Basketball, Cricket and Netball.

The 1200 x 900mm aluminium framed whiteboards accept magnets and are supplied with pen tray and wall fixings. A wide range of accessories are available for marking up the boards, including a convenient pack of 20 coloured magnetic disks.



46806

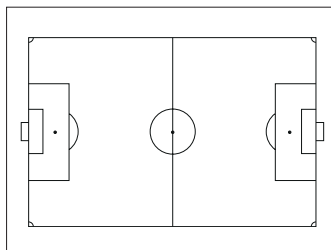

### Football

Size H 900mm  
W 1200mm

Code **46806**

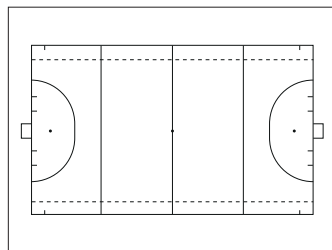

### Hockey

Size H 900mm  
W 1200mm

Code **46807**

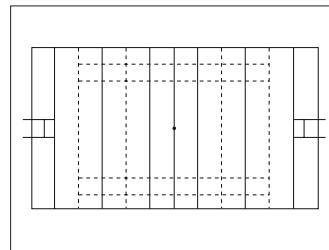

### Rugby league

Size H 900mm  
W 1200mm

Code **46808**

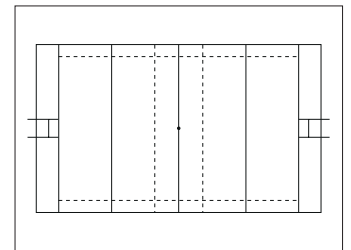

### Rugby union

Size H 900mm  
W 1200mm

Code **46809**

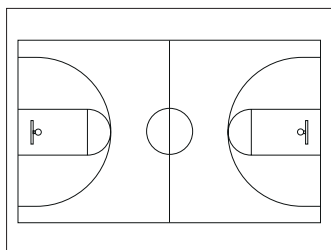

### Basketball

Size H 900mm  
W 1200mm

Wall **46810**

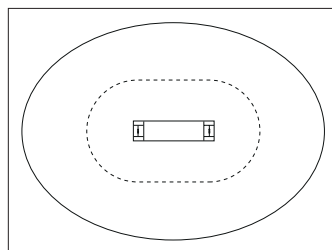

### Cricket

Size H 900mm  
W 1200mm

Code **46811**

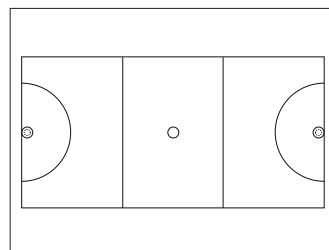

### Netball

Size H 900mm  
W 1200mm

Code **46812**



30mm dia. magnets  
20 x Red **439153X2**  
20 x Blue **439154X2**



## WriteOn® handheld tactical sportsboards

### New range of A3 sized drywipe sportsboards

Handy for demonstrating tactics on the sideline. Pitches and courts are illustrated for the UK's most popular team sports; Football, Rugby League, Rugby Union, Hockey, Cricket, Basketball and Netball. Sturdy but lightweight A3 size boards have easy clean drywipe surface. Sold as singles or packs of 10.

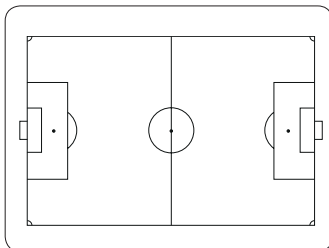

**Football**  
A3 H 297mm  
W 420mm  
Single **SB1**  
Pack of 10 **SB110**

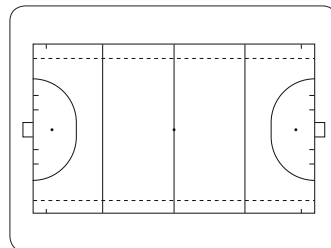

**Hockey**  
A3 H 297mm  
W 420mm  
Single **SB2**  
Pack of 10 **SB210**

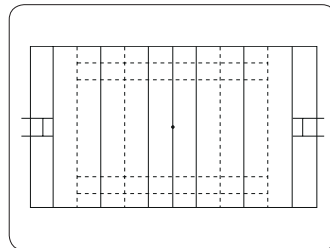

**Rugby league**  
A3 H 297mm  
W 420mm  
Single **SB3**  
Pack of 10 **SB310**

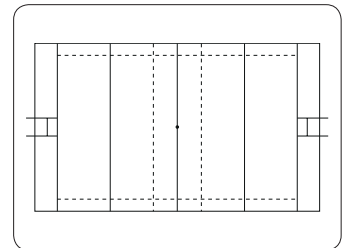

**Rugby union**  
A3 H 297mm  
W 420mm  
Single **SB4**  
Pack of 10 **SB410**

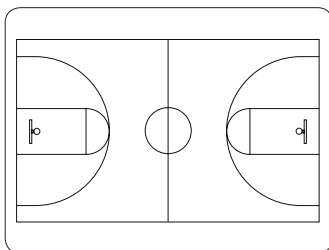

**Basketball**  
A3 H 297mm  
W 420mm  
Single **SB5**  
Pack of 10 **SB510**

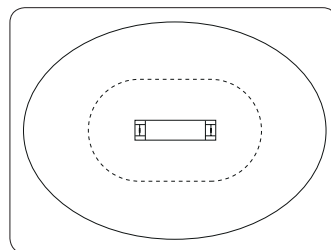

**Cricket**  
A3 H 297mm  
W 420mm  
Single **SB6**  
Pack of 10 **SB610**

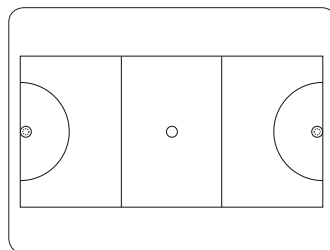

**Netball**  
A3 H 297mm  
W 420mm  
Single **SB7**  
Pack of 10 **SB710**



**Wallet of 4 WriteOn® pens**  
1 of each Black, Blue, Red, Green  
Assorted **439115**



## WriteOn® framed drywipe maps

Framed drywipe maps that accept magnets

Mounted and framed maps with a drywipe surface suitable for use with dry erase pens with the advantage of accepting magnets. Choose from World map, European map, UK Postcode, UK road and terrain and UK county boundary. Supplied with wall fixings.

World  
 Size H 1020mm  
 W 1460mm  
 Code **439166**



### UK county boundary

Size H 1140mm  
 W 950mm  
 Code **439170**

### UK road and terrain

Size H 1140mm  
 W 950mm  
 Code **439169**

### UK postcode

Size H 875mm  
 W 630mm  
 Code **439168**

### European

Size H 1280mm  
 W 1020mm  
 Code **439167**





## WriteOn® drywipe pen with NEW ink formula

New ink formula is now glassboard compatible

These pens are ideal for all standard whiteboards and now, due to a new ink formula, can also be used on glassboards. Quick drying, low odour and non-toxic. 6mm bullet tip. Also non-bleed on flip pad paper.



## Dry/wetwipe glass and blackboard pens

Vibrant coloured pens with 9mm chisel tip.

Designed to dry-wipe from glass or wet-wipe from chalkboard surfaces. Allow to dry before attempting to erase. Pack of 3 white pens or pack of 5 assorted colours - Red, Yellow, Pink, Green and Orange.

Pack of 3 white pens  
Code **439501**

Pack of 5 assorted pens  
Code **439500**

Wallet of 4 pens  
1 of each Black, Blue,  
Red, Green  
Code **439115**

Box of 10 pens  
3 x Black, 3 x Red,  
2 x Blue, 2 x Green  
Code **439116**



## Wetwipe glass and blackboard narrow tip pens

Coloured

These pens are for use on glass or chalkboard surfaces. They have a 3mm chisel tip. Once dry, the ink can be removed with a wet cloth. Packs of 5 assorted colours - Black, Red, Blue, Green and Yellow.

Pack of 5 assorted pens  
Code **539100**

White

These pens are for use on glass or chalkboard surfaces. They have a 3mm chisel tip. Once dry, the ink can be removed with a wet cloth. Packs of 5 white pens.

Pack of 5 white pens  
Code **539101**

## Glass whiteboard and blackboard cleaner

A 250ml pump action spray cleaner for refreshing boards periodically. Will also remove stubborn stains from porous surfaces. Handle with care - read instructions before use.

250ml bottle  
Code **539102**

# WriteOn® Whiteboards - Accessories



## Whiteboard spray cleaner

Formulated cleaning fluid for removing stubborn marks and ghosting. Suitable for laminate, coated steel or VES whiteboards. Recommended for use with Drywipes.

250ml **439163**



## Whiteboard wet and dry wipes

### Wet Wipes

Resealable tub of 50 wipes pre-impregnated with formulated whiteboard cleaning fluid.

### Dry Wipes

Convenient resealable tub of 100 tear off drywipes for use with spray cleaners.

50 Wet Wipes **439161**  
100 Dry Wipes **439162**



## Whiteboard cleaning kit

Special formula solvent free board cleaner and drywipes supplied in a convenient holder. Supplied with magnetic and adhesive mounting strips.

Code **439160**



## Whiteboard starter kit

This kit contains the basic items you need to get going. Three pens in blue, red and black plus an eraser; together with a spray cleaner and pack of drywipes.

Code **439177**



## Whiteboard survival kit

All the essentials to keep your board in tip-top condition. The kit includes Wetwipes, Cleaning spray, Drywipes, a professional eraser and 6 pens. Pen holder is supplied with magnetic and adhesive fixing strips to mount on any style of board.

Code **439178**



## Whiteboard erasers

### Economy magnetic eraser - Pack of 3

Low cost lightweight eraser supplied in a pack of three.

### Professional eraser

With 10 peel off faces that gives you a new cleaning surface each time.

Economy **439165**

Professional **439164**

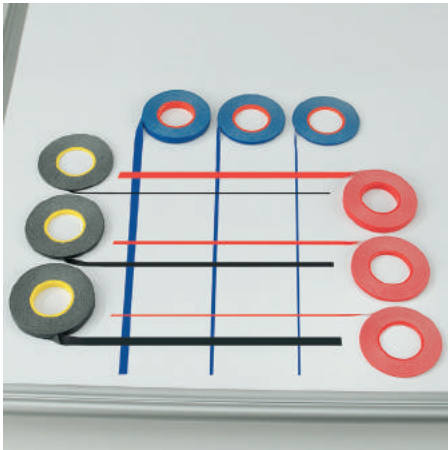

## Whiteboard gridding tape

Useful low profile tape for creating lines, grids or tables on a whiteboard surface. Available in red, blue, green and black; and 1.5mm, 3mm and 6mm widths. Supplied on 16m role.

	1.5mm	3mm	6mm
Width			
Black	<b>439300</b>	<b>439304</b>	<b>439308</b>
Red	<b>439301</b>	<b>439305</b>	<b>439309</b>
Blue	<b>439302</b>	<b>439306</b>	<b>439310</b>
Green	<b>439303</b>	<b>439307</b>	<b>439311</b>

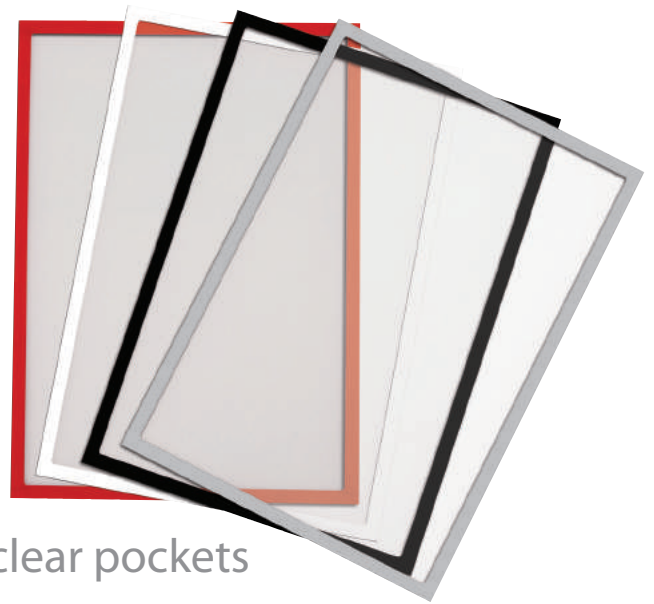

## A4 magnetic clear pockets

Magnetic anti-glare PET pockets are ideal for displaying A4 sized printed materials on VES or coated steel white boards. Available in 4 popular colours and 3 pack sizes to suit your requirements.



	Each	Pack of 5	Pack of 10
Red	<b>43990R</b>	Red <b>43991R</b>	Red <b>43992R</b>
White	<b>43990W</b>	White <b>43991W</b>	White <b>43992W</b>
Black	<b>43990B</b>	Black <b>43991B</b>	Black <b>43992B</b>
Grey	<b>43990G</b>	Grey <b>43991G</b>	Grey <b>43992G</b>



## Flipchart clips

A pair of clips designed to hang A1 flip pads. Specifically designed to fit on WriteOn® mobile whiteboards - see pages 79 - 80.

1 Pair **WBPC100**



## Whiteboard pen holder

Drywipe pens are best stored horizontally as it prevents the tip from drying out. The holder is supplied with four pens and is supplied with magnetic and adhesive mounting strips.

Code **439159**



## Whiteboard accessory kit

Ideal for use with any laminate whiteboard. 2 self adhesive steel disks and 25mm magnets for holding paper plus a self adhesive pen holder (pen not included).

Code **439201**

# WriteOn® Whiteboards - Accessories

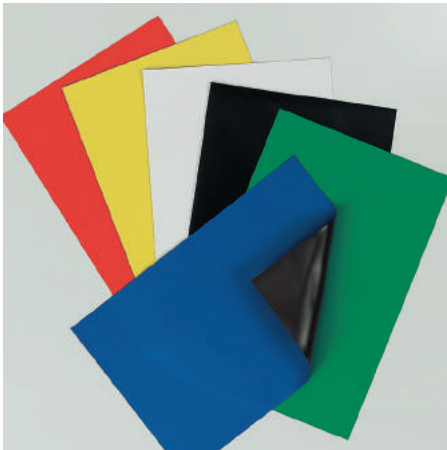

## Magnetic sheets

These colourful A4 magnetic sheets can be cut or guillotined into any shape to suit your application. Ideal for colour coding, heading strips and even planning or organisational charts. Black, Red, Blue, Green, Yellow and White. A4 magnetic sheets are easy to trim to any shape. Durable material.

Black	<b>439137</b>
Red	<b>439138</b>
Blue	<b>439139</b>
Green	<b>439140</b>
Yellow	<b>439141</b>
White	<b>439142</b>



## Magnetic tape

Rolls of brightly coloured magnetic tape that enable you to create temporary gridding and lines on a steel whiteboard. Can also be used for simple paper and memo hanging on a steel surface such as filing cabinets. Black, Red, Blue, Green, Yellow and White. Supplied in 5m rolls by 10mm wide.

Black	<b>439131</b>
Red	<b>439132</b>
Blue	<b>439133</b>
Green	<b>439134</b>
Yellow	<b>439135</b>
White	<b>439136</b>



## Coloured magnets

A range of colourful magnets available in different sizes to suit your application. Supplied in packs of 10 in a variety of colours. The ergonomically designed outer disk makes the magnet easy to lift and reposition.

Diameter	20mm	30mm
Black	<b>439147</b>	<b>439152</b>
Red	<b>439148</b>	<b>439153</b>
Blue	<b>439149</b>	<b>439154</b>
Green	<b>439150</b>	<b>439155</b>
Assorted	<b>439151</b>	<b>439156</b>



## Magnetic shapes

Magnetic shapes have been used for many years as a visual aid in project and production planning, training applications etc. Each sheet has 81 die cut shapes of various sizes including arrows, squares, circles and triangles. Black, White, Blue, Green, Red and Yellow sheet measures 150 x 150mm.

Pack of 6	<b>439130</b>
assorted colours	



## Magnetic characters

Magnetic letters and numbers can be used for a multitude of uses around any work place. Use to create simple signage, headers on white boards, and even to create your own in-out board. Square cut letters for simple alignment. A4 sheet with 23mm or 43mm high characters.

Height	23mm	43mm
Letters	<b>439143</b>	<b>439145</b>
Numbers	<b>439144</b>	<b>439146</b>



## Super strength magnets

These high power neodymium magnets have Herculean strength for their size. Ideal for affixing heavier material. 25mm magnets can also be used on glass whiteboards - see pages 75 and 117. Available in two sizes, 16mm and 25mm diameter in a striking machined look finish. The disk has sizeable ridges to assist in lifting or relocating magnets.

Diameter	16mm	25mm
Pack of 5	<b>439157</b>	
Pack of 2		<b>439158</b>

# Flipchart Easels and Rail Systems

- 94 Tripod Easels
- 95 Mobile Easels
- 96 - 97 Coloured Ultimate Easels
- 98 Conference Pro Easel
- 99 Combi Mobile Easel
- 100 - 101 BusyRail®
- 102 Trapease Flipchart Hanger
- 102 Flipchart Accessories



# Flipchart Easels - Tripod



## Cygnet magnetic flipchart easel

An entry level tripod easel but with the features of a more expensive model

Aluminium frame with steel drywipe surface to accept magnets. Adjustable flip pad holders. Rear leg has a brace for increased stability. Supplied with clip-on pen tray.

Clip on pad clamp



Pen tray



Leg brace for stability



Board Size	H 1000mm
	W 680mm
Max height	1850mm
Weight	8kg
Easel	<b>443000</b>



## Hawk magnetic flipchart easels

Tripod easel with class beating features

Rear leg tie bar for extra stability and durability and telescopic legs that allow simple height adjustment. Magnetic drywipe surface is 1000 x 680mm and has curved pen tray to base. Hinged pad clamp with hangers for standard pre-drilled A1 flip pads. Available with black or white framework.

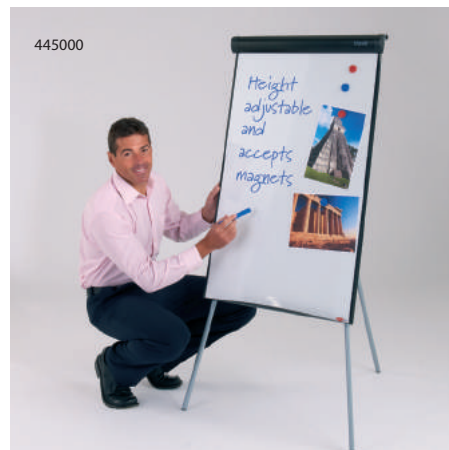

Board Size	H 1000mm
	W 680mm
Max Height	1850mm
Weight	10kg
Black	<b>445000</b>
White	<b>445001</b>

445000



445001



Leg brace for stability







## Buzzard mobile flipchart easel

Mobile flipchart easel mounted on a five star base with locking castors

Metal pad clamp with hangers to take all standard A1 flipchart pads. Magnetic whiteboard is height adjustable with spring loaded assist. Two side arms are supplied as standard for hanging completed sheets. Full width pen tray.

Board Size	H	1000mm
	W	680mm
Max Height		1900mm
Weight		14kg
Code		<b>449505</b>

Height adjustable



# Flipchart Easels - Coloured



## Ultimate loop leg flipchart easel

Top selling colour framed easel - now in 6 colours

Loop leg design creates very steady base and foot bar aids stability when writing. Double sided magnetic whiteboard can be angled flat to aid pad preparation and is fully height adjustable. Available framed in a choice of 6 colours. Suitable for A1 standard 2 hole drilled pads. Optional carry bag.

Board Size	H	860mm
	W	650mm
Max Height		1720mm
Weight		7.15kg
Blue		<b>448084</b>
Red		<b>448082</b>
Green		<b>448085</b>
Black		<b>448081</b>
Grey		<b>443001</b>
White		<b>448086</b>
Carry bag		<b>448083</b>

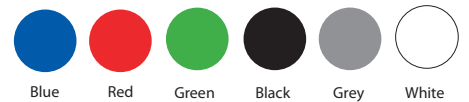

Range of 6 colour options



Optional carrying bag



Tilts for preparation

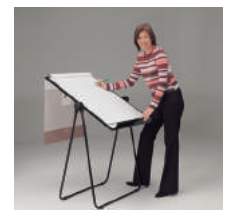

FOR FLIPCHART WALL HANGER - SEE PAGE 102

## Ultimate mobile flipchart easel

New heavy duty mobile Ultimate easel - now in 6 colours

The mobile version of our bestselling Ultimate easel. The large magnetic whiteboard is mounted on a height adjustable column and round tubular steel base with locking castors. Maximum height 1900mm. Available in a choice of 6 colours. Features integrated pen tray. Suitable for use with standard A1 predrilled pads.

Board Size	H 1000mm
	W 680mm
Max Height	1900mm
Weight	15kg
Blue	<b>449603</b>
Red	<b>449602</b>
Green	<b>449604</b>
Black	<b>449601</b>
Grey	<b>449605</b>
White	<b>449606</b>

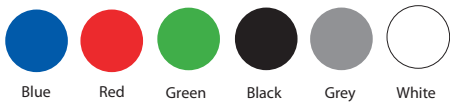

Pad hangers



Integrated pen tray



Locking castors



Simple height adjustment



FOR FLIPCHART PADS AND PENS - SEE PAGE 102

**New Design**

**Write on**



449603



# Flipchart Easels - Portable



## Conference pro flipchart easel

Premier feature packed easel - the best on the market

High quality flipchart easel with large 1000 x 700mm coated steel writing surface that also accept magnets. Fully height adjustable board from seated position to standing height of 1920mm. Legs interlock to assist carrying and even have wheels for mobility. Integral side arm with paper clips can be mounted to left or right, for hanging completed sheets. Robust yet lightweight aluminium construction. **3 year guarantee.**

Board Size H 1000mm  
W 700mm  
Height adjustment 1250-1920mm  
Weight 11kg  
Easel **463770**



Integrated ... pen shelf



...carrying handle



...wheels for mobility



Easy height adjustment





## Combi mobile information board

Freestanding board with whiteboard one side, noticeboard on reverse

A versatile mobile board offering both pinboard and whiteboard applications in one product. Height adjustable. Whiteboard surface also accepts magnets. Available in two popular sizes and mounted on a stable powder coated steel frame, with four castors two of which are lockable. A1 flip pad clamp on all whiteboard surfaces.

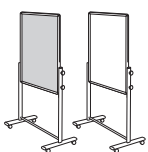

Board Size H 1200mm  
W 700mm  
Code **448050**

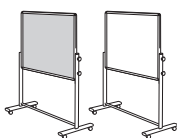

Board Size H 1000mm  
W 1000mm  
Code **448051**



# Rail Systems - BusyRail®



## BusyRail® Deluxe

Our premium quality rail system is packed with user friendly features and is consistently specified where aesthetic appeal and long term durability are essentials

All suspended equipment locates securely on the rail, yet glides effortlessly when required. Whiteboard and noticeboard products have the additional benefit of small guide wheels attached at the lower edge for even greater mobility. Hanging components are adaptable for use with Mono-glide or Dual-glide rail. The recommended installation height for rail is approx. 2000 - 2100mm from the floor (or in line with the top of the door frame).

Both Mono-glide and Dual-glide rails are manufactured from strong extrusion and all components hang and glide effortlessly. Both rails also have an ingenious integral paper hanging facility - ideal for those brainstorming sessions. Both rails are supplied in 240cm lengths complete with all fixings and end caps. Both rails have optional moulded corner pieces which are radiused so that equipment can easily be moved round and across inside corners - a facility unique to this rail system. Can be easily installed with modest DIY skills.



### Mono-Glide

A single rail - suitable for simple installations.

### Dual-Glide

Ideal in the movement of multiple equipment around larger rooms. Larger items such as screens and flipcharts can be moved effortlessly over the top of whiteboards and noticeboards without removing them from the wall.

### Monoglide

Size L 2400mm  
Rail **BR1000**  
Corner Piece **BR1001**

### Dualglide

Size L 2400mm  
Rail **BR1020**  
Corner Piece **BR1021**

### Felt noticeboards

Comprehensive range of noticeboards include 3 sizes in 3 felt colours. Felt covered boards accept loop nylon fasteners as well as pins.

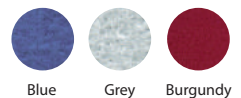

Size	H 600mm W 900mm	Size	H 900mm W 1200mm	Size	H 900mm W 1800mm
Blue	<b>BR1009/BL</b>	Blue	<b>BR1010/BL</b>	Blue	<b>BR1011/BL</b>
Grey	<b>BR1009/GY</b>	Grey	<b>BR1010/GY</b>	Grey	<b>BR1011/GY</b>
Burgundy	<b>BR1009/BU</b>	Burgundy	<b>BR1010/BU</b>	Burgundy	<b>BR1011/BU</b>



**Magnetic Whiteboards**

Top quality steel whiteboard surface, accepts magnets as well as dry-wipe markers. Supplied complete with a useful pen tray. Available in 3 standard sizes.

Size	H 600mm	Size	H 900mm
	W 900mm		W 1200mm
Code	<b>BR1006</b>	Code	<b>BR1007</b>



**Projection Screens**

Integral struts are incorporated into the design to allow adjustment of the screen angle. Supplied ready assembled. Perfectly flat rigid board surface. Available in 3 standard sizes. Video format versions available upon request.

Size	H 900mm	Size	H 1250mm	Size	H 1500mm	Size	H 1800mm
	W 1800mm		W 1250mm		W 1500mm		W 1800mm
Code	<b>BR1008</b>	Code	<b>BR1014</b>	Code	<b>BR1015</b>	Code	<b>BR1022</b>



**Flipchart Easel**

Stylish flipchart easel features a quick release flip pad clamp and a whiteboard surface that accepts magnets as well as dry-wipe markers. Fully adjustable clamp accepts any pre-drilled 2 hole A1 flip pad. Incorporates a useful pen tray.

Code	<b>BR1002</b>
------	---------------



**Shelving Units**

Sturdy shelving units that securely hold TV and DVDs or narrower shelved units for book storage. Both shelving units have 2 shelves, upper shelf being height adjustable. Substantial white frame with grey shelves. Max. combined weight for both shelves - 25kg.

Shelf Size	W 790mm	Shelf Size	W 790mm
	D 500mm		D 300mm
TV Shelf	<b>BR1016</b>	Book Shelf	<b>BR1017</b>



**Leaflet Dispenser**

Ideal for housing brochures, information packs etc. in a training room environment. 10 clear A4 acrylic pockets mounted on a backing board.

10 Pocket	<b>BR1018</b>
-----------	---------------



Picture hooks	
Pack of 4	<b>BR1019</b>

# Flipchart Easels - Accessories



## Trapeze® paper hanging system

Ingenious rail for hanging paper or card

Trapeze is so simple to use, simply insert a sheet of paper and it is held in place with specially designed rollers. Lift the sheet of paper and it is released. Ideal for training rooms, brainstorming sessions, hanging artwork, maps and charts. Various thicknesses of material can be held even side by side. Available in three standard lengths, and can be butted end to end to create longer runs. Easy snap fit or adhesive strip mounting. Can be adapted to be an all white system.



**600mm**  
 Size H 54mm  
 W 600mm  
 D 22mm  
 Code **TE060**



**1200mm**  
 Size H 54mm  
 W 1200mm  
 D 22mm  
 Code **TE120**



**1800mm**  
 Size H 54mm  
 W 1800mm  
 D 22mm  
 Code **TE180**

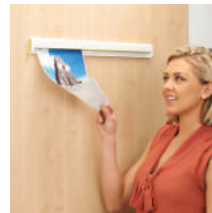

## Flipchart pads

Ideal for easels and mobile whiteboards.

40 sheet pad with perforated top, supplied in a pack of 5.  
 70gsm recycled bleedproof paper for use with flipchart pens.

- 5 pack **450010**
- 5 packs of 5 **450010/5**
- 10 packs of 5 **450010/10**
- 20 packs of 5 **450010/20**



## WriteOn® drywipe and flipchart pens

The presenters pen for both drywipe and flipchart use

Specially designed for use on both drywipe whiteboards, glassboards and flipchart pads. Available in four colours packed in a wallet of 4 or boxed in 10's. Quick drying non-toxic and low odour formula. 6mm bullet point for excellent definition.

**Wallet of 4 pens**  
 1 of each Black, Blue, Red, Green  
 Code **439115**

**Box of 10 pens**  
 3 x Black, 3 x Red  
 2 x Blue, 2 x Green  
 Code **439116**





# Poster Display and Signage Systems

- 104 - 109 Wall Mounted Poster Display
- 110- 114 Freestanding Poster Display
- 114 - 115 Freestanding WriteOn® Signage
- 116 - 117 Wall Mounted WriteOn® Signage
- 118 WriteOn® Whiteboard Stands
- 118 - 119 In-Out Boards
- 120 Desk Top Signage
- 120 - 124 Wall Mounted Signage



# Poster Display - Wall mounted

Busygrip poster frames B2



## BusyGrip® aluminium poster frames

### Anodised aluminium snap frame

Wide range of popular sized poster frames finished in satin anodised aluminium. The 25mm wide frames simply snap open and closed to change the poster. Poster is protected by anti glare UV resistant cover. Designed for internal use, please see page 66 for external poster frames. Mount portrait or landscape with fixings provided. Available in 7 sizes to take all 'A' sized posters between A4 and A0 plus the most popular 'B' sized posters.



Size A4 H 297mm  
W 210mm  
Profile 25mm  
Code **PFA4AL**

Size A3 H 420mm  
W 297mm  
Profile 25mm  
Code **PFA3AL**

Size A2 H 594mm  
W 420mm  
Profile 25mm  
Code **PFA2AL**

Size A1 H 840mm  
W 594mm  
Profile 25mm  
Code **PFA1AL**

Size A0 H 1189mm  
W 840mm  
Profile 25mm  
Code **PFA0AL**



Size B2 H 700mm  
W 500mm  
Profile 25mm  
Code **PFB2AL**

Size B1 H 1000mm  
W 700mm  
Profile 25mm  
Code **PFB1AL**

Please add 50mm to the dimensions given for the external measurements of the poster frame

### Busygrip poster frames A4



## BusyGrip® coloured poster frames

Distinctive snap frame in a choice of 5 colours

Brightly coloured aluminium poster frames are ideal for mounting posters and notices; such as health and safety, mandatory, and first aid. The 25mm wide frames simply snap open and closed to change the poster. Available in 7 sizes to take all 'A' sized posters between A4 and A0 plus the most popular 'B' sized posters. Choose from vibrant blue, red, green, cool white or black.

**TO ORDER:**

Please state the product code followed by the frame colour code required

EXAMPLE: A4 297 x 210mm with red frame = **PFA4/RD**

**Frame colours**



Busygrip poster frames A4 PFA4/RD



Size A4 H 297mm  
W 210mm  
Profile 25mm  
Code **PFA4**



Size A3 H 420mm  
W 297mm  
Profile 25mm  
Code **PFA3**



Size A2 H 594mm  
W 420mm  
Profile 25mm  
Code **PFA2**



Size A1 H 840mm  
W 594mm  
Profile 25mm  
Code **PFA1**



Size A0 H 1189mm  
W 840mm  
Profile 25mm  
Code **PFA0**



Size B2 H 700mm  
W 500mm  
Profile 25mm  
Code **PFB2**



Size B1 H 1000mm  
W 700mm  
Profile 25mm  
Code **PFB1**

Please add 50mm to the dimensions given for the external measurements of the poster frame

Blue



Green

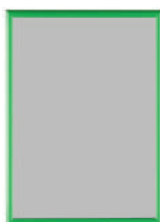

Red

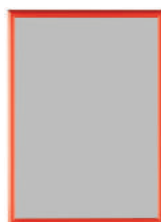

White



Black



# Poster Display - Wall mounted



Busygrip Stainless Steel A4 poster frames PFA4SS



Busygrip Wood A3 poster frames PFA3WD

## BusyGrip® stainless steel poster frames

### Distinctive stainless steel look snap frame

Wide range of popular sized poster frames finished in stainless steel effect aluminium. The 25mm wide frames simply snap open and closed to change the poster. Poster is protected by anti glare UV resistant cover. Mount portrait or landscape with fixings provided. Available in 7 sizes to take all 'A' sized posters between A4 and A0 plus the popular B1 and B2 sized posters.

## BusyGrip® wood look poster frames

### Wood effect poster frames for the traditional look

These poster frames combine the warm look of wood with the durability of aluminium. The 25mm wide frames simply snap open and closed to change the poster. Available in 7 sizes to take all 'A' sized posters between A4 and A0 plus the most popular 'B' sized posters. Posters are protected by anti-glare UV resistant cover. Mount portrait or landscape with fixings provided.



Size A4 H 297mm  
W 210mm  
Profile 25mm  
Stainless Steel **PFA4SS**  
Wood **PFA4WD**



Size A3 H 420mm  
W 297mm  
Profile 25mm  
Stainless Steel **PFA3SS**  
Wood **PFA3WD**



Size A2 H 594mm  
W 420mm  
Profile 25mm  
Stainless Steel **PFA2SS**  
Wood **PFA2WD**



Size A1 H 840mm  
W 594mm  
Profile 25mm  
Stainless Steel **PFA1SS**  
Wood **PFA1WD**



Size A0 H 1189mm  
W 840mm  
Profile 25mm  
Stainless Steel **PFA0SS**  
Wood **PFA0WD**



Size B2 H 700mm  
W 500mm  
Profile 25mm  
Stainless Steel **PFB2SS**  
Wood **PFB2WD**



Size B1 H 1000mm  
W 700mm  
Profile 25mm  
Stainless Steel **PFB1SS**  
Wood **PFB1WD**

Please add 30mm to the dimensions given for the external measurements of the poster frame

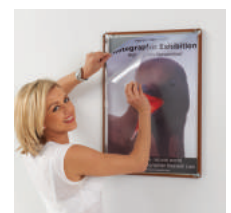
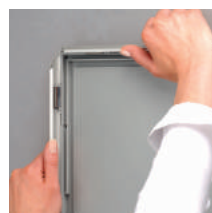

# Wall mounted - Poster Display



Busygrip Certificate frame A4 in Black LD1085



Takes 4 x A4 sheets LD3070

## BusyGrip® certificate frames

Proudly display all A4 certificates on the wall or desk

Available in 3 finishes to suit your environment; natural wood look, contemporary black or traditional anodised aluminium. The frames simply mount to a wall with the fixings supplied or open the integral stand for desktop use. They can be used portrait or landscape for both wall or freestanding. The frames simply snap open and closed to insert or change the certificates which are also protected by anti-glare UV resistant cover.



Wood LD1087

Aluminium LD1086



### Aluminium

Size A4 H 297mm  
W 210mm  
Profile 25mm  
Code **LD1086**

### Wood

Size A4 H 297mm  
W 210mm  
Profile 25mm  
Code **LD1087**

### Black

Size A4 H 297mm  
W 210mm  
Profile 25mm  
Code **LD1085**

## BusyGrip® multiple A4 frames

Designed to house 4, 6 or 9 A4 sheets

Contemporary mix of anodised and black coated aluminium frame enhances the display of multiple A4 sheets. Each A4 sheet is held securely in position with the transparent clip system, no pinning or velcro required. The frames simply snap open and closed to insert or change the sheets as required. Contents are protected by anti-glare UV resistant cover.



Size H 694mm  
W 522mm  
Takes 4 x A4  
Profile 40mm  
Code **LD3070**



Size H 694mm  
W 742mm  
Takes 6 x A4  
Profile 40mm  
Code **LD3071**



Size H 999mm  
W 742mm  
Takes 9 x A4  
Profile 40mm  
Code **LD3072**

# Poster Display - Wall mounted



## Locking poster cases

These weather resistant locking poster cases are designed to take standard paper sizes. Ideal for public information. Clips inside the case hold paper securely. Single lock on 3 smaller sizes, 2 on the rest



Size A4 H 297mm  
W 210mm  
Profile 45mm  
Code **LPC1000**



Size A3 H 420mm  
W 297mm  
Profile 45mm  
Code **LPC1001**



Size A2 H 594mm  
W 420mm  
Profile 45mm  
Code **LPC1002**



Size A1 H 840mm  
W 594mm  
Profile 45mm  
Code **LPC1003**



Size A0 H 1189mm  
W 840mm  
Profile 45mm  
Code **LPC1004**



Size H 700mm  
W 500mm  
Profile 45mm  
Code **LPC1005**



Size H 1000mm  
W 700mm  
Profile 45mm  
Code **LPC1006**

## BusyGrip® external poster cases

Weatherproof and tamperproof design

This snap frame is fitted with a weatherproof seal preventing water damage. The special frame profile and higher strength springs prevent casual tampering as a unique tool is required to open the frame. Supplied with opening tool. UV protective film prevents fading.



Size A4 H 297mm  
W 210mm  
Profile 32mm  
Code **EPF1000**



Size A3 H 420mm  
W 297mm  
Profile 32mm  
Code **EPF1001**



Size A2 H 594mm  
W 420mm  
Profile 32mm  
Code **EPF1002**



Size A1 H 840mm  
W 594mm  
Profile 32mm  
Code **EPF1003**



Size A0 H 1189mm  
W 840mm  
Profile 32mm  
Code **EPF1004**



Size H 700mm  
W 500mm  
Profile 32mm  
Code **EPF1005**



Size H 1000mm  
W 700mm  
Profile 32mm  
Code **EPF1006**

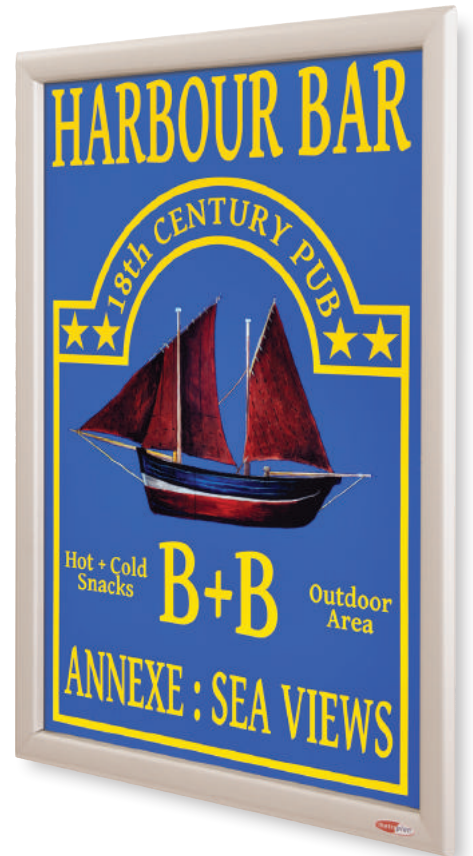

## Shield® Design coloured poster cases

Distinctive poster case with lift off cover

A contemporary alternative to a snap frame, offering the added security of a lockable cover that secures with an allen key. The Shield® contoured frame is available in satin anodised aluminium or in a range of 4 striking powder coated finishes - blue, red, green or white. 5 sizes from A4 to A0 - portrait mounting. Posters secure to black loop nylon backing with Velcro®. Designed for internal use.

**TO ORDER:**

Please state the product code followed by the frame colour code required

EXAMPLE: A2 594 x 420mm with red frame = **SPC1002/RD**

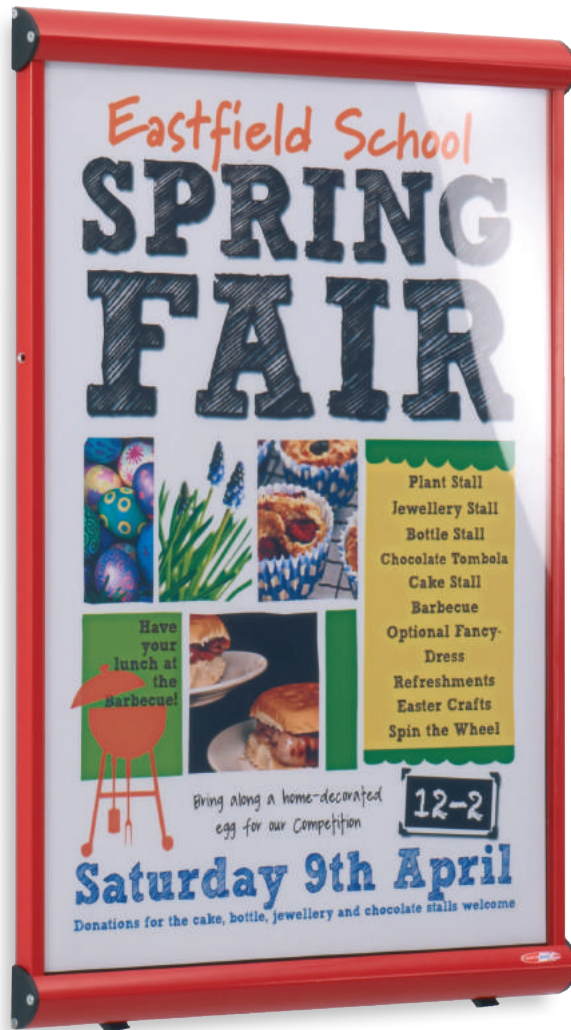

SPC1002/RD

Frame colours - see page 64



Aluminium Blue Green Red White



Size A4 H 297mm  
W 210mm  
External H 365mm  
W 242mm  
Each **SPC1000**



Size A3 H 420mm  
W 297mm  
External H 488mm  
W 329mm  
Each **SPC1001**



Size A2 H 594mm  
W 420mm  
External H 662mm  
W 452mm  
Code **SPC1002**



Size A1 H 840mm  
W 594mm  
External H 908mm  
W 624mm  
Code **SPC1003**



Size A0 H 1189mm  
W 840mm  
External H 1257mm  
W 872mm  
Code **SPC1004**

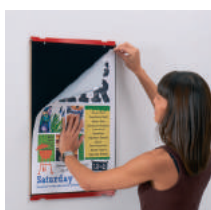
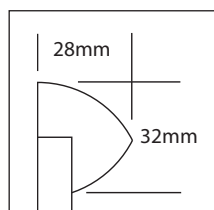

Coloured frames



Aluminium frames

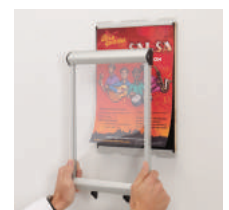

# Poster Display - Freestanding



## BusyGrip® standard information stands

Stylish single height freestanding poster frames which have adjustment for viewing angle and orientation

Aluminium post combines with a sturdy steel base to provide stability. Available in A4 or A3, with satin anodised aluminium snap frames which can be rotated to be used portrait or landscape.



Size A4 H 297mm  
W 210mm  
Height Port. 1010mm  
Height Land. 967mm  
Code **LD1073**

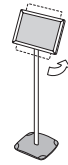

Size A3 H 420mm  
W 297mm  
Height Port. 1076mm  
Height Land. 1014mm  
Code **LD1074**

## BusyGrip® telescopic information stands

Freestanding poster frame which is adjustable in height, angle and orientation

Telescopic aluminium post allows the frame to be height adjustable by 340mm. Available in A4 or A3, with satin anodised aluminium snap frames which can be rotated to be used portrait or landscape. Frames can also be viewed at any angle between horizontal and vertical. Sturdy steel base provides stability.

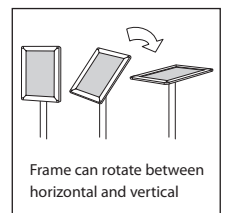

Size A4 H 297mm  
W 210mm  
Height Port. 910-1250mm  
Height Land. 865-1205mm  
Code **LD1071**

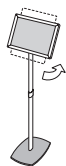

Size A3 H 420mm  
W 297mm  
Height Port. 970-1310mm  
Height Land. 910-1250mm  
Code **LD1072**



## BusyGrip® black poster stands

### Freestanding black poster stand

Attractive curved black stand holds A4 or A3 sized frames to display menus, sales literature or other information. The frame is mounted at the optimum viewing angle and able to be adjusted for horizontal or portrait orientation. The coated curved aluminium post is attached to a stable steel base.



Size A4 H 297mm  
W 210mm  
Height Port. 1212mm  
Height Land. 1176mm  
Code **LD1063**



Size A3 H 420mm  
W 297mm  
Height Port. 1262mm  
Height Land. 1212mm  
Code **LD1064**



## BusyGrip® black illuminated poster stands

### LED edge lit acrylic poster stand in black

These striking curved black stands hold a A4 or A3 sized frame to illuminate menus, sales literature or other information. The frame is mounted at the optimum viewing angle and can be adjusted for horizontal or portrait orientation. The coated curved aluminium post is attached to a stable steel base. Integrated on-off switch at the rear of the unit. CE tested, comes complete with 3.5m cable and UK plug.



Size A4 H 297mm  
W 210mm  
Height Port. 1250mm  
Height Land. 1215mm  
Code **LD1065**



Size A3 H 420mm  
W 297mm  
Height Port. 1303mm  
Height Land. 1250mm  
Code **LD1066**

# Poster Display - Freestanding



## BusyGrip® menu or information stand

Lightweight stand with optional ring binder mechanism

Display multi-page information on this elegant stand. Use a punch to prepare the information before clipping into the integrated 4 ring binder. Alternatively remove the binder mechanism and display the information on the 70° sloping clear acrylic platform. 1110mm high anodised aluminium post is mounted to an attractive heavy base for stability. Optional A4 literature dispenser available which secures to the post beneath the sloping platform.



H 1110mm  
W 470mm  
D 320mm

Code **LD3090**

## BusyGrip® sprung pavement signs

Weatherproof double sided poster frame

Double sided large sized snap frames with weatherproof seals and UV poster protection. Base can be filled with water for extra stability. Two side wheels aid mobility when unit is angled. Easy self assembly.



Size A1 H 841mm  
W 594mm  
Code **LD1090T**



Size A0 H 1189mm  
W 841mm  
Code **LD1089T**



Size H 1524mm  
W 1016mm  
Code **LD1088T**

## Swinging pavement signs

### External double sided A2 poster stand

Seals an A2 poster between clear windowed sleeves. Sturdy stand is designed for the poster to swing freely in the wind, couple this with the heavy base and it will withstand the most inclement weather. Coated steel frame and heavy duty plastic base. Robust swinging brackets securely retain the poster holder.

Takes A2 H 594mm  
W 420mm  
Overall size H 935mm  
W 600mm  
Code **SP1000**



## BusyGrip® indoor A frames

A freestanding double sided poster frame that folds flat for easy portability and storage

Frame is finished in satin anodised aluminium. Suitable for internal or external use but not weatherproof. Available in three popular sizes A1, B2 and B1. Contents are protected by anti-glare UV resistant covers.

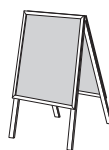

Size A1 H 841mm  
W 594mm  
Stand Height 1050mm  
Code **AF1000**



Size B2 H 700mm  
W 500mm  
Stand Height 950mm  
Code **AF1001**

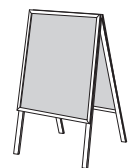

Size B1 H 1000mm  
W 700mm  
Stand Height 1200mm  
Code **AF1002**

# Poster Display and WriteOn® Signage - Freestanding



## BusyGrip® outdoor A frames

Protect your posters with this weatherproof A frame display

The anti-glare UV resistant cover seals to the internal rubber gasket to insure the protection of the displayed information from the elements. The anodised aluminium snap frame is available in three popular sizes A1, B2 and B1. The double sided stand folds flat for easy storage.

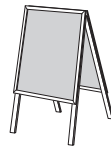

Size A1 H 841mm  
W 594mm  
Stand Height 1150mm  
Code **AF2000**

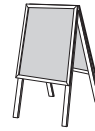

Size B2 H 700mm  
W 500mm  
Stand Height 950mm  
Code **AF2001**

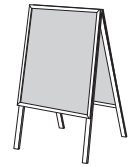

Size B1 H 1000mm  
W 700mm  
Stand Height 1250mm  
Code **AF2002**

## BusyGrip® outdoor blackboard A frame

A1 sized blackboards held within a portable A frame

Blackboard inserts are protected by a clear plastic cover which seals the written message. To change the message simply open the snap frame, remove the blackboard inserts, clean with a damp cloth and reinsert the revised blackboards. The A frame folds flat for transporting and storage. Made of lightweight yet sturdy aluminium. For use with chalk or modern water based pens.



Blackboard A frame  
Size A1 H 841mm  
W 594mm  
Stand Height 1050mm  
Code **AF2004**



Spare blackboard inserts  
Pack of 2  
Size A1 H 841mm  
W 594mm  
Code **AF2005**



## Blackboard pavement sign

### Double sided blackboard stand

This simple stand is designed with a heavy base to withstand moderate wind speed. The blackboard surfaces are ideal for use with chalk or modern water based pens.

Panel	H 850mm
	W 460mm
Overall	H 870mm
	W 523mm
	D 490mm
Code	<b>BP1000</b>



For blackboard pens SEE PAGE 89



## Wood framed blackboard A frames

### Traditional double sided wooden A frame blackboards

Suitable for displaying messages outside of restaurants, cafes, bars etc. A 50mm wide wooden frame surrounds a black surface designed for use with 'chalk' pens, enabling the message to be changed when required. The 600 x 900mm frame folds flat for storage. 1100mm high with a footprint of 700 x 600mm when in use. Suitable pens are available please see page 89.



Size	H 800mm
	W 600mm
Stand Height	1050mm
Code	<b>LD4020</b>



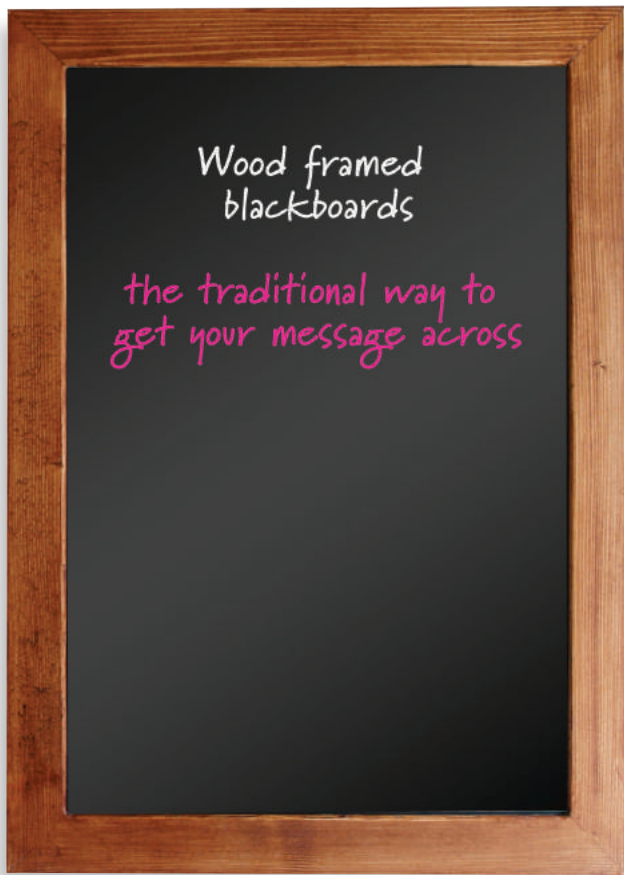

## Wood framed blackboards

### Traditional wall mounted wood framed blackboards

Suitable for displaying messages in restaurants, cafes, bars etc. For use with 'chalk' pens enabling the message to be changed when required. Available in 4 standard sizes up to 1.25m. Can be mounted portrait or landscape. 50mm wooden frame is mounted with a simple fixing kit, supplied. Suitable pens are available please see page 89. Sizes stated are inclusive of the frame.



Size H 700mm  
W 500mm  
Code **LD4010**



Size H 1000mm  
W 500mm  
Code **LD4011**



Size H 900mm  
W 700mm  
Code **LD4012**



Size H 1250mm  
W 700mm  
Code **LD4013**

## Wood edged blackboard signs

### Contemporary styling to traditional signage

Simply unhook the board and lay on a flat surface to assist in writing your message. Stylish wooden edging to the blackboard surface. Available in 4 popular sizes. For use with chalk or modern water based pens - see page 89. Hooks and fixings supplied. Ideal for use in cafés and restaurants.



Size H 600mm  
W 400mm  
Code **LD4030**



Size H 900mm  
W 400mm  
Code **LD4031**



Size H 800mm  
W 600mm  
Code **LD4032**



Size H 1150mm  
W 600mm  
Code **LD4033**

# WriteOn® coloured glass information boards

Display your messages or menus in style

A range of attractive glass dry-wipe boards which also accept super strength magnets. The glass board stands proud of the wall on special chrome fixings, supplied, adding to the visual impact. Made from 4mm toughened safety glass in a choice of 10 colours with a steel back. Ideal for restaurants, bars and reception areas.

**TO ORDER:**

Please state the product code followed by the glass colour code required

EXAMPLE: 600 x 450mm with orange glass = **G4560/OR**



G5050/SK



G5050/RD



G4560/LM



G5050/VI



G4560/OR



G6090/BK



**All 10 colours**

Size H 500mm  
W 500mm  
Code **G5050**

**All 10 colours**

Size H 600mm  
W 450mm  
Code **G4560**

**White or black**

Size H 900mm  
W 600mm  
Code **G6090**

**White or black**

Size H 1000mm  
W 650mm  
Code **G6510**



For larger white glass boards please SEE PAGE 75



# WriteOn® Signage - Wall and Freestanding

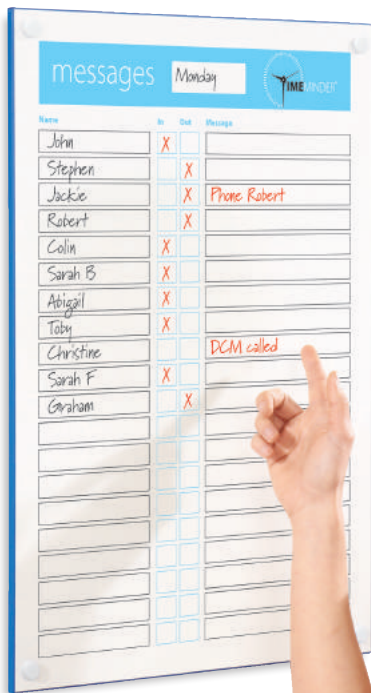

## Timeminder® in-out message board

### Simple in-out and message board

This simple printed drywipe board allows you to know if a member of staff is in the building. Can also be used to record a message if they are out or indicate where they are. 600 x 450mm blue edged drywipe board. Simple through the board fixing and cover caps. For use with drywipe pens - see page 89. Other printed drywipe boards and planners are featured on pages 82 - 88.

Size H 600mm  
W 450mm  
Code **46836**



## Freestanding whiteboard signs

### Magnetic double sided drywipe signs

A range of double sided signs available in three useful shapes - rectangular, octagonal and directional arrow. The Arrow sign angles and locks in chosen position, Whiteboard surface accepts magnets and is designed for use with drywipe markers. Robust plastic frame, pole and circular base which can be filled with water or sand for extra stability.



**Arrow**  
Size H 430mm  
W 650mm  
Stand Height 1632mm  
Code **G4173BL**

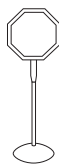

**Octagon**  
Size H 565mm  
W 565mm  
Stand Height 1650mm  
Code **G4118BL**



**Rectangle**  
Size H 645mm  
W 435mm  
Stand Height 1650mm  
Code **G4117BL**

**Set of 3 signs**  
(1 of each type)  
Code **G400SET**



# ShowPoint® in-out board - for 10 people

1 header module and 10 personnel modules

Styled in cool white with a striking accent colour.

Names can be created using -

- 1 Interchangeable letters - Supplied
- 2 Computer generated printed strips  
Header - 222 x 16mm  
Indicator - 156 x 16mm
- 3 Hand written - Insert card and pen provided

Supplied with easy to read characters which are up to 100% larger than some other systems. Name plates have a clear cover to prevent casual interference. Installation takes a matter of minutes, simply affix the mounting post to the wall and snap each of the modules in place. Anti-tamper strips supplied to lock name plates in position for added security if required. The versatile Showpoint® Kit can also be used as a modular directional signage system

Size	H 534mm	Extra Letters
	W 267mm	Pack of 447 letters and numbers
	D 41mm	Code <b>SPLN400</b>
Code	<b>SPSK100</b>	

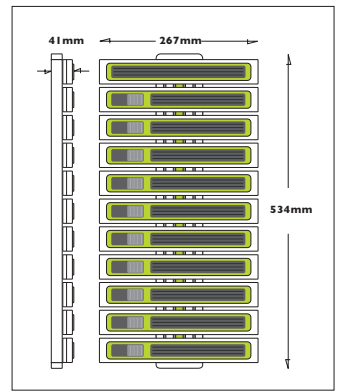

# SHOW•POINT

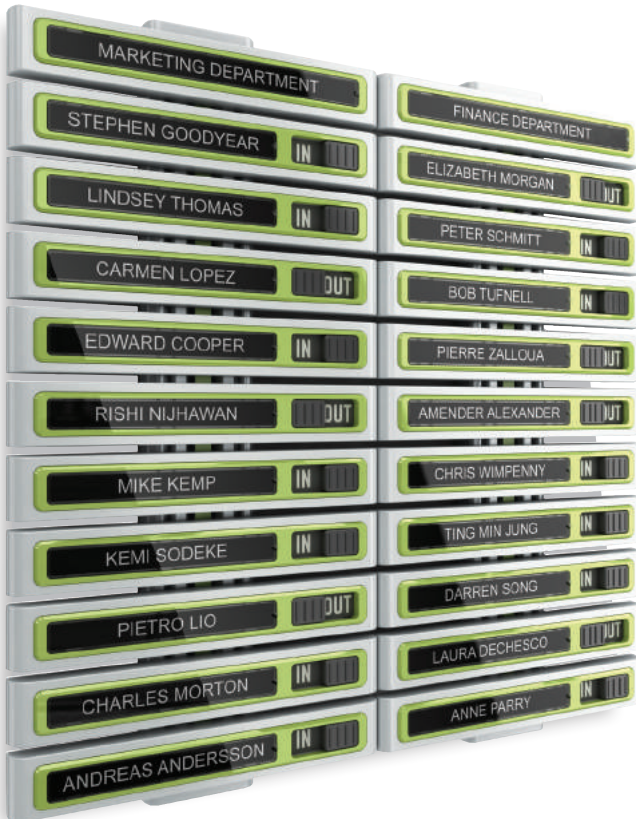

# ShowPoint® in-out board - for 20 people

2 header modules and 20 personnel modules

Styled in cool white with a striking accent colour.

Names can be created using -

- 1 Interchangeable letters - Supplied
- 2 Computer generated printed strips  
Header - 222 x 16mm  
Indicator - 156 x 16mm
- 3 Hand written - Insert card and pen provided

Supplied with easy to read characters which are up to 100% larger than some other systems. Name plates have a clear cover to prevent casual interference. Requires simple self assembly with fully illustrated instructions. All modules can be locked onto the mounting post with the 2 concealed anti-tamper locking strips for added security. The versatile Showpoint® Kit can also be used as a modular directional signage system

Size	H 534mm	Extra Letters
	W 534mm	Pack of 447 letters and numbers
	D 41mm	Code <b>SPLN400</b>
Code	<b>SPSK200</b>	



# Signage - Desk and Wall Mounted



## ShowPoint® door and desk modules

Contemporary styling in cool white with a striking accent colour

These signage modules can be used for information and naming purposes, alone or in conjunction with other showpoint products.

Names can be created using -

- 1 Interchangeable letters - Supplied
- 2 Computer generated printed strips 222 x 16mm
- 3 Hand written - Insert card and pen provided

All plates have a clear cover to prevent casual interference. Simple self assembly.

Door or desk name plates - all in one box

Simply add a name and mount to a door or the desk stand supplied. Pack of 3 units supplied with 2 keyhole fixing and screws or adhesive foam pads for wall fixing plus 3 aluminium stands for conversion to desk plates.

# SHOWPOINT

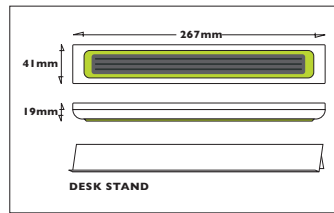

Pack of 3

Size H 41mm  
W 267mm  
D 19mm

Code **SPDD300**

Extra Letters

Pack of 447 letters and numbers  
Code **SPLN400**

## ShowPoint® indicator modules

Door plate indicators or directional plates

Use the 'IN/OUT', and/or 'No Entry' inserts to create attractive door indicators. Alternatively use the selection of arrow inserts to assemble a series of directional plates. Pack of 3 units supplied with keyhole fixings and screws and adhesive foam pads for wall or door fixing.

Names can be created using -

- 1 Interchangeable letters - Supplied
- 2 Computer generated printed strips 222 x 16mm
- 3 Hand written - Insert card and pen provided

Pack of 3

Size H 41mm  
W 267mm  
D 19mm

Code **SPDP200**

Extra Letters

Pack of 447 letters and numbers  
Code **SPLN400**

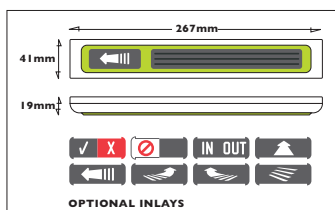

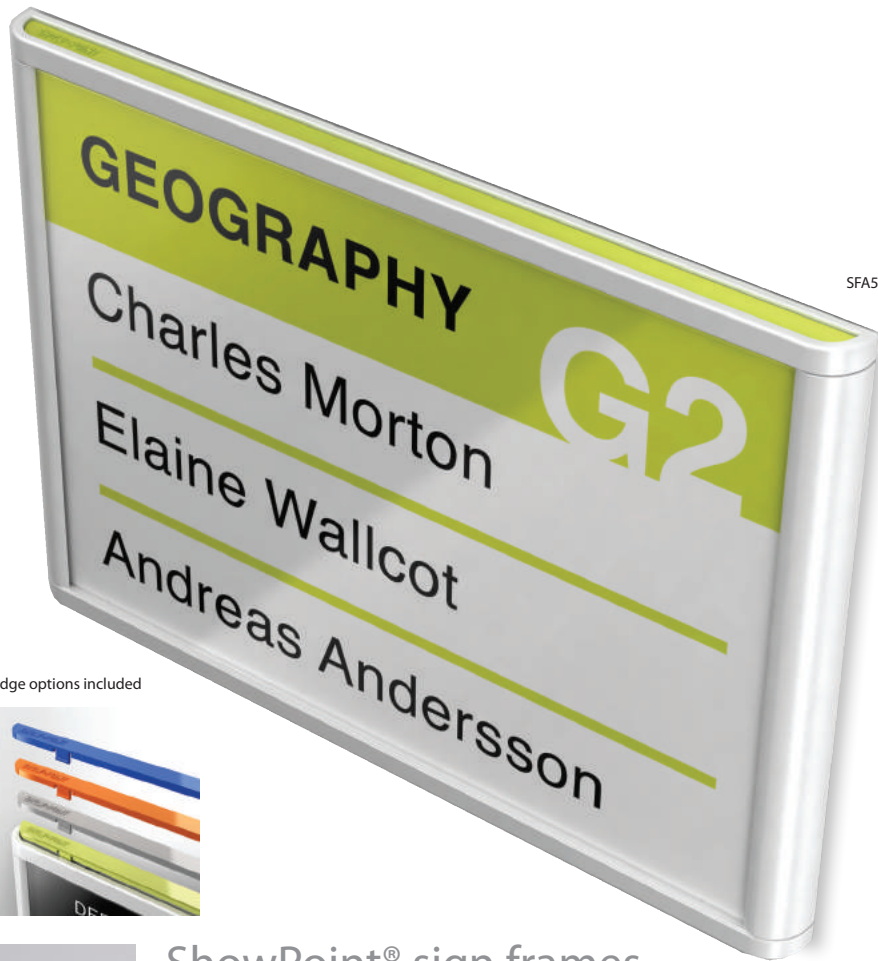

Size range



Edge options included



## ShowPoint® sign frames

### Economical and contemporary DIY sign system

Create signs in-house and print on any A4 or A3 printer via your PC or Mac; saving on expensive outsourced print services. A choice of five sizes to take A6, A5, A4, A3, & 1/2A4 inserts. All signs can be mounted portrait or landscape and can be personalised with a choice of brightly coloured

decor strips. For corridor applications there is a double sided flag sign supplied complete with heavy duty mounting bracket. All fixings provided.

### Flag display

This 1/2A4 size double sided unit protrudes at right angles to the wall, therefore ideal for identifying rooms in corridors.

# SHOWPOINT

Remove snap fit side to change message



Flag - double sided



Size A6 H 148mm  
W 105mm  
External H 164mm  
W 119mm  
Code **SFA6**



Size A5 H 210mm  
W 148mm  
External H 226mm  
W 162mm  
Code **SFA5**



Size 1/2A4 H 297mm  
W 105mm  
External H 313mm  
W 119mm  
Code **SFHA4**



Size A4 H 297mm  
W 210mm  
External H 313mm  
W 224mm  
Code **SFA4**

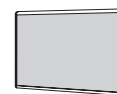

Size A3 H 297mm  
W 420mm  
External H 313mm  
W 434mm  
Code **SFA3**



Flag H 105mm  
W 297mm  
External H 119mm  
W 313mm  
Code **SFF297**

# Signage - Wall Mounted



## ShowPoint® wall sign system

A stylish curved wall signage system to take printed paper sign inserts

This versatile signage system features an attractive aluminium curved profile with contrasting end caps. Available in a range of 28 size variants. 4 depths 68mm,

90mm, 120mm and 162mm, to suit the amount and/or size of lettering to be displayed. The printed inserts are easy to install and change with the special suction tool provided. Each sign insert lays flat against its protective clear cover due to the curvature of the design. Each unit is easily mounted by use of their self adhesive backing strips.

### Guide to producing the Showpoint® wall sign inserts

Create a document to the size of the 'insert' required. Type your information into the document starting with the longest line of text. Ensure that this fits comfortably within the document size. Repeat with the same size text for all the other inserts to achieve a consistent look. To print, ensure the correct printer has been chosen. Inserts up to 297mm wide should fit on an A4 printer. Inserts up to 420mm wide should fit on an A3 printer. Inserts over these widths will require printing on a large format printer.



Size H 68mm  
W 106mm  
Insert size 52 x 100mm  
Code **52100**



Size H 68mm  
W 156mm  
Insert size 52 x 150mm  
Code **52150**



Size H 68mm  
W 206mm  
Insert size 52 x 200mm  
Code **52200**

## Showpoint® 68mm

68mm deep signs in a range of 8 different lengths from 106 to 456mm. Please refer to each diagram for the dimension and to see the size of printed direction insert that each will take.



Size H 68mm  
W 256mm  
Insert size 52 x 250mm  
Code **52250**



Size H 68mm  
W 306mm  
Insert size 52 x 300mm  
Code **52300**



Size H 68mm  
W 356mm  
Insert size 52 x 350mm  
Code **52350**



Size H 68mm  
W 406mm  
Insert size 52 x 400mm  
Code **52400**



Size H 68mm  
W 456mm  
Insert size 52 x 450mm  
Code **52450**

# SHOWPOINT

## ShowPoint® 90mm

90mm deep signs in a range of 8 different lengths from 156 to 506mm. Please refer to each diagram for the dimension and to see the size of printed insert that each will take.



Size H 90mm  
W 156mm  
Insert size 74 x 150mm  
Code **74150**



Size H 90mm  
W 206mm  
Insert size 74 x 200mm  
Code **74200**



Size H 90mm  
W 256mm  
Insert size 74 x 250mm  
Code **74250**



Size H 90mm  
W 306mm  
Insert size 74 x 300mm  
Code **74300**



Size H 90mm  
W 356mm  
Insert size 74 x 350mm  
Code **74350**



Size H 90mm  
W 406mm  
Insert size 74 x 400mm  
Code **74400**



Size H 90mm  
W 456mm  
Insert size 74 x 450mm  
Code **74450**



Size H 90mm  
W 506mm  
Insert size 74 x 500mm  
Code **74500**



Size H 120mm  
W 256mm  
Insert size 105 x 250mm  
Code **105250**



Size H 120mm  
W 306mm  
Insert size 105 x 300mm  
Code **105300**



Size H 120mm  
W 356mm  
Insert size 105 x 350mm  
Code **105350**



Size H 120mm  
W 406mm  
Insert size 105 x 400mm  
Code **105400**



Size H 120mm  
W 506mm  
Insert size 105 x 500mm  
Code **105500**



Size H 120mm  
W 606mm  
Insert size 105 x 600mm  
Code **105600**

## ShowPoint® 120mm

120mm deep signs in a range of 6 different lengths from 256 to 606mm. Please refer to each diagram for the dimension and to see the size of printed sign insert that each will take.



## ShowPoint® 162mm

162mm deep signs in a range of 6 different lengths from 306 to 656mm. Please refer to each diagram for the dimension and to see the size of printed insert that each will take.



Size H 162mm  
W 306mm  
Insert size 148 x 300mm  
Code **148300**

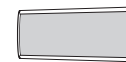

Size H 162mm  
W 356mm  
Insert size 148 x 350mm  
Code **148350**



Size H 162mm  
W 406mm  
Insert size 148 x 400mm  
Code **148400**



Size H 162mm  
W 506mm  
Insert size 148 x 500mm  
Code **148500**



Size H 162mm  
W 606mm  
Insert size 148 x 600mm  
Code **148600**



Size H 162mm  
W 656mm  
Insert size 148 x 650mm  
Code **148650**

# Signage - Wall Mounted



## QuickSign snap frame signage system

### Low cost signage solution to take 'A' sized inserts

Economical sign holders that operate like a snap poster frame. Easy to mount and simple to use, QuickSign is available in 5 convenient sizes all being derivatives of A4.

Enables you to create your own signage in-house on any standard A4 printer. QuickSign can be mounted on curved walls or circular columns, due to the flexible backing plate. These popular signs can be mounted in portrait or landscape orientation.

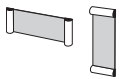

Size 1/2A5 H 77mm  
W 239mm  
Insert size 74 x 210mm  
4 from A4 sheet  
Code **BS5000**

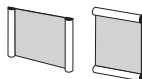

Size A5 H 151mm  
W 239mm  
Insert size 148 x 210mm  
2 from A4 sheet  
Code **BS5001**

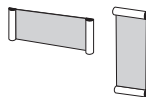

Size 1/2A4 H 108mm  
W 326mm  
Insert size 105 x 297mm  
2 from A4 sheet  
Code **BS5002**

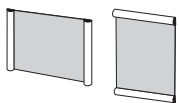

Size A4 H 213mm  
W 326mm  
Insert size 210 x 297mm  
1 from A4 sheet  
Code **BS5003**

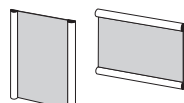

Size A4 H 300mm  
W 239mm  
Insert size 297 x 210mm  
1 from A4 sheet  
Code **BS5004**



### Guide to producing the QuickSign inserts

Create an A4 document and divide in 1/4s for the 1/2A5, 1/2s for the 1/2A4 or A5 inserts. Type your information into the document starting with the longest line of text. Ensure that this fits comfortably within the document size. Repeat with the same size text for all the other inserts to achieve a consistent look as required. Print the inserts on an A4 printer. Trim in 1/2 or 1/4 as required.

# Literature Display

- 126 - 127 Coloured Displays
- 128 - 131 Clear Acrylic Displays
- 132 - 133 Clear Acrylic Desktop Displays
- 134 - 135 Shelf Style Displays
- 136 - 138 Wooden Displays
- 139 - 142 Steel Mesh Displays
- 142 - 143 Steel Displays
- 144 - 145 Steel Wire Displays
- 146 Brochure Stackers



# Leaflet Display - Coloured



LD1000/LM

LD1017/OR

LD1002/LC

## Panorama wall mounted dispensers

Ever popular colourful leaflet dispensers - now with even more colour choice

Available in 6 sizes to suit a variety of leaflet sizes and capacities, and in a choice of 10 colours including 3 new vibrant colours - Orange, Lime and Lilac. Overlapping clear leaflet holders are housed in a curved colourful moulded body that mounts directly to the wall with concealed fixings. Each unit is the same height so can be mounted side by side.

### TO ORDER:

Please state the product code followed by the colour code required

EXAMPLE: Panorama A4 3 pocket in Lime = **LD1000/LM**



Capacity 3 x A4  
Size H 521mm  
W 267mm  
Code **LD1000**



Capacity 6 x A4  
Size H 521mm  
W 502mm  
Code **LD1001**



Capacity 4 x A5  
Size H 521mm  
W 184mm  
Code **LD1002**



Capacity 8 x A5  
Size H 521mm  
W 352mm  
Code **LD1016**



Capacity 4 x 1/3 A4  
Size H 521mm  
W 134mm  
Code **LD1003**



Capacity 8 x 1/3 A4  
Size H 521mm  
W 255mm  
Code **LD1017**

### Colour options





## Vibrant 4 sided revolving dispensers

3 new vibrant colours for these popular carousel dispensers with clear acrylic pockets

The 30mm capacity pockets do not overlap, showing the full front cover of the brochure/leaflet. Can accommodate A4, A5 and 1/3A4 sized documents in 12, 16 or 32 pockets. 3 colours; Orange, Lime or Lilac on a chrome central column with grey star base. Optional header (as shown) to enable personalisation.

### TO ORDER:

Please state the product code followed by the body colour code required

EXAMPLE: 12 x A4 with Orange body = **LD2500/OR**

### NEW vibrant colour options



Orange Lime Lilac

LD2003/RD



LD2000/RD

LD2800/OR



LD2500/OR



LD2700/LM



LD2500/LC



Capacity 12 x A4  
Size H 1690mm  
W 560mm  
D 560mm  
Vibrant **LD2500**  
Traditional **LD2000**



Capacity 16 x A5  
Size H 1690mm  
W 560mm  
D 560mm  
Vibrant **LD2600**  
Traditional **LD2001**



Capacity 32 x 1/3A4  
Size H 1690mm  
W 560mm  
D 560mm  
Vibrant **LD2700**  
Traditional **LD2002**



Optional Header  
Size H 160mm  
W 560mm  
D 560mm  
Vibrant **LD2800**  
Traditional **LD2003**

## Traditional 4 sided revolving dispensers

Popular carousel with clear acrylic pockets

Revolving leaflet dispenser with clear acrylic pockets mounted onto a 4 sided central carousel. The 30mm capacity pockets do not overlap, showing the full front cover of the brochure/leaflet. Can accommodate A4, A5 and 1/3A4 sized documents in 12, 16 or 32 pockets. Available in Blue, Red, White and Grey with grey star base and chrome central column. Optional header (as shown) to enable personalisation.

### TO ORDER:

Please state the product code followed by the body colour code required

EXAMPLE: 12 x A4 with red body = **LD2000/RD**

### Traditional colour options



Grey Blue Red White



# Leaflet Display - Clear Acrylic



## Crest wall mounted literature dispensers

### Contemporary leaflet dispenser

The simple clear leaflet holders are complimented with modern satin anodised supports. Dividers are supplied to enable each pocket to be converted from A4 to accept 1/3 A4 sized leaflets. Therefore the 9 x A4 can also be converted to accept up to 18 x 1/3 A4, and the 3 x A4 can be converted to take up to 6 x 1/3 A4. Supplied with wall fixings.

Capacity	3 x A4 or 6 x 1/3 A4	Capacity	9 x A4 or 18 x 1/3 A4
Size	H 387mm W 806mm D 127mm	Size	H 1041mm W 806mm D 127mm
Code	<b>G4133SL</b>	Code	<b>G4134SL</b>



## Crest freestanding literature dispensers

### A sleek and elegant freestanding leaflet display

The simple clear leaflet holders are complimented with modern satin anodised frame. Dividers are supplied to enable each pocket to be converted from A4 to accept 1/3 A4 sized leaflets. Adjustable button feet to aid stability.

Capacity	9 x A4 or 18 x 1/3A4
Size	H 1594mm W 806mm D 508mm
Code	<b>G4135SL</b>

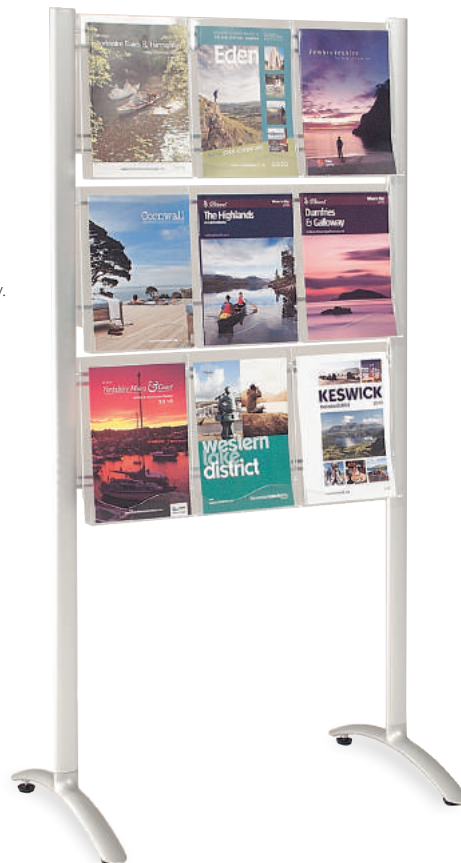

Some configuration options by using dividers provided

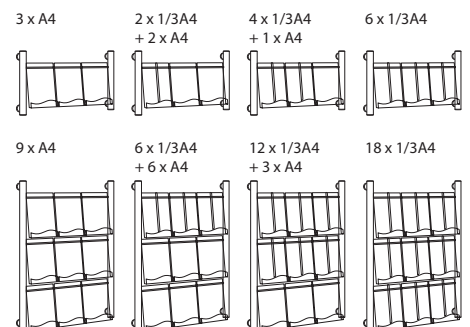

## All Clear literature dispensers

The clear choice for a clear view

Clever yet simple concept of a totally clear leaflet dispenser with holders that do not overlap, allowing the full front of every brochure to be displayed. The entire product is manufactured from clear moulded acrylic, therefore the surrounding decor is also not compromised. Wide range of sizes and configurations are available including mixed format units.



G10110

G10101S



Capacity 12 x A4  
Size H 1245mm  
W 762mm  
Wall Mounted **G10111**



Capacity 12 x 1/3 A4  
+ 6 x A4  
Size H 1143mm  
W 762mm  
Wall Mounted **G10110**

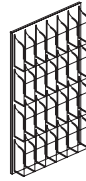

Capacity 24 x 1/3 A4  
Size H 1041mm  
W 762mm  
Wall Mounted **G10109**

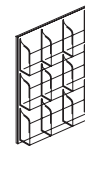

Capacity 9 x A4  
Size H 934mm  
W 762mm  
Wall Mounted **G10101**  
Freestanding **G10101S**

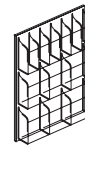

Capacity 6 x 1/3 A4  
+ 6 x A4  
Size H 883mm  
W 762mm  
Wall Mounted **G10107**  
Freestanding **G10107S**

G10110

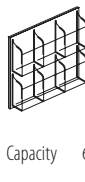

Capacity 6 x A4  
Size H 626mm  
W 762mm  
Wall Mounted **G10103**  
Freestanding **G10103S**



Capacity 6 x 1/3 A4  
+ 3 x A4  
Size H 572mm  
W 762mm  
Wall Mounted **G10106**  
Freestanding **G10106S**



Capacity 12 x 1/3 A4  
Size H 521mm  
W 762mm  
Wall Mounted **G10112**  
Freestanding **G10112S**



Capacity 12 x A5  
Size H 762mm  
W 762mm  
Wall Mounted **G10127**  
Freestanding **G10127S**



Capacity 6 x A5  
Size H 514mm  
W 591mm  
Wall Mounted **G10138**

# Leaflet Display - Clear Acrylic



## All Clear Premier wall mounted literature display

Attractive clear wall displays

Contemporary acrylic design for wall mounting in multiples of 5 pockets. Mount units side by side for larger displays of A4 literature. Holds 32mm of literature in each pocket. Also available as desktop and revolving floor stands to match.



Capacity	5 x A4
Size	H 578mm W 241mm D 150mm
Code	<b>6103102</b>

## All Clear Premier desk top literature display

Attractive clear 3 pocket desk displays

Contemporary acrylic design. Stand units side by side for larger displays of A4 literature. Holds 32mm of literature in each pocket. Also available are wall mounted and revolving floor stands to match.



Capacity	3 x A4
Size	H 330mm W 240mm D 300mm
Code	<b>6102702</b>

## All Clear Premier revolving literature floor stands

Premier clear display units for maximum impact

Three sided carousel unit with 30 pocket capacity. Each A4 pocket is 32mm deep, and is moulded in clear polystyrol. The carousel rotates on a central column which is mounted on a mobile base.

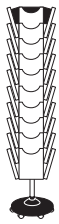

Capacity 30 x A4  
 Size H 1720mm  
 W 440mm  
 D 440mm  
 Code **6255802**



LD2010 +  
 LD2011 +  
 LD2012 +  
 LD2013



## Pirouette literature dispenser

Modular leaflet dispenser – tailored to your needs

Create your own combination by selecting the three tiers of your choice together with a pole and base unit. Each tier has eight individual pockets to accommodate A4, A5 or 1/3A4 documents. Each tier rotates individually and can be replaced at any time, to match your current requirement.

**TO ORDER:**

Please order a pole assembly and up to 3 of any tier.

EXAMPLE: One of each size =

**LD2010 + LD2011 + LD2012 + LD2013**



**Pole**  
 Size H 1560mm  
 W 560mm  
 D 560mm  
 Code **LD2010**

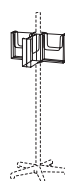

Capacity 8 x A4  
 Code **LD2011**

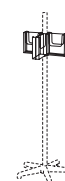

Capacity 8 x A5  
 Code **LD2012**

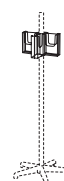

Capacity 8 x 1/3A4  
 Code **LD2013**



EASY SELF ASSEMBLY

ALL CLEAR PREMIER



32MM CAPACITY  
 30 POCKETS  
 HOLDS A4 LITERATURE

PIROUETTE



32MM CAPACITY  
 SEE DIAGRAMS  
 HOLDS A4 LITERATURE  
 HOLDS A5 LITERATURE  
 HOLDS 1/3A4 LITERATURE



MADE IN UK

# Leaflet Display - Clear Acrylic Desktop

5 x LD3006



## 3 tier expandable desktop dispensers

Clear, compact and low cost

Three tier unit available in A4, A5 and 1/3 A4 formats, moulded in crystal clear styrene. All units can be joined together with optional clips.



Capacity 3 x 1/3A4  
Size H 230mm  
W 112mm  
D 116mm  
Code **LD3006**



Capacity 3 x A5  
Size H 230mm  
W 160mm  
D 116mm  
Code **LD3014**



Capacity 3 x A4  
Size H 330mm  
W 228mm  
D 116mm  
Code **LD3005**

Joining Clips  
Packet of 10  
Code **LD3013**

## Single pocket literature dispenser

Single pocket leaflet dispensers ideal for mounting on loop nylon display systems (see pages 148 - 158) or to a wall

These leaflet dispensers have a large capacity A4, A5 or 1/3A4 pocket. The all clear acrylic design allows the whole of the literature cover to be viewed. Mount using the Busyfix coins provided or screw fix to a suitable wall.



Capacity A4  
Code **LD1005**



Capacity A5  
Code **LD1006**



Capacity 1/3A4  
Code **LD1007**



## Revolving desktop literature dispensers

Revolving clear acrylic pockets to maximise visibility

White top and base hold 4 pockets which are available in 3 formats A4, A5 and 1/3A4. 30mm deep capacity in each pocket. The all clear acrylic pocket design allows the whole of the literature cover to be viewed.

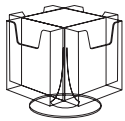

Capacity 4 x A4  
Size H 250mm  
W 305mm  
D 305mm  
Code **LD3000**

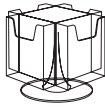

Capacity 4 x A5  
Size H 180mm  
W 245mm  
D 245mm  
Code **LD3001**

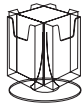

Capacity 4 x 1/3A4  
Size H 180mm  
W 200mm  
D 200mm  
Code **LD3002**

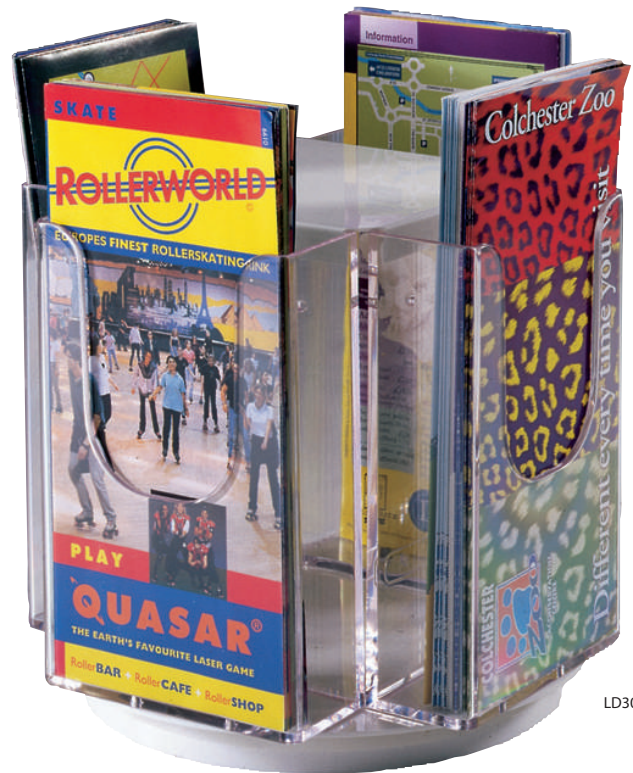

LD3002

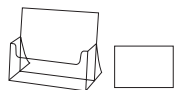

**A4 Landscape base unit**  
Size H 200mm  
W 310mm  
D 65mm  
Code **LD3015**

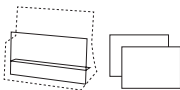

Insert to convert A4 Landscape to 2 x A4 Landscape  
Size H 200mm  
W 310mm  
D 65mm  
Code **LD3020**

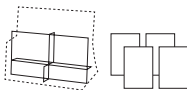

Insert to convert A4 Landscape to 4 x A5 Portrait  
Size H 200mm  
W 310mm  
D 65mm  
Code **LD3016**

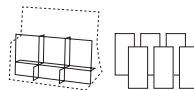

Insert to convert A4 Landscape to 6 x 1/3A4 Portrait  
Size H 200mm  
W 310mm  
D 65mm  
Code **LD3017**

## Variable format desktop dispensers

Three base units with a choice of inserts, enable the format of the dispenser to be changed as needed

Each base unit is sized for A4 (portrait or landscape) or A5. The inserts divide the pocket for smaller document sizes.

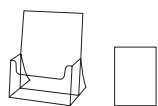

**A4 Portrait base unit**  
Size H 280mm  
W 225mm  
D 65mm  
Code **LD3021**

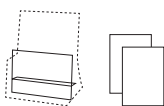

Insert to convert A4 Portrait to 2 x A4 Portrait  
Size H 280mm  
W 225mm  
D 65mm  
Code **LD3022**

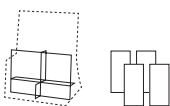

Insert to convert A4 Portrait to 4 x 1/3A4 Portrait  
Size H 280mm  
W 225mm  
D 65mm  
Code **LD3023**



**A5 Portrait base unit**  
Size H 200mm  
W 156mm  
D 57mm  
Code **LD3024**

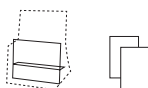

Insert to convert A5 Portrait to 2 x A5 Portrait  
Size H 200mm  
W 156mm  
D 57mm  
Code **LD3025**



LD3015 + LD3017

# Leaflet Display - Shelf Style



## Cinco literature stands

2 mobile brochure stands with a functional yet contemporary design

Steel frame with angled plastic shelves. Shelves hold up to 35mm of material. The larger unit can house a variety of different sized materials on 700mm wide shelves. Both units are ideal for use in reception areas. Locking castors. Easy self assembly.



Capacity 12 x A4  
Size H 1660mm  
W 820mm  
D 510mm  
Code **LD4004**

Capacity 4 x A4  
Size H 1660mm  
W 340mm  
D 510mm  
Code **LD4003**

## NEW Quatro premier literature stands

Premier leaflet display with adjustable steel or transparent acrylic shelves

The attractive new design enables the shelves to be independently set at 15°, 45° or 90° during assembly; to suit your presentation requirements. Locking castors are standard. These contemporary leaflet dispensers are designed and manufactured to a high standard. Available in 4 x A4 or 12 x A4 models. As there are no dividers or separators the shelves can accommodate virtually any style of leaflet or brochure. Satin anodised aluminium framework is complimented with either powder coated steel shelves or transparent acrylic shelves. Supplied with 4 castors for mobility.



### Transparent Acrylic Shelf Stands

Capacity 12 x A4  
Size H 1760mm  
W 940mm  
D 425mm  
Code **A6813402**

Capacity 4 x A4  
Size H 1760mm  
W 370mm  
D 425mm  
Code **A6813302**

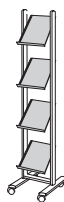
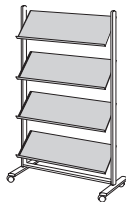

### Steel Shelf Stands

Capacity 12 x A4  
Size H 1760mm  
W 940mm  
D 425mm  
Code **S6813499**

Capacity 4 x A4  
Size H 1760mm  
W 370mm  
D 425mm  
Code **S6813399**





## Shelf style wall mounted display

Simple sleek and modern design, sold as a single unit or as a pack of 3

Can be mounted one above the other or side by side in multiples. The full height strong 6mm acrylic facia panel allows the entire artwork to be seen clearly. Suitable for literature up to A4, there are no dividers allowing a fully flexible open space for storing magazines, brochures, books and other types of literature. The interior pocket has a wide depth of 58mm allowing multiple items to be stored one in front of the other. Supplied ready assembled. Available in a choice of beech, black, white or blue finish.

Custom sizes and colours are available for volume enquiries, contact your representative for details.

Capacity 58mm  
 Size H 222mm  
 W 1314mm  
 D 92mm

Single  
 Beech **LDM1000/BH**  
 Blue **LDM1000/BL**  
 White **LDM1000/WH**  
 Black **LDM1000/BK**

Pack of 3  
 Beech **LDM1000PK/BH**  
 Blue **LDM1000PK/BL**  
 White **LDM1000PK/WH**  
 Black **LDM1000PK/BK**



LDM1000PK



LDM1000/BL

LDM1000/WH

LDM1000/BK

# Leaflet Display - Wooden



G4624NA

## Bamboo wall mounted literature dispensers



Stylish displays made from sustainable natural bamboo

This ecological design is constructed from 100% natural bamboo. These wall mounted units allow for the display of multiple of 3, 4 or 9 x A4 literature. Dividers are also included for any pocket to be converted from A4 to 2 x 1/3A4. Mount either unit side by side for larger displays. Each compartment holds 45mm thickness of literature. Also available is a 4 compartment floor stand to match.

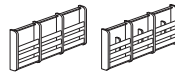

Capacity 3 x A4 or  
6 x 1/3A4  
Size H 337mm  
W 737mm  
D 45mm  
Code **G4620NA**



Capacity 4 x A4 or  
8 x 1/3A4  
Size H 648mm  
W 495mm  
D 45mm  
Code **G4623NA**

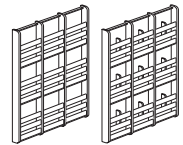

Capacity 9 x A4 or  
18 x 1/3A4  
Size H 959mm  
W 737mm  
D 45mm  
Code **G4624NA**

## Bamboo freestanding literature dispensers

Stylish floor display made from sustainable natural bamboo

This ecological design is constructed from 100% natural bamboo. This stand allows for the display of multiples of 4 x A4 or up to 8 x 1/3A4 literature with the dividers included. Each compartment holds 45mm thickness of literature.

Capacity 4 x A4 or  
8 x 1/3A4  
Size H 1435mm  
W 254mm  
D 464mm  
Code **G4622NA**



G4622NA



G4620NA

G4623NA



# Oak Deluxe wall mounted literature dispensers

## Traditional solid wood leaflet dispenser

Wall mounted leaflet dispenser framed in oak finish solid wood. Clear acrylic pocket front allowing the full front of every brochure to be displayed. This ensures the full front cover of the displayed information is on clear view. A wide range of sizes and configurations are available, including mixed format units. Wall fixings included.



G48101



G48107

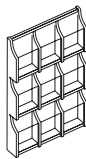

Capacity 9 x A4  
 Size H 972mm  
 W 756mm  
 Code **G48101**

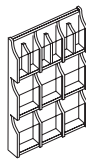

Capacity 6 x 1/3 A4 + 6 x A4  
 Size H 972mm  
 W 756mm  
 Code **G48107**

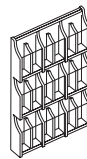

Capacity 18 x 1/3 A4  
 Size H 972mm  
 W 756mm  
 Code **G48102**

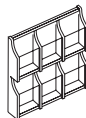

Capacity 6 x A4  
 Size H 667mm  
 W 756mm  
 Code **G48103**

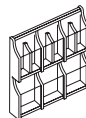

Capacity 6 x 1/3 A4 + 3 x A4  
 Size H 667mm  
 W 756mm  
 Code **G48106**

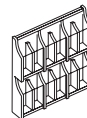

Capacity 12 x 1/3 A4  
 Size H 667mm  
 W 756mm  
 Code **G48112**



Capacity 4 x A4  
 Size H 667mm  
 W 508mm  
 Code **G48104**

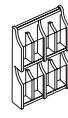

Capacity 8 x 1/3 A4  
 Size H 667mm  
 W 508mm  
 Code **G48105**

# Leaflet Display - Wooden

G4330MO



G4330MH



G4331MO



G4331MH



## Wooden wall literature dispensers

Elegant wall mounted display racks with durable Oak or Mahogany wood finish

This traditional design allows the wall mounting of A4 literature in multiples of 5 or 12 separate compartments. Mount either unit side by side for larger displays. Each attractive scoop front compartment holds 20mm of literature.



Capacity 5 x A4  
 Size H 603mm  
 W 286mm  
 D 95mm  
 Oak **G4330MO**  
 Mahogany **G4330MH**

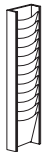

Capacity 12 x A4  
 Size H 1238mm  
 W 286mm  
 D 95mm  
 Oak **G4331MO**  
 Mahogany **G4331MH**



G4330MH

## Wooden revolving literature dispensers

4 sided revolving floor stand in Oak or Mahogany wood finish

This sturdy design allows for a large amount of A4 literature to be displayed in 48 separate scoop fronted compartments. Holds 20mm of literature in each. The unit rotates through 360° to allow for easy access to all sides.



G4335MO



Capacity 48 x A4  
 Size H 1257mm  
 W 451mm  
 D 451mm  
 Oak **G4335MO**  
 Mahogany **G4335MH**

G4335MH



HOLDS A4 LITERATURE



20MM CAPACITY SEE DIAGRAMS



REVOLVING



20MM CAPACITY 48 POCKETS

## Wave freestanding literature dispensers

### Eye-catching leaflet dispenser

Stylish leaflet dispenser with four oversized A4 shelves, mounted on a sturdy steel frame. Finished in a choice of three powder coat colours – White, Grey and Black. Header panel at the top can take vinyl stickers/letters for personalisation. Supplied with a set of four optional castors for mobility. Simple self assembly.



Capacity 4 x A4  
 Size H 1430mm  
 W 350mm  
 D 310mm

Grey **LDF8GS**  
 White **LDF8W**  
 Black **LDF8B**

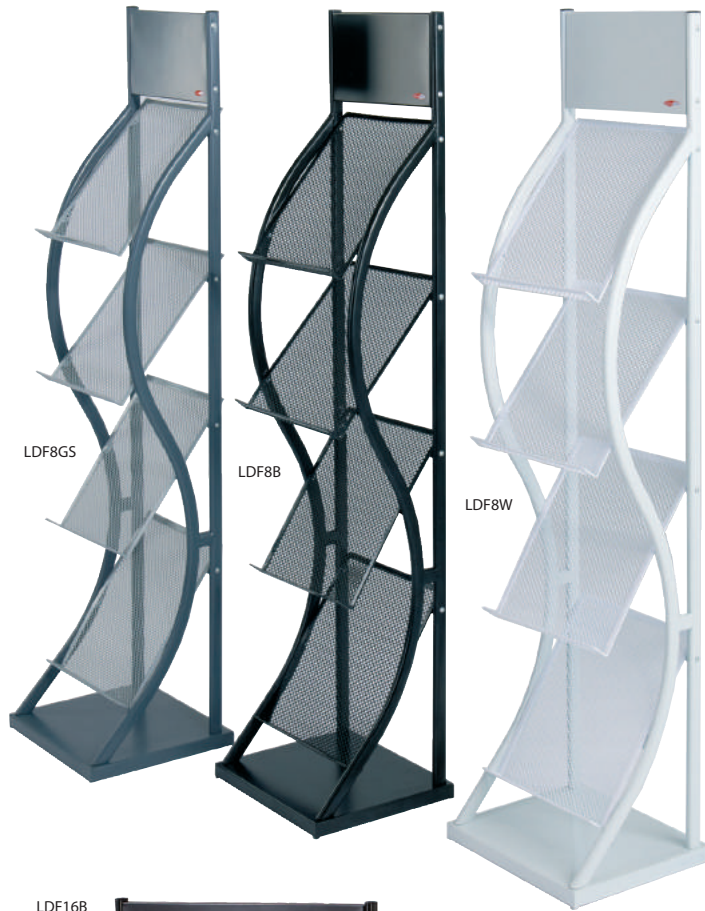

## Wave Wider freestanding literature dispensers

Introducing a wider version of the popular Wave Literature Dispenser

Same contemporary design as the original Wave Literature Dispenser, the wider unit allows for 2 A4 pieces of literature to be displayed side by side. Finished in a choice of three powder coat colours – White, Grey and Black. Header panel at the top can take vinyl stickers/letters for personalisation. Simple self assembly.



Capacity 8 x A4  
 Size H 1430mm  
 W 500mm  
 D 310mm

Grey **LDF16GS**  
 White **LDF16W**  
 Black **LDF16B**

# Leaflet Display - Steel Mesh



G5578BL



G5579BL

## Mesh wall mounted literature dispensers

### Smart wire mesh brochure dispenser

Wall mounted brochure dispenser available with 5 or 10 large capacity A4 pockets, finished in black powder coated wire mesh. The overlapping tiered pockets presents almost half of the front cover of each leaflet. Easy wall mounting, fixings supplied.

Capacity	5 x A4	Capacity	10 x A4
Size	H 720mm W 260mm D 90mm	Size	H 1290mm W 260mm D 90mm
Code	<b>G5578BL</b>	Code	<b>G5579BL</b>



## Mesh desktop literature dispensers

### Compact wire mesh system

Space saving leaflet dispenser in three convenient sizes. The A4 variants come with dividers to convert them to 1/3A4. Finished in black powder coated wire mesh.

Capacity	4 x 1/3A4	Capacity	4 x A4 or 8 x 1/3A4	Capacity	1 x A4 or 2 x 1/3A4
Size	H 419mm W 133mm D 178mm	Size	H 457mm W 248mm D 165mm	Size	H 222mm W 248mm D 127mm
Code	<b>G5641BL</b>	Code	<b>G5640BL</b>	Code	<b>G5643BL</b>



G5640BL

## Mesh freestanding literature dispensers

### High capacity rotational dispenser

Three sided leaflet display finished in classic black powder coat. The carousel has 30 A4 overlapping pockets and rotates 360° as a single unit. Each pocket is 25mm deep giving this unit a considerable capacity.

Capacity 30 x A4  
 Size H 1680mm  
 W 420mm  
 D 420mm  
 Code **G5577BL**

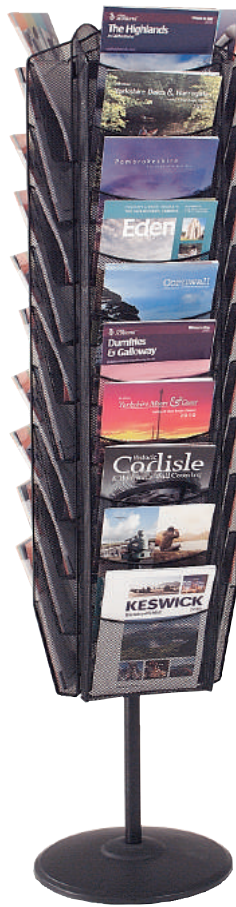

G6460BL

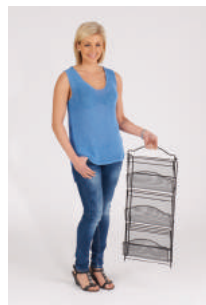

## Mesh floor racks

### Extra wide wire mesh floor racks

These floor racks are designed to take literature up to 310mm wide. Both of the 3 or 5 pocket models have large 45mm capacity pockets which are finished in black powder coated wire mesh. The subtle yet sturdy coated steel stand holds each pocket at the optimum visual angle. Folds flat for portability and storage.



G6461BL

**5 pocket floor rack**  
 Capacity 5 x 310mm wide pockets  
 Size H 1168mm  
 W 318mm  
 D 470mm  
 Code **G6461BL**

**3 pocket floor rack**  
 Capacity 3 x 310mm wide pockets  
 Size H 680mm  
 W 318mm  
 D 330mm  
 Code **G6460BL**

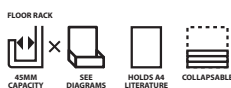
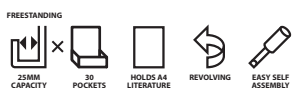

# Leaflet Display - Steel Mesh



G6455BL



G6452BL

**New Product**

## Mesh document racks

### Extra wide wire mesh document and folder racks

These wall or partition document organiser racks are designed to take literature up to 310mm wide. Both of the 1 or 3 pocket models have large 45mm capacity pockets which are finished in black powder coated wire mesh. The subtle yet sturdy coated steel rack holds each pocket at the optimum visual angle. Additional hanging brackets are included for fitting over a partition screen.

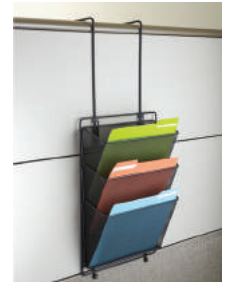

#### 1 pocket rack

Capacity 1 x 310mm wide pockets  
 Size H 248mm  
 W 337mm  
 D 102mm  
 Code **G6455BL**

#### 3 pocket rack

Capacity 3 x 310mm wide pockets  
 Size H 457mm  
 W 337mm  
 D 102mm  
 Code **G6452BL**

## Steel 7 pocket wall mounted rack

Ideal for holding oversize literature such as newspapers, folders and journals

Contemporary black coated steel rack that mounts to the wall. Holds 30mm of literature in each pocket. Simple wall fixings included. With open sides they are ideal for holding larger pieces of literature such as newspapers and magazines.



Capacity 30mm  
 Size H 552mm  
 W 241mm  
 D 50mm  
 Code **G3185BL**



EASY SELF ASSEMBLY



HOLDS A4 LITERATURE



MESH DOCUMENT RACKS  
 45MM CAPACITY  
 1 OR 3 POCKETS

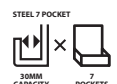

STEEL 7 POCKET  
 30MM CAPACITY  
 7 POCKETS



# Steel wall mounted literature dispensers

Sturdy wall mounted or freestanding display racks in black coated steel

This contemporary design allows the wall mounting of A4 literature in multiples of 5, 11 or 23 separate compartments. Mount either unit side by side for larger displays. Add the feet option to convert any unit to be freestanding. Each compartment holds 20mm of literature. Also available as revolving floor stands to match. Suitable for displaying brochures, magazines or within the manufacturing environment for works orders etc.



G4310BL



G4321BL



G4322BL



Capacity 5 x A4  
Size H 521mm  
W 254mm  
D 102mm  
Code **G4310BL**



Capacity 11 x A4  
Size H 921mm  
W 254mm  
D 102mm  
Code **G4321BL**



Capacity 23 x A4  
Size H 1664mm  
W 254mm  
D 102mm  
Code **G4322BL**



Feet  
Size H 133mm  
Footprint W 258mm  
D 356mm  
Code **G4323BL**

G4325BL



G4324BL



# Steel revolving literature dispensers

4 sided revolving floor stand in black coated steel

This sturdy design allows for a large amount of A4 literature to be displayed in either 44 or 92 separate compartments. Holds 20mm of literature in each. The unit rotates through 360° to allow for easy access to all sides. Ideal for displaying brochures, magazines or works orders.



Capacity 44 x A4  
Size H 1219mm  
W 356mm  
D 356mm  
Code **G4324BL**

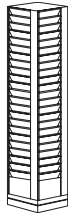

Capacity 92 x A4  
Size H 1727mm  
W 356mm  
D 356mm  
Code **G4325BL**

# Leaflet Display - Steel Wire

G6430BL



G6431BL



G6432BL



## Wire wall mounted literature dispensers

Simple and economical way to display your literature

Sturdy coated wire steel displays capable of retaining 55mm of literature in each holder. This range includes models that have 3, 5 or 7 holders for A4 literature. Finished in black powder coat and simply mounted by 2 keyhole fixing brackets.



Capacity 3 x A4  
Size H 495mm  
W 235mm  
D 165mm  
Code **G6430BL**



Capacity 5 x A4  
Size H 737mm  
W 235mm  
D 165mm  
Code **G6431BL**



Capacity 7 x A4  
Size H 978mm  
W 235mm  
D 165mm  
Code **G6432BL**

## Wire desktop literature dispenser

Economical way to display literature on your desktop

Sturdy coated wire steel displays capable of retaining up to 55mm of A4 literature in each of the 5 holders. The holders and stand are finished in black powder coating.

Capacity 5 x A4  
Size H 432mm  
W 248mm  
D 229mm  
Code **G6433BL**



# Wire revolving literature dispensers

## Rotary leaflet and brochure display

Four rotational tiers are mounted on a central column with each tier being able to rotate independently. The simple wire construction means that the full front of every leaflet/brochure is on full view. The leaflet model has 32 pockets to accommodate 1/3 A4 items and the brochure model has 16 x A4 pockets. Finished in black powder coat and mounted on five castors two of which are locking.



Capacity 32 x 1/3 A4  
 Size H 1524mm  
 W 381mm  
 D 381mm  
 Code **G4128CH**

Capacity 16 x A4  
 Size H 1524mm  
 W 381mm  
 D 381mm  
 Code **G4139CH**



G4139CH



G4128CH



# Wire mobile magazine rack

Five large shelves for brochures, magazines, catalogues and newspapers

The ideal way to display all types of brochures, magazines and catalogues. Five extra tall shelves for oversized publications. Finished in black powder coated wire, with tubular side frames. Mounted on four castors for mobility.

Capacity 15 x A4  
 Size H 1613mm  
 W 825mm  
 D 387mm  
 Code **G4129CH**

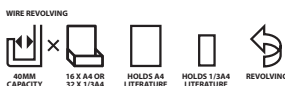
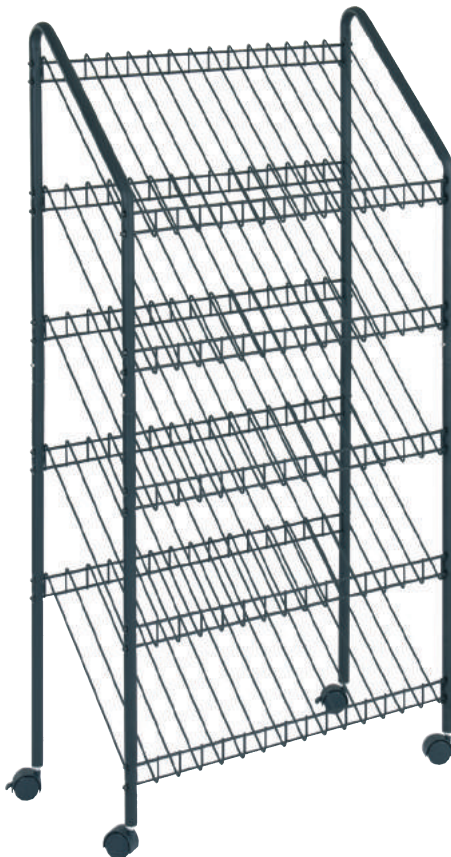

# Leaflet Display - Brochure Stackers



## A4 brochure stands

### Freestanding A4 brochure display

Present your brochure at the right height and angle in a clear deep pocket. The 70mm acrylic holder is mounted on a satin anodised aluminium column mounted on a stable base. Available in both landscape and portrait A4 formats.

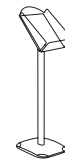

Capacity A4 Portrait  
 Size H 1000mm  
 W 250mm  
 D 330mm  
 Code **LD1077**



Capacity A4 Landscape  
 Size H 970mm  
 W 250mm  
 D 330mm  
 Code **LD1076**

## Brochure stacker

Ideal for holding a large volume of the same literature

This useful literature holder has a massive 275mm capacity to hold multiple copies of the same item. The 950mm high frame has an extremely robust design in silver coated steel. 2 wheels at the back aid mobility once loaded.



### Brochure stacker

Capacity 275mm  
 Size H 950mm  
 W 340mm  
 D 360mm  
 Code **LD4002**



# Exhibition and Display

- 148 - 151** BusyFold® Light Folding Systems
- 152 - 153** BusyFold® Heavy Duty Folding Systems
- 154** BusyFold® One Piece Folding Systems
- 155 - 157** MightyBoard Expandable Systems
- 158** OnBoard® Expandable Systems
- 159** Multi-Board Expandable Systems
- 160** Accessories
- 160** Colour Swatches



# NEW ColourPlus® vibrant colours

A new vibrant range of loop nylon colours have been introduced to our exhibition systems. Choose Purple, Cyan, Magenta, Apple, Orange and Lilac for a very contemporary display

## BusyFold® tabletop displays

- BusyFold® Light or BusyFold® Heavy Duty
- Landscape or portrait
- Folds into a carrying case supplied

## BusyFold® Light folding displays

- 8 x Standard 600 x 900mm panel size kits
- 8 x XL kits with larger 700 x 1000mm panels
- 3, 4, and 5 panel full height systems

## OnBoard® display systems

- Standard 600 x 900mm panel sizes
- 5 x Standard kits + extra components available
- Simple clip together pole and panel system

## BusyFold® heavy duty display systems

- Aluminium pinion edged system
- 7 x Standard 700 x 1000mm panel kits
- 2 x Tabletop units in landscape or portrait

## BusyFold® plinths

- 4 x Plinth kits for displaying 3D objects
- Aluminium pinion edged system
- White melamine platform

## MightyBoard display systems

- 11 x Pole and large panel system kits
- Locks together for a more permanent display
- Components available to create custom layouts

Colour  Plus



## BusyFold® Light landscape tabletop displays

Tabletop folding display systems are ideal for small presentations and displays, course work or exhibitions

Double sided panels fold down to 900 x 600mm or 1000 x 700mm for XL version. Panels accept Velcro®, BusyFix® (see accessories on page 160) or pins. Supplied with header panel. 14 Loop nylon colour options. Black or grey frame options. Storage bag with carrying handles and shoulder trap is included.

Dimensions - H x W	Standard	XL
Centre panel	600 x 900mm	700 x 1000mm
Side panels	600 x 450mm	700 x 500mm
Header panel	200 x 900mm	200 x 1000mm

### TO ORDER:

Please state the product code followed by the loop nylon fabric colour code required

EXAMPLE: BusyFold® Landscape Tabletop Display in apple with a grey frame = **BFTLG/AG**

### Standard

Size	H 800mm	W 1800mm
Weight	3kg	
Black frame	<b>BFTLB</b>	
Grey frame	<b>BFTLG</b>	

### XL

Size	H 900mm	W 2000mm
Weight	3.9kg	
Black frame	<b>BFXTLB</b>	
Grey frame	<b>BFXTLG</b>	



All tabletop systems come complete with carrying bag



BFTLB/RB



Headers are black on the reverse for personalising

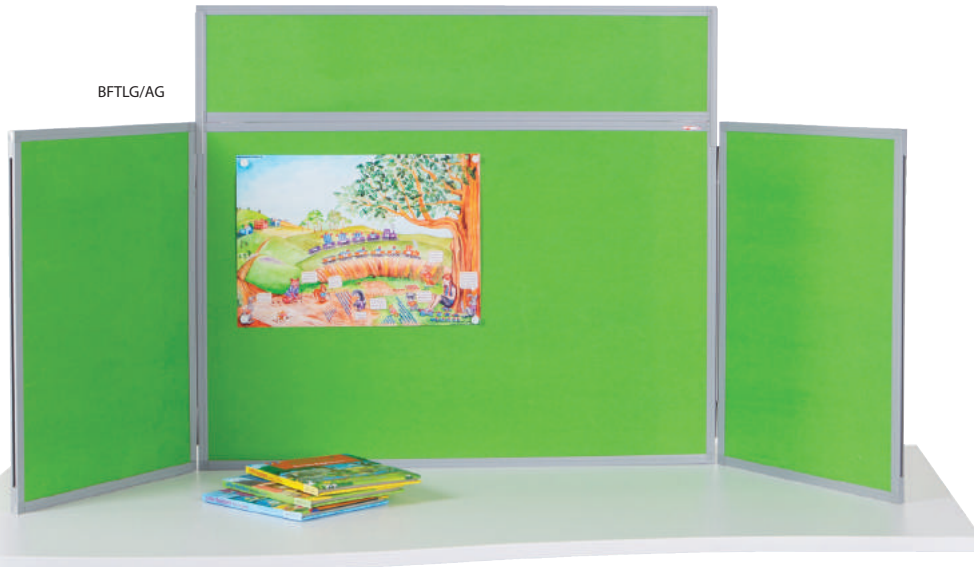

BFTLG/AG

### Loop nylon cloth - see page 160

#### Stock colours



### Non-stock colours - made to order

Please allow an extra 2-3 days



## BusyFold® Light portrait tabletop displays

### Tabletop folding display systems

Ideal for small presentations and displays, course work or exhibitions and fairs. Double sided panels fold down to 900 x 600mm or 1000 x 700mm for XL version. Panels accept Velcro®, BusyFix® (see accessories on page 160) or pins. Supplied with header panel. 14 Loop nylon colour options - see swatches. Black or grey frame options. Storage bag with carrying handles and shoulder trap is included.

Dimensions - H x W	Standard	XL
Centre panel	900 x 600mm	1000 x 700mm
Side panels	200 x 600mm	200 x 700mm

### TO ORDER:

Please state the product code followed by the loop nylon fabric colour code required

EXAMPLE: BusyFold® Portrait Tabletop in purple with a grey frame = **BFTPG/PU**

Headers are black on the reverse for personalising

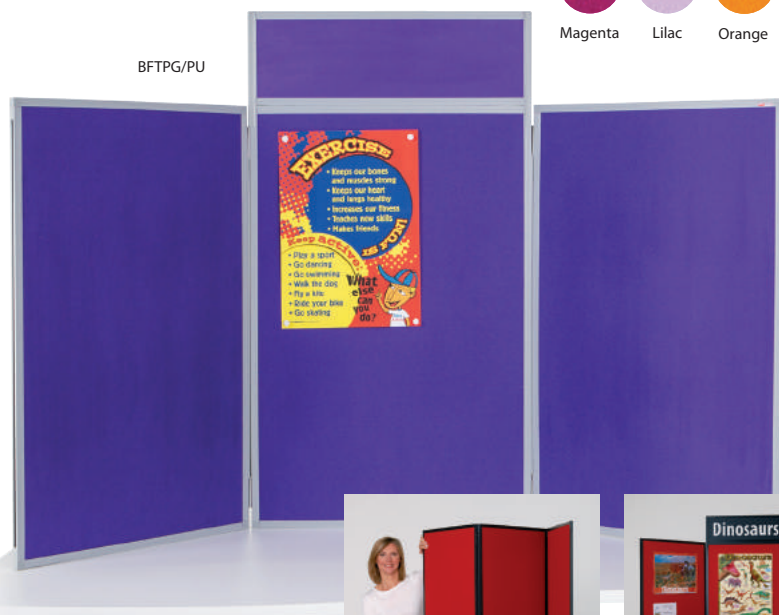

BFTPG/PU



BFTPB/AR



### Standard

Size	H 1100mm	W 1800mm
Weight	4kg	
Black frame	<b>BFTPB</b>	
Grey frame	<b>BFTPG</b>	

### XL

Size	H 1200mm	W 2100mm
Weight	5.2kg	
Black frame	<b>BFXTPB</b>	
Grey frame	<b>BFXTPG</b>	

# Exhibition Display - Folding Display

Headers are black on the reverse for personalising

BL6KG/CY

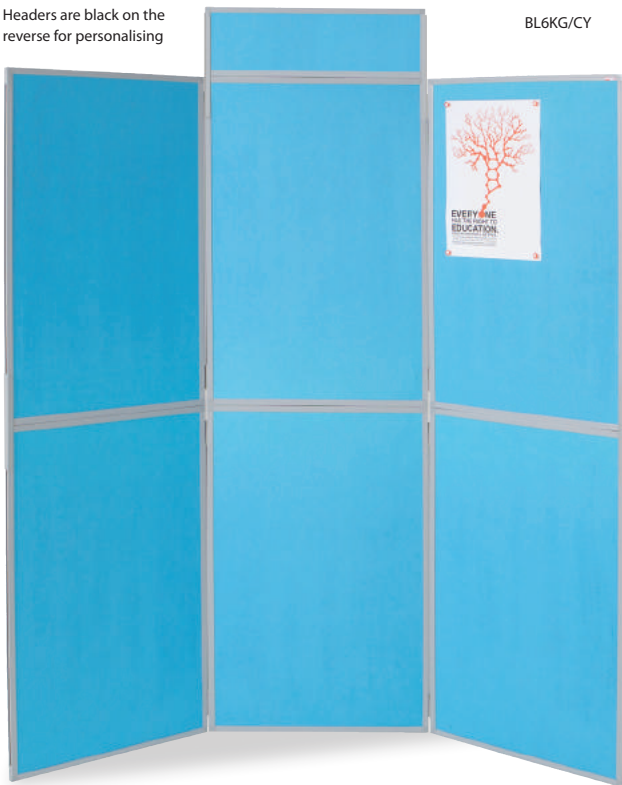

Loop nylon cloth - see page 160  
Stock colours



Extended range - made to order  
Please allow an extra 2-3 days

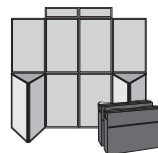
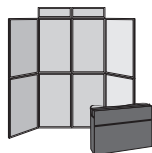
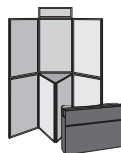
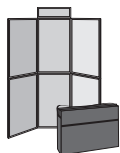

**BusyFold® Light Kits** Panel size 600 x 900mm

6 Panel + header

Size H 2000mm  
W 1800mm  
Weight 8.5kg  
Black frame **BL6KB**  
Grey frame **BL6KG**

7 Panel + header

Size H 2000mm  
W 1800mm  
Weight 13.7kg  
Black frame **BL7KB**  
Grey frame **BL7KG**

8 Panel + 2 headers

Size H 2000mm  
W 2400mm  
Weight 11kg  
Black frame **BL8KB**  
Grey frame **BL8KG**

10 Panel + 2 headers

Size H 2000mm  
W 2400mm  
Weight 24kg  
Black frame **BL10KB**  
Grey frame **BL10KG**

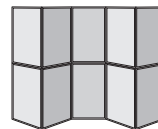
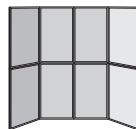

**BusyFold® Light** Panel size 600 x 900mm

6 Panel system

Size H 1800mm  
W 1800mm  
Weight 7.5kg  
Black frame **BL6B**  
Grey frame **BL6G**

7 Panel system

Size H 1800mm  
W 1800mm  
Weight 12.7kg  
Black frame **BL7B**  
Grey frame **BL7G**

8 Panel system

Size H 1800mm  
W 2400mm  
Weight 9.7kg  
Black frame **BL8B**  
Grey frame **BL8G**

10 Panel system

Size H 1800mm  
W 3000mm  
Weight 12.13kg  
Black frame **BL10B**  
Grey frame **BL10G**

## BusyFold® Light folding display systems

These popular lightweight display systems are now available with black or grey trim

Lightweight folding panel system – a six panel system weighs only 7.5kg. 600 x 900mm panels are PVC framed in a choice of black or grey. Top and bottom panels are linked with flexible hinging, and clip on top of each other for easy assembly. Available in a 6, 7, 8 and 10 panel configuration with a range optional carry bags and header panels. All panels are double sided with a choice of loop nylon covering which accepts Velcro® or BusyFix® and pins. Loop nylon fabric is fire retardant to BS5867. For BusyFix®, spot lights and other accessories see page 160.

### BusyFold® Light Kits

These 4 units are supplied complete with headers and carrying bags. The 7 panel and 10 panel units also include top/s for displaying 3D objects, monitors etc.

### TO ORDER:

Please state the product code followed by the loop nylon fabric colour code required

EXAMPLE:

6 panel system kit in cyan with grey frame = **BL6KG/CY**

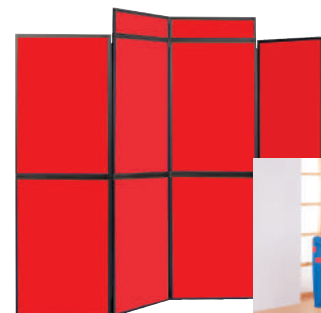

BL8KB/AR



### Header

Size H 200mm  
W 600mm  
Black frame **BLHB**  
Grey frame **BLHG**

### Bags

To Fit  
6 panel system **DB1020**  
7 panel system **DB1021**  
8 panel system **DB1021**  
10 panel system **DB1022**



## BusyFold® Light XL folding display systems

BusyFold® Light with a larger 1000 x 700mm panel size

Still lightweight, the six panel system weighs only 9.5kg making it still very portable. These popular lightweight display systems are also available with PVC framing in a choice of black or grey. Top and bottom panels are linked with flexible hinging and clip on top of each other for easy assembly. Available in a 6, 7, 8 and 10 panel configurations with a range optional carry bags and header panels. All panels are double sided with a choice of loop nylon covering which accepts Velcro® or BusyFix® and pins. Loop nylon fabric is fire retardant to BS5867. For BusyFix®, spot lights and other accessories see page 160.

### BusyFold® Light XL Kits

These 4 units are supplied complete with headers and carrying bags. The 7 panel and 10 panel units also include top/s for displaying 3D objects, monitors etc.

### TO ORDER:

Please state the product code followed by the loop nylon fabric colour code required

### EXAMPLE:

8 panel system with black frame in royal blue = **BLX8B/RB**

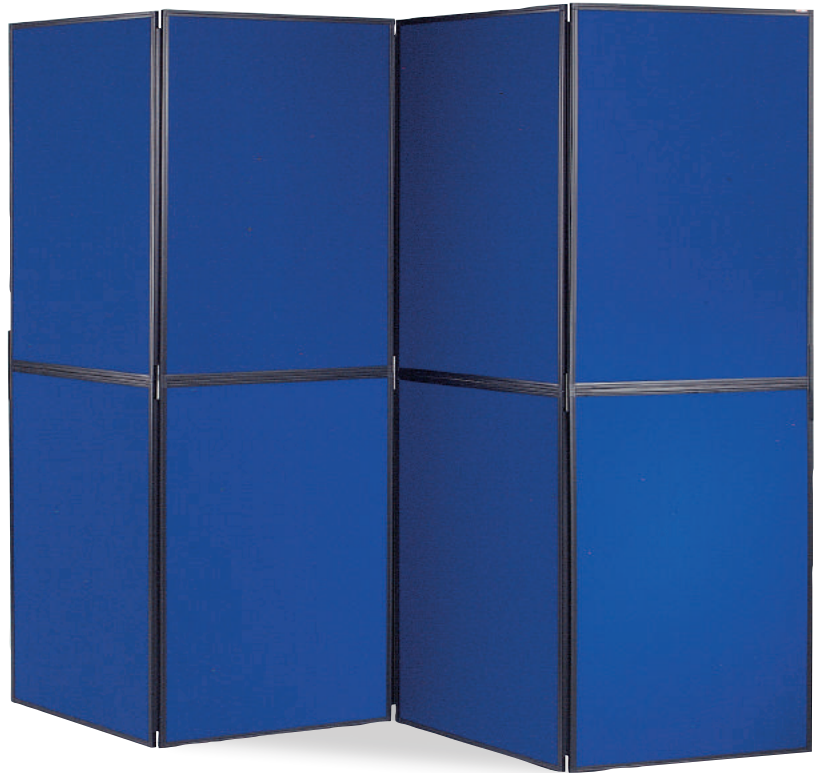

Loop nylon cloth - see page 160  
Stock colours



Extended range - made to order  
Please allow an extra 2-3 days



BLX8B/RB



Headers are black on the reverse for personalising

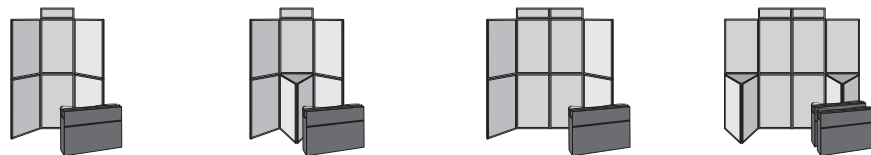

BusyFold® Light XL Kits Panel size 700 x 1000mm

6 Panel XL + header		7 Panel XL + header		8 Panel XL + 2 headers		10 Panel XL + 2 headers	
Size	H 2200mm W 2100mm	Size	H 2200mm W 2100mm	Size	H 2200mm W 2800mm	Size	H 2200mm W 2800mm
Weight	10.5kg	Weight	17.5kg	Weight	14kg	Weight	27kg
Black frame	<b>BLX6KB</b>	Black frame	<b>BLX7KB</b>	Black frame	<b>BLX8KB</b>	Black frame	<b>BLX10KB</b>
Grey frame	<b>BLX6KG</b>	Grey frame	<b>BLX7KG</b>	Grey frame	<b>BLX8KG</b>	Grey frame	<b>BLX10KG</b>



BusyFold® Light XL Panel size 700 x 1000mm

6 Panel XL system		7 Panel XL system		8 Panel XL system		10 Panel XL system	
Size	H 2000mm W 2100mm	Size	H 2000mm W 2100mm	Size	H 2000mm W 2800mm	Size	H 2000mm W 3500mm
Weight	9.5kg	Weight	16.5kg	Weight	12.6kg	Weight	18.8kg
Black frame	<b>BLX6B</b>	Black frame	<b>BLX7B</b>	Black frame	<b>BLX8B</b>	Black frame	<b>BLX10B</b>
Grey frame	<b>BLX6G</b>	Grey frame	<b>BLX7G</b>	Grey frame	<b>BLX8G</b>	Grey frame	<b>BLX10G</b>

Header	
Size	H 200mm W 700mm
Black frame	<b>BLXHB</b>
Grey frame	<b>BLXHG</b>

Bags	
To Fit	
6 panel system	<b>DB1020</b>
7 panel system	<b>DB1021</b>
8 panel system	<b>DB1021</b>
10 panel system	<b>DB1022</b>

# Exhibition Display - Folding Display

Headers are black on the reverse for personalising

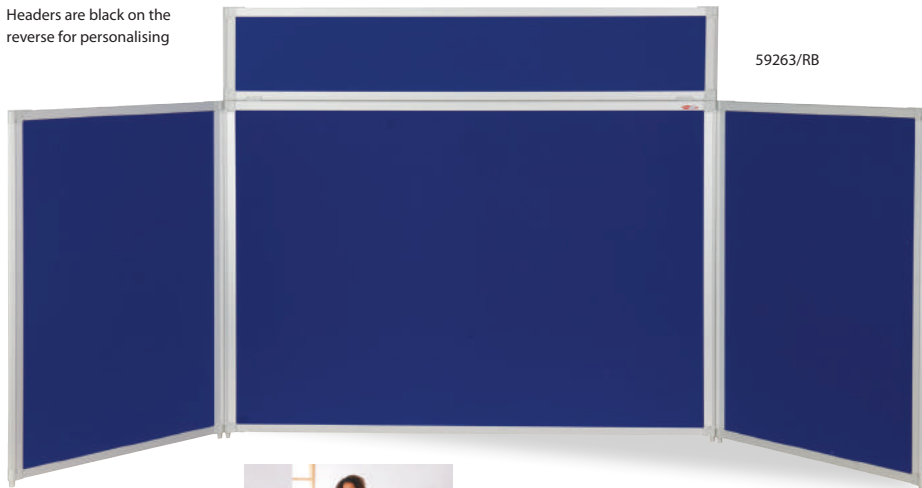

59263/RB



All tabletop systems come complete with carrying bag

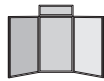

Size H 1200mm  
W 2100mm  
Code **59264**

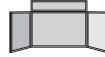

Size H 900mm  
W 2000mm  
Code **59263**

## BusyFold® heavy duty tabletop displays

Aluminium framed display system for extra durability

Robust aluminium framed panels; with interlocking gear hinge mechanism creates a very professional display system. The double sided panels are available in a choice of 14 loop nylon finishes, 4 supplied from stock. Supplied with header panel which has loop nylon fabric on one side and black on reverse for optional personalising. Storage bag with carrying handles and shoulder strap is included. For BusyFix®, spot lights and other accessories see page 160.

Dimensions	H x W	
<b>Portrait</b>	All 3 panels	1000 x 700mm
	Header panel	200 x 700mm
<b>Landscape</b>	Centre panel	685 x 1010 mm
	Side panels	685 x 505 mm
	Header panel	190 x 1010 mm

**TO ORDER:**

Please state the product code followed by the loop nylon fabric colour code required.

EXAMPLE:

BusyFold® Heavy Duty tabletop landscape in royal blue = **59263/RB**

## BusyFold® heavy duty display plinths

Add a third dimension to your display with these folding plinths

Enhance the folding display system with these matching aluminium folding plinths. Same interlocking gear hinge mechanism make this a superb, robust and safe system. The white platforms secure the folding panels into position. Extra storage for catalogues, coats etc is achieved as 1 of the panels hinges open, to create a useful cupboard. The rigid double sided panels are available in 14 loop nylon finishes to match the display systems.

**TO ORDER:**

Please state the product code followed by the loop nylon fabric colour code required

EXAMPLE:

BusyFold® 1000 x 350mm plinth in alfa red loop nylon = **PL1035/AR**



PL1070/LG



PL1035/AR

PL5070/EG



PL5035/RB

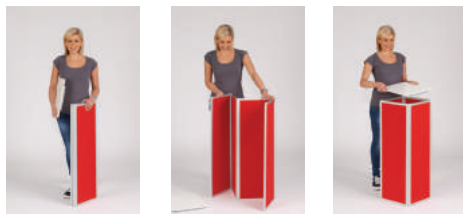

Size H 500mm  
W 350mm  
D 350mm  
Weight 4.5kg  
Code **PL5035**

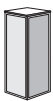

Size H 1000mm  
W 350mm  
D 350mm  
Weight 7.1kg  
Code **PL1035**



Size H 500mm  
W 700mm  
D 700mm  
Weight 9kg  
Code **PL5070**

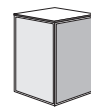

Size H 1000mm  
W 700mm  
D 700mm  
Weight 12.5kg  
Code **PL1070**

Loop nylon cloth - see page 160

<b>RB</b> Royal Blue	<b>AR</b> Alfa Red	<b>EG</b> Emerald Green	<b>TW</b> Twin Colour Blue/Grey
<b>LB</b> Light Blue	<b>YL</b> Yellow	<b>BU</b> Burgundy	<b>BK</b> Black
<b>PU</b> Purple	<b>MG</b> Magenta	<b>LC</b> Lilac	<b>OR</b> Orange
<b>AG</b> Apple	<b>CY</b> Cyan		

## BusyFold® heavy duty display systems

### The ultimate folding display system

Aluminium framing, interlocking gear hinge mechanism and a secure panel locking system make this a superb, robust and safe system. The upper set of panels lock securely onto the lower set, preventing them from toppling over, even when repositioning the display. The interlocking hinge prevents daylight showing between the panels. The rigid double sided panels are a generous 700 x 1000mm and available in a choice of 14 loop nylon finishes. A wide range of accessories are available including linked headers for easy assembly. The 7 panel units come with a triangular shelf for displaying 3D objects, monitors etc. For BusyFix®, spot lights and other accessories see page 160.

### BusyFold® HD Kits

These 3 units are supplied complete with headers and carrying bags.

### TO ORDER:

Please state the product code followed by the loop nylon fabric colour code required

### EXAMPLE:

BusyFold® Heavy Duty 6 panel in alfa red = **59265/AR**

59265/AR +  
59277/AR

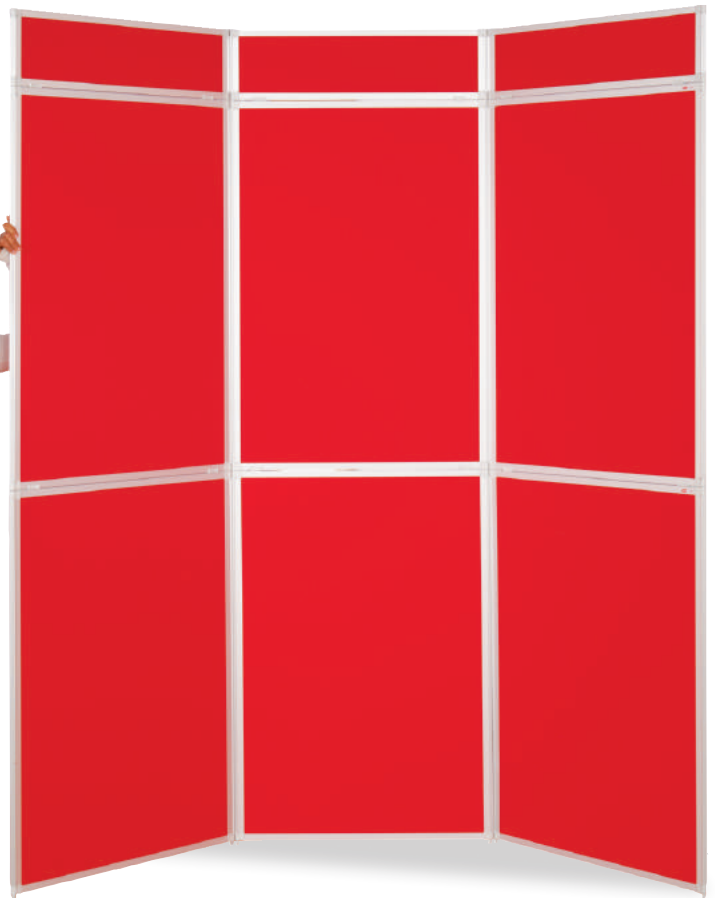

Headers are black on the reverse for personalising

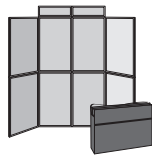
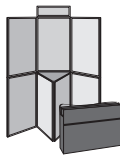
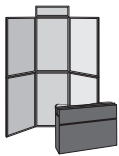

Both halves lock securely to each other

Loop nylon cloth - see page 160

### Stock colours



### Extended range - made to order

Please allow an extra 2-3 days



### BusyFold® Light Kits Panel size 600 x 900mm

#### 6 Panel + header

Size H 2200mm  
W 2100mm  
Weight 16kg  
Code **59265K**

#### 7 Panel + header

Size H 2200mm  
W 2100mm  
Weight 20kg  
Code **59268K**

#### 8 Panel + 2 headers

Size H 2200mm  
W 2800mm  
Weight 19.5kg  
Code **59271K**

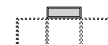
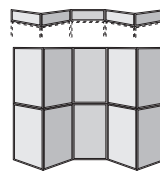
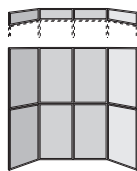
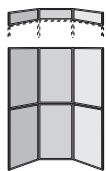

### BusyFold® HD Panel size 900 x 1000mm

#### 6 Panel system

Size H 2000mm  
W 2100mm  
Weight 15kg  
System **59265**  
Carry Bag **DB1020**  
Linked Header **59277**

#### 7 Panel system

Size H 2000mm  
W 2100mm  
Weight 19kg  
System **59268**  
Carry Bag **DB1021**  
Linked Header **59277**

#### 8 Panel system

Size H 2000mm  
W 2800mm  
Weight 18.5kg  
System **59271**  
Carry Bag **DB1021**  
Linked Header **59280**

#### 10 Panel system

Size H 2000mm  
W 3500mm  
Weight 23kg  
System **59274**  
Carry Bag **DB1022**  
Linked Header **59283**

#### Header

Size H 200mm  
W 700mm  
Single Header **59286**

#### Bags

To Fit  
6 panel system **DB1020**  
7 panel system **DB1021**  
8 panel system **DB1021**  
10 panel system **DB1022**



# Exhibition Display - One Piece Folding Display



BL4KG/MG

## BusyFold® Light 1800 folding display systems

Full height system with no horizontal joins

When your display needs a taller uninterrupted visual area, then BusyFold® Light 1800 is the most economical choice. Each panel is 600mm wide but is a full 1800mm high, therefore eliminating the central join. Each panel is joined by a full length flexible hinge and can fold against each other for easy storage. Available in a 3, 4 and 5 panel configuration with optional header panels. All panels are double sided with a choice of loop nylon covering, which accepts Velcro® or BusyFix® (see page 160) as well as pins. Black or grey trim available.

### TO ORDER:

Please state the product code followed by the loop nylon fabric colour code required (colours as above)  
EXAMPLE:

BusyFold® 1800 5 panel in royal blue = **BL5K/RB**

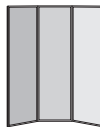

### 3 Panel system

Size H 1800mm  
W 1800mm

Weight 7.8kg  
Black **BL3KB**  
Grey **BL3KG**

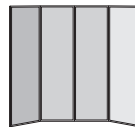

### 4 Panel system

Size H 1800mm  
W 2400mm

Weight 9.7kg  
Black **BL4KB**  
Grey **BL4KG**

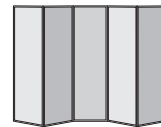

### 5 Panel system

Size H 1800mm  
W 3000mm

Weight 12.1kg  
Black **BL5KB**  
Grey **BL5KG**

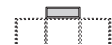

### Header

Size H 200mm  
W 600mm

Black **BLHB**  
Grey **BLHG**  
Accessory Bag **DB1060**



Loop nylon cloth colours - see page 160



FOR ALL DISPLAY SYSTEM ACCESSORIES - SEE PAGE 160



MBKE/TW

## MightyBoard exhibitor system

### Large portable display system

The MightyBoard Exhibitor is portable thanks to its split pole design and compact panel size, enabling the system to be loaded into a car. All components are fully interchangeable with MightyBoard Display, giving great flexibility.

The panels lock firmly into position, to create a very safe structure. The most popular configurations are listed below, however see page 157 if you wish to create your own layout. High impact PVC framed panels are double sided with a choice of eight loop nylon coverings which accept pins, Velcro® and BusyFix®. For BusyFix®, spot lights and other accessories see page 160.

### TO ORDER:

Please state the product code followed by the loop nylon fabric colour code required

### EXAMPLE:

MightyBoard Kit E in twin colour, blue and grey = **MBKE/TW**



#### Kit A

Panels 4 panels  
 Headers 2 headers  
 Size H 2000mm  
 W 1800mm  
 Code **MBKA**



#### Kit B

Panels 4 panels  
 Headers 2 headers  
 Size H 2000mm  
 W 2400mm  
 Code **MBKB**

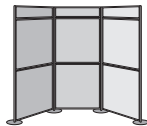

#### Kit C

Panels 6 panels  
 Headers 3 headers  
 Size H 2000mm  
 W 2700mm  
 Code **MBKC**

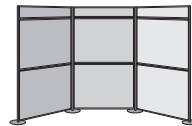

#### Kit D

Panels 6 panels  
 Headers 3 headers  
 Size H 2000mm  
 W 3600mm  
 Code **MBKD**

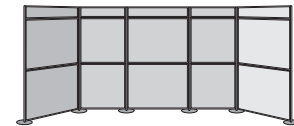

#### Kit E

Panels 10 panels  
 Headers 5 headers  
 Size H 2000mm  
 W 5400mm  
 Code **MBKE**



### Loop nylon cloth - see page 160



# Exhibition Display - Pole and Panel



## MightyBoard display system

### When you want to create a big semi-permanent display

MightyBoard is true to its name, offering our largest display panel size of up to 1800 x 1200mm. Mounted onto a substantial pole and base system, MightyBoard Display panels enable you to exhibit large displays that other systems would fail to accommodate.

The modular design enables the system to be extended at any point in time. The most popular configurations are listed below, however see the opposite page if you wish to create your own layout. High impact PVC framed panels are double sided with a choice of 14 loop nylon coverings, which accept pins and Velcro® or BusyFix®, for BusyFix®, spot lights and other accessories see page 160.

### TO ORDER:

Please state the product code followed by the loop nylon fabric colour code required

### EXAMPLE:

MightyBoard Display Kit H in royal blue = **MBKH/RB**

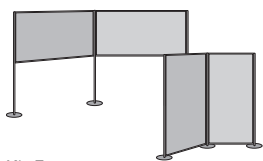

**Kit F**  
Panels 2 panels  
Height 1800mm  
Size H 900mm  
W 3600mm

OR  
Size H 1800mm  
W 1800mm

Code **MBKF**

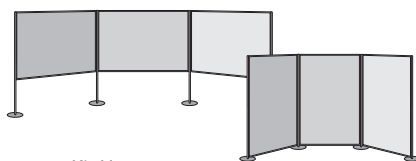

**Kit H**  
Panels 3 panels  
Height 1800mm  
Size H 1200mm  
W 5400mm

OR  
Size H 1800mm  
W 3600mm

Code **MBKH**

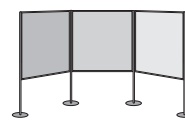

**Kit G**  
Panels 3 panels  
Height 1800mm  
Size H 1200mm  
W 3600mm

Code **MBKG**

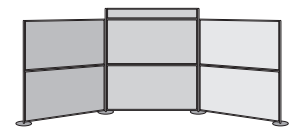

**Kit I**  
Panels 6 panels  
Height 2000mm (inc header)  
Headers 1 header  
Size H 1800mm  
W 5400mm

Code **MBKI**

**Loop nylon cloth colours -**  
see page 160

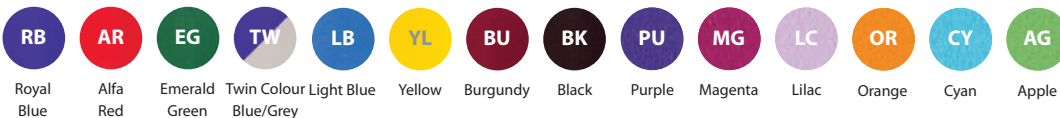

MBKG/AG



# Design your own Mightyboard - Exhibition Display



## MightyBoard components

Components sold individually to create your own or extend your existing system

Due to its consistent interchangeable design, you can extend, replace or change the colour scheme of your system with ease. Create your very own layout using the standard components, remembering that you can add and reconfigure at any time. For BusyFix®, spot lights and other accessories see page 160.

### TO ORDER:

For panels and headers please state the product code followed by the loop nylon fabric colour code required

### EXAMPLE:

MightyBoard 900 X 900mm panel in royal blue = **49204N/RB**



<b>Panel</b> Size H 900mm W 900mm Weight 2.18kg Code <b>49204N</b>	<b>Panel</b> Size H 900mm W 1200mm Weight 2.9kg Code <b>49205N</b>	<b>Panel</b> Size H 900mm W 1800mm Weight 4.35kg Code <b>49207N</b>	<b>Panel</b> Size H 1200mm W 1200mm Weight 3.87kg Code <b>49208N</b>	<b>Panel</b> Size H 1200mm W 1800mm Weight 5.8kg Code <b>49209N</b>	
<b>Header</b> Size H 200mm W 900mm Weight 0.48kg Code <b>49211N</b>	<b>Header</b> Size H 200mm W 1200mm Weight 0.64kg Code <b>49212N</b>	<b>Header</b> Size H 200mm W 1800mm Weight 0.97kg Code <b>49213N</b>	<b>Pole</b> standard pole including base Size L 1800mm Weight 3.5kg Code <b>49214N</b>	<b>Pole</b> split pole including base Size L 2 x 900mm Weight 3.5kg Code <b>49218N</b>	<b>Pole</b> header extension pole Size L 200mm Weight 0.6kg Code <b>49215N</b>

Loop nylon cloth colours - see page 160

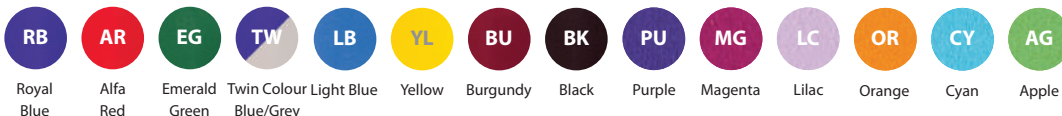

# Exhibition Display - Pole and Panel



880008/MG

## OnBoard® expandable display systems

### Easily extend and reconfigure this flexible system

A lightweight pole and panel system that, due to its modular design, enables the user to reconfigure and extend the display system to meet the application. Standard 600 x 900mm panels can be mounted both portrait or landscape on to the 1800mm high pole using C clips provided. The system can be extended at any point in the future by purchasing another kit to link on. Available with black or grey framework.

Combine with a large range of 14 loop nylon colours. All panels are double sided with a choice of loop nylon covering which accepts Velcro®, BusyFix® and pins. Header panels have loop nylon fabric on one side and black on reverse for optional personalising.

**TO ORDER:** Please state the product code followed by the loop nylon fabric colour code required  
**EXAMPLE:**  
 OnBoard® 8 panel in magenta with grey frame  
 = **880008/MG**

**Loop nylon cloth** - see page 160  
**Stock colours**



**Extended range - made to order**  
 Please allow an extra 2-3 days



#### 6 Panel + header

Size H 2000mm  
 W 2100mm  
 Weight 9.5kg  
 Black frame **880001**  
 Grey frame **880002**



#### 6 Panel

Size H 1800mm  
 W 1800mm  
 Weight 9kg  
 Black frame **880003**  
 Grey frame **880004**



#### 7 Panel

Size H 1800mm  
 W 1800mm  
 Weight 10kg  
 Black frame **880005**  
 Grey frame **880006**



#### 8 Panel

Size H 1800mm  
 W 2400mm  
 Weight 10.5kg  
 Black frame **880007**  
 Grey frame **880008**



#### 10 Panel

Size H 1800mm  
 W 3000mm  
 Weight 14.5kg  
 Black frame **880009**  
 Grey frame **880010**

Headers are black on the reverse for personalising

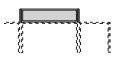

#### Header set

Size H 200mm  
 W 600mm  
 Black frame **880013**  
 Grey frame **880016**

#### Header set

Size H 200mm  
 W 900mm  
 Black frame **880014**  
 Grey frame **880017**



#### Panel

Size H 900mm  
 W 600mm  
 Black frame **880012**  
 Grey frame **880018**



#### Pole set

Black **880015**  
 Grey **880019**

#### Bags

To Fit  
 6 panel system **DB1020**  
 7 panel system **DB1021**  
 8 panel system **DB1021**  
 10 panel system **DB1022**



FOR ALL DISPLAY SYSTEM ACCESSORIES - SEE PAGE 160

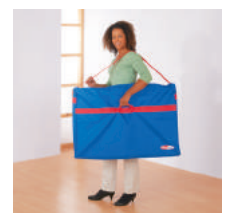



## Multi-Board mobile presentation system

An exhibition and display system with multitude of uses - artwork display, photography, large format drawings

Whiteboard variants are ideal for brainstorming, interactive sessions and presentations. Large aluminium framed panel measuring 1500(H) x 1200mm(W) that mounts portrait or landscape between sturdy steel legs. Total height of 1950mm when mounted either portrait or landscape. Supplied with adjustable button feet for stable positioning, castor sets are available to make the boards mobile. Can be used in straight line or curved arcs due to unique angled feet. 6 panels create a semi circle, 12 panels a complete circle; ideal for large display events in school halls or entrances. Foot joining plates supplied to lock adjacent panels together. Robust construction will give years of trouble free use.

**Available in 2 options:**

- A Double sided fabric covered pinnable display system.
- B One side pinnable fabric and one side magnetic whiteboard with pen tray and flipchart clips.

Both systems are interchangeable for greater flexibility.

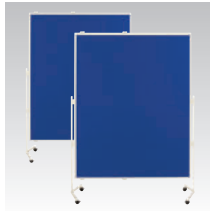

**Pinnable System**

Both sides are fabric covered and accepts pins.

Blue /Blue  
Code **79101**



**Pin and Write System**

One side fabric covered and one side magnetic whiteboard.

Blue /Whiteboard  
Code **79102**



**Castor Feet**

2 locking  
Available to fit both models.

Set of 4 **79201**

**Easy mounting**



**Joining plates**



**Pen tray**



**Flip pad clips**



79101

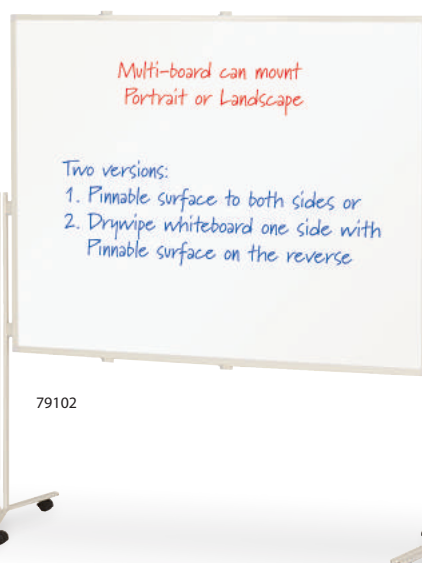

79102



# Exhibition Display - Colour Swatches and Accessories

## Exhibition system loop nylon fabric colours

### BusyFold® - MightyBoard - OnBoard®

The loop nylon range is pinnable and also accepts Velcro®, now with the addition of 6 extra vibrant colourways



### Spot lights

240v 50w hi-spot light on 400mm arm. Finished in silver finish with 4000mm cable. Mounts to any display system.

Code **AL3000**



### BusyFix® coins

20mm diameter self adhesive coins for attaching artwork to loop nylon panels.

Pack of 100 **45120**  
Pack of 1000 **45BR**



### Transporter

Handy trolley for effortlessly transporting large or multiple display systems

Code **GPT90**



### Leaflet holder

Clear acrylic holder attaches with Velcro fasteners to any loop nylon panel.

A4 **LD1005**  
A5 **LD1006**  
1/3A4 **LD1007**

# BusyScreen® Partitions

- 162 - 163 BusyScreen® Curve
- 164 - 165 BusyScreen® Classic
- 166 BusyScreen® Triple Safety
- 167 BusyScreen® Accessories
- 168 - 169 BusyScreen® Carnival
- 170 - 171 BusyScreen® Connect
- 172 - 173 Colour Swatches
- 174 Barriers



# BusyScreen® Partitions - Curve



## BusyScreen® Curve floor divider screens

- 32mm thick partition screens
- Rounded upper corners and a rounded edge trim
- 2 stabilising feet per panel
- Optional castor feet for mobility

Available in a large selection of Woven or Loop Nylon colourways, see pages 172-173 for material information. A range of 11 sizes in 5 height options. The foot design prevents twisting and fits securely into the base of each screen. Optional castor feet available in lieu of stabiliser feet.

### TO ORDER:

Please state the product code followed by the fabric colour code required - see opposite page

### EXAMPLE:

Divider screen 1600 x 1200mm in magenta = **BA1612/MG**



Height 900mm  
Width 1000mm **BA9010**



Height 1200mm  
Width 1000mm **BA1210**  
1200mm **BA1212**  
1600mm **BA1216**

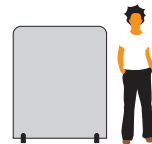

Height 1450mm  
Width 1200mm **BA1412**



Height 1600mm  
Width 1000mm **BA1610**  
1200mm **BA1612**  
1600mm **BA1616**

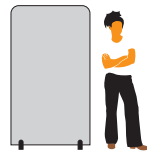

Height 1800mm  
Width 1000mm **BA1810**  
1200mm **BA1812**  
1600mm **BA1816**

Castor Feet  
Supplied in lieu of stabiliser feet  
Code **BS73382**

### Safe Curve corner design



### Stabiliser feet supplied

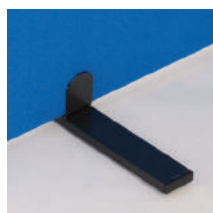



## BusyScreen® Curve desk screens

- 400mm high to attach to the edge of work desks
- 32mm thick pinnable partition screens
- Rounded upper corners and a rounded edge trim
- A pair of clamps or brackets required for each screen



Available in a large selection of Woven or Loop Nylon colourways, see pages 172-173. The 400mm high screens are available in a range of 6 lengths. Choose a pair of clamps or brackets per panel, depending on desk thickness, to fit securely into the base of each screen.

**TO ORDER:**

Please state the product code followed by the fabric colour code required

**EXAMPLE:**

Desk screen 1800mm wide in royal blue = **BA4018/RV**

**Height 400mm**

Width

- 800mm **BA4080**
- 1000mm **BA4010**
- 1200mm **BA4012**
- 1400mm **BA4014**
- 1600mm **BA4016**
- 1800mm **BA4018**



**Pair of clamps**

Fits desks between 12-30mm thick.

Code **BS00223**



**Pair of brackets**

Fits desks over 30mm thick.

Code **BS71445**

**Woven cloth colours with black trim** - see page 173



**Traditional loop nylon cloth colours supplied with black trim** - see page 172



**New loop nylon cloth colours with grey trim** - see page 172



Accessories see page 167

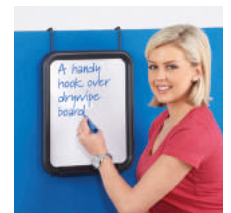

# BusyScreen® Partitions - Classic



## BusyScreen® Classic floor partition systems

- Flexible linking strip for joining screens together
- Flat or Curved screen options
- 32mm thick partition screens
- Optional castor feet for mobility

Display, divide and partition with one standard product. 32mm thick to provide an excellent acoustic shadow. Available in a large selection of Woven or Loop Nylon colourways, see pages 172-173. Each screen is supplied with a pair of stabilising feet, height adjustable button feet and a flexible linking strip. Available in a choice of 3 different heights and up to 6 different widths. Curved screens are supplied with button feet only and are intended for use adjoining other screens and should not be used stand alone.

### TO ORDER:

Please state the product code followed by the fabric colour code required - see opposite page  
EXAMPLE:

Flat floor screen 1525 x 1200mm in scarlet = **BB1512/SC**



Height 1225mm  
Width  
900mm **BB1290**  
1000mm **BB1210**  
1200mm **BB1212**  
1500mm **BB1215**  
1600mm **BB1216**  
1800mm **BB1218**



Height 1525mm  
Width  
900mm **BB1590**  
1000mm **BB1510**  
1200mm **BB1512**  
1500mm\* **BB1515**  
1600mm\* **BB1516**  
1800mm\* **BB1518**

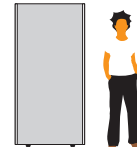

Height 1825mm  
Width  
900mm **BB1890**  
1000mm **BB1810**  
1200mm **BB1812**  
1500mm\* **BB1815**  
1600mm\* **BB1816**

\*sizes shown in RED only available in Woven Cloth

### Curved Floor Partitions

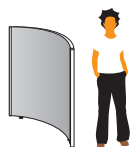

Height 1225mm  
Width  
1131mm **CB1211**



Height 1525mm  
Width  
1131mm **CB1511**

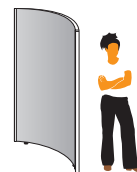

Height 1825mm  
Width  
1131mm **CB1811**

### Flexible linking strip





## BusyScreen® Classic desk partitions

- Straight desk screens measure 400mm deep
- Wave desk screens measure 400 to 600mm deep
- A pair of clamps or brackets required for each screen
- 32mm thick partition screens

Available in both wave and straight topped versions. Two brackets are required per screen, choose from clamp style suitable for most desks, or screw on bracket for thicker tops or where under frames cause an obstruction. Available in a large selection of Woven or Loop Nylon colourways, see pages 172-173.

### TO ORDER:

Please state the product code followed by the fabric colour code required.

EXAMPLE:

Straight desk screen 800mm in royal blue = **BB4080/Ry**

### Straight Top Desk Partitions



Height 400mm

Width	Code
800mm	<b>BB4080</b>
1000mm	<b>BB4010</b>
1200mm	<b>BB4012</b>
1400mm	<b>BB4014</b>
1600mm	<b>BB4016</b>
1800mm	<b>BB4018</b>

### Wave Top Desk Partitions

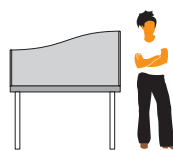

Height 400-600mm

Width	Code
800mm	<b>BB6480</b>
1000mm	<b>BB6410</b>
1200mm	<b>BB6412</b>
1400mm	<b>BB6414</b>
1600mm	<b>BB6416</b>
1800mm	<b>BB6418</b>



Pair of clamps  
Fits desks between  
12-30mm thick.  
Code **BS00223**

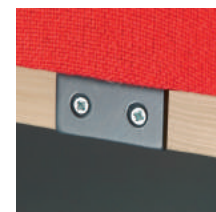

Pair of brackets  
Fits desks over  
30mm thick.  
Code **BS71445**

### Woven cloth colours with black trim - see page 173



### Traditional loop nylon cloth colours supplied with black trim - see page 172



### New loop nylon cloth colours with grey trim - see page 172



Accessories see page 167

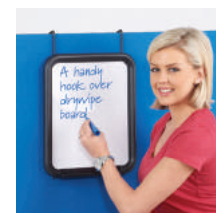

# BusyScreen® Partitions - Triple Safety



**New Colours**

## BusyScreen® Classic triple safety set

- Mobile set of 3 screens with locking castor feet
- Remove links to stack the screens for storage
- Range of 3 popular heights
- 29 colour options in woven or loop nylon

This popular mobile triple screen set is supplied with two way linking strips and castor feet; giving maximum safety and mobility. The linking strips are easily removed to enable the screens to be stacked together for compact storage. Choose from three popular screen heights and a wide range of fabric options. Woven cloths are traditional and hardwearing whilst loop nylon has the advantage of being Velcro® friendly. Panels are supplied with grey or black trim as indicated below, unless specified.

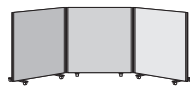

Panels 3 panels  
Size H 1225mm  
W 1200mm  
Code **TSS4**

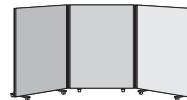

Panels 3 panels  
Size H 1525mm  
W 1200mm  
Code **TSS3**

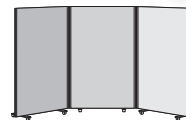

Panels 3 panels  
Size H 1825mm  
W 1200mm  
Code **TSS1**

Please state the product code followed by the woven or loop nylon fabric colour code required  
EXAMPLE: 1525 x 1200mm BusyScreen® Triple Safety Set in magenta loop nylon cloth = **TSS3/MG**

### Woven cloth colours with black trim - see page 173



### Traditional loop nylon cloth colours supplied with black trim - see page 172



### New loop nylon cloth colours with grey trim - see page 172





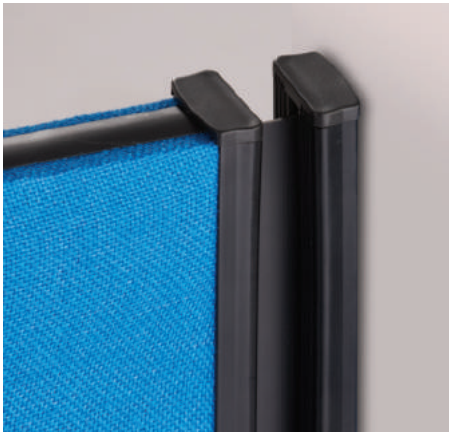

## Wall linking batten

For joining one end of a BusyScreen® to a wall

Curve Not available  
 Classic **RMA8**  
 Carnival **RMA10**  
 Connect **RMA11**



## Castor feet

In lieu of standard feet. Not for use with curved screens

Curve **BS73382**  
 Classic **RMA9**  
 Carnival **BS73382**  
 Connect Not available



## Hook over whiteboard

279 x 358mm. Fits all BusyScreen® models

Code **G4158**



## Hook over shelf

Fits all BusyScreen® models except the Connect system

Size W 700mm  
 D 254mm  
 Code **RMA/6**



Size W 800mm  
 D 254mm  
 Code **RMA/5**



Size W 900mm  
 D 254mm  
 Code **RMA/4**



## Hook over racks

Extra wide wire mesh document and folder racks with 45mm deep capacity

**1 pocket rack**  
 Capacity 1 x 310mm wide pockets  
 Size H 248mm  
 W 337mm  
 D 102mm  
 Code **G6455BL**



**3 pocket rack**  
 Capacity 3 x 310mm wide pockets  
 Size H 457mm  
 W 337mm  
 D 102mm  
 Code **G6452BL**



## Hook over coat hook

Box of 6. Fits all BusyScreen® models

Code **G4224BL**



# BusyScreen® Partitions - Carnival



## BusyScreen® Carnival floor screen system

- Range of 11 modern textured fabrics
- Attractive silver coloured trim
- 32mm thick partition screens
- Flexible linking strip for joining screens together

Contemporary designed screens with a modern textured fabric that contrasts beautifully with the attractive silver coloured trim. These screens have a pinnable 32mm thick sturdy frame construction that provides an excellent acoustic shadow. Supplied with a flexible 'H' linking strip for joining up to 4 screens, adjustable button feet and specially designed stabilising feet that fit securely into the base of the screen to prevent twisting. Optional castor feet are available in lieu of stabilising feet - see page 167.

### TO ORDER:

Please state the product code followed by the textured cloth colour code required

### EXAMPLE:

1200 x 800mm in magenta cloth = **BC1280/MG**



Height 1200mm  
Width  
800mm **BC1280**  
1000mm **BC1210**  
1200mm **BC1212**  
1600mm **BC1216**



Height 1600mm  
Width  
800mm **BC1680**  
1000mm **BC1610**  
1200mm **BC1612**  
1600mm **BC1616**

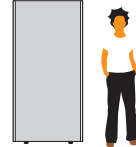

Height 1800mm  
Width  
800mm **BC1880**  
1000mm **BC1810**  
1200mm **BC1812**  
1600mm **BC1816**

### Carnival textured cloth colours - see page 173

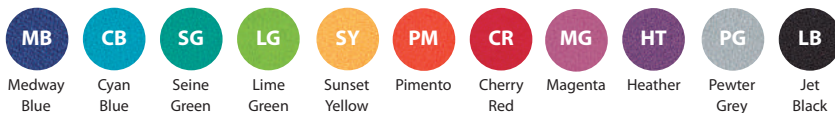

Silver coloured trim



Flexible linking strip

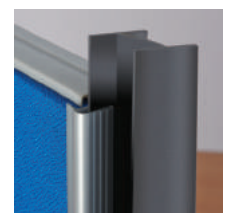



## BusyScreen® Carnival desktop screen system

- Contemporary curved top
- Range of 11 modern textured fabrics
- Attractive silver coloured trim
- 32mm thick partition screens

Desk mounted screens are available with aesthetically pleasing curved top and textured fabric that contrasts beautifully with the attractive silver coloured trim. These screens have a pinnable 32mm thick sturdy frame construction that provides an excellent acoustic shadow. All desktop screens require either a pair of clamps or screw in brackets depending on the depth of the table.

**TO ORDER:**  
Please state the product code followed by the textured cloth colour code required  
EXAMPLE:  
1800mm in medway blue cloth = **BC4518/MB**  
Then order separately a pair of clamps or brackets as required for each panel.



Height 400-500mm

Width

- 800mm **BC4580**
- 1000mm **BC4510**
- 1200mm **BC4512**
- 1400mm **BC4514**
- 1600mm **BC4516**
- 1800mm **BC4518**

### Pair of clamps

Fits desks between 12-30mm thick.

Code **BS00223**

### Pair of brackets

Fits desks over 30mm thick.

Code **BS71445**



Carnival textured cloth colours - see page 173

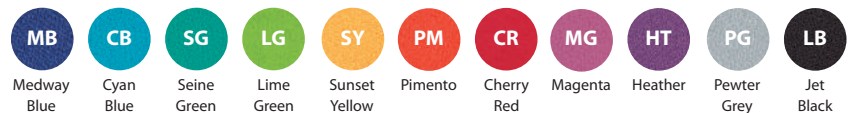

# BusyScreen® Partitions - Connect



## BusyScreen® Connect floor screen system

- High end traditional partitioning screen system
- 45mm thick panels trimmed in coated aluminium
- Rigid and Flexible linking strips with each panel
- 11 woven cloth options

High end traditional partitioning screen system provides excellent acoustic properties. Constructed with pinnable 45mm thick panels, powder coated dark grey aluminium side trims and foam backed woven cloth fabric. Supplied with adjustable button feet and a pair of stabilising feet that fit neatly within the aluminium side extrusion. Supplied with 2 types of 'H' linking strips, Rigid for joining 2 screens in a straight line and Flexible for joining at an angle.

**TO ORDER:**  
Please state the product code followed by the woven cloth colour code required  
**EXAMPLE:**  
1600 x 1200mm in black cloth = **BD1612/BL**



**Height 1200mm**  
Width  
800mm **BD1280**  
1000mm **BD1210**  
1200mm **BD1212**  
1600mm **BD1216**



**Height 1600mm**  
Width  
800mm **BD1680**  
1000mm **BD1610**  
1200mm **BD1612**  
1600mm\* **BD1616**

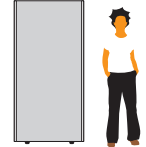

**Height 1800mm**  
Width  
800mm **BD1880**  
1000mm **BD1810**  
1200mm **BC1812**  
1600mm\* **BD1816**

\* Foam backed cloth on all models except these



Woven cloth colours - see page 173



Dark Blue Royal Blue Dolphin Tummel Red Meadow Ivy Black Merrick Iona Glass

Flexible linking strip



Rigid linking strip

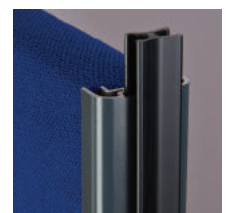



## BusyScreen® Connect desktop screen system

- High end traditional desk screens
- 45mm thick panels trimmed in coated aluminium
- Straight or Wave topped options
- 11 woven cloth options

This high end traditional desk top partitioning system provides excellent acoustic properties. 45mm thick panels with powder coated aluminium side trims in dark grey combine with a range of 11 foam backed woven cloth fabric colours. All 6 sizes of straight or wave desktop screens require a pair of clamps or screw in brackets depending on depth of table.

**TO ORDER:**  
Please state the product code followed by the woven cloth colour code required  
**EXAMPLE:**  
400-600 x 1800mm in Dolphin cloth = **BC6418/DO**  
Then order separately a pair of clamps or brackets as required for each panel.

### Straight Top Desk Partitions



Height 400mm

Width

800mm	<b>BD4080</b>
1000mm	<b>BD4010</b>
1200mm	<b>BD4012</b>
1400mm	<b>BD4014</b>
1600mm	<b>BD4016</b>
1800mm	<b>BD4018</b>

### Wave Desk Partitions

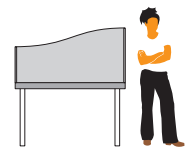

Height 400-600mm

Width

800mm	<b>BD6480</b>
1000mm	<b>BD6410</b>
1200mm	<b>BD6412</b>
1400mm	<b>BD6414</b>
1600mm	<b>BD6416</b>
1800mm	<b>BD6418</b>

### Pair of clamps

Fits desks between 12-30mm thick.

Code **BS00223**



### Pair of brackets

Fits desks over 30mm thick.

Code **BS71445**



Woven cloth colours - see page173



# BusyScreen® Partitions - Colour Swatches

## BusyScreen® loop nylon fabrics

Foam backed brushed nylon fabric is popular for use within educational establishments as it also accepts Velcro® for displaying children's artwork or posters. Complies to the flammability requirements of BS 5867-2 : Type B : 2008. Available in 18 popular colour options.

## BusyScreen® woven fabrics

Bradbury® screen 66 is a traditional hardwearing woven fabric made from 100% polypropylene in the UK. This fabric conforms to surface spread of flame test BS476 part 7 class 1, BS EN 1021-1:2006 and is also light fast to meet 6+ ISO 105-B02:1999. Abrasion is tested in accordance with bs en ISO 12947-2:1999 as modified by annex F of BS 2543:2004 to 40,000 rubs martindale. Available in 11 colours - full range to special order.

## BusyScreen® textured fabrics

Bradbury® Galaxy Screen is a modern contemporary textured fabric that has a with a tighter weave and is made from 100% Polyester. Fire retardancy conforms with vertical surface test BS 476 Part 7 Class 1 and BS EN 1021 – 1&2:2006 BS5852. This product is light fast to 6+ ISO 105-B02:1999. Abrasion is tested in accordance with BS EN ISO 5690:1991 as modified by Annex F of BS 2543:2004 to 50,000 rubs Martindale. Available in 11 vibrant colours - full range to special order.

## BusyScreen® loop nylon fabrics **Curve** p162 - 163 : **Classic** p164 - 166



**IN**

Ink Navy

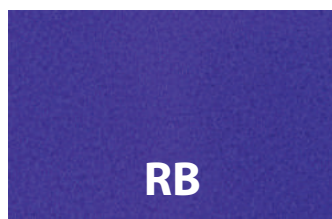

**RB**

Royal Blue



**BB**

Blueberry

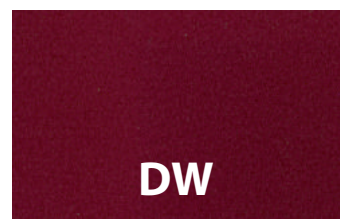

**DW**

Dark Wine



**SC**

Scarlet



**YL**

Yellow

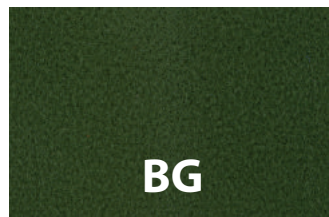

**BG**

Bottle Green



**EG**

Emerald Green



**QU**

Quince

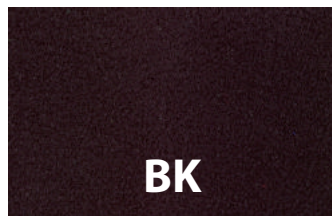

**BK**

Black



**GM**

Gunmetal



**LG**

Light Grey



**PU**

Purple



**MG**

Magenta



**LC**

Lilac



**OR**

Orange



**CY**

Cyan

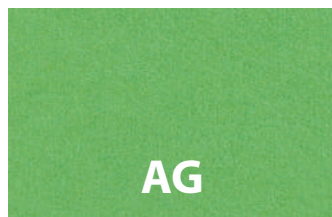

**AG**



Apple



BusyScreen® woven fabrics **Curve** p162 - 163 : **Classic** p164 - 166 : **Connect** p170 - 171

 <b>DB</b> Dark Blue S123	 <b>RY</b> Royal Blue S126	 <b>DO</b> Dolphin S100	 <b>TM</b> Tummel S118
 <b>RD</b> Red S120	 <b>IO</b> Iona S124	 <b>MW</b> Meadow S108	 <b>IV</b> Ivy S107
 <b>BL</b> Black S125	 <b>MK</b> Merrick S112	 <b>GS</b> Glass S111	 Full range to special order

BusyScreen® textured fabrics **Carnival** p168 - 169

 <b>MB</b> Medway Blue G657	 <b>CB</b> Cyan Blue G679	 <b>SG</b> Seine Green G658	 <b>LG</b> Lime Green G682
 <b>SY</b> Sunset Yellow G640	 <b>PM</b> Pimento G671	 <b>CR</b> Cherry Red G644	 <b>MG</b> Magenta G683
 <b>HT</b> Heather G611	 <b>PG</b> Pewter Grey G668	 <b>JB</b> Jet Black G620	 Full range to special order



## Rope and pole barrier system

### Traditional rope and pole system

Poles are 975mm high and available in a choice of chrome or matte black. Plush 2m long rope in either black, blue or red. Ropes attach securely to the circular fixings below the attractive spherical finials. Heavy base for stability.

Pole		Rope	
Size	H	Size	L
Black	975mm	Black rope	2000mm
Chrome		Blue rope	
		Red rope	
		<b>ROP100</b>	<b>ROP300</b>
		<b>ROP200</b>	<b>ROP301</b>
			<b>ROP302</b>

### Rope colours

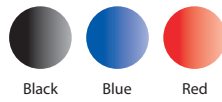

Chrome pole



Black pole



## Retractable barrier system

### Contemporary retractable tape system

Posts are 977mm high and available in a choice of chrome or matte black. 2m long tape in either black, blue or red. Each tape unfurls from its integral cassette to clip securely to the adjacent post. Heavy base for stability.

### Tape colours

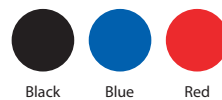

Chrome post



### Chrome post

Post height	977mm
Tape length	2000mm
Black tape	<b>RET103</b>
Blue tape	<b>RET104</b>
Red tape	<b>RET105</b>

Black post



### Black post

Post height	977mm
Tape length	2000mm
Black tape	<b>RET100</b>
Blue tape	<b>RET101</b>
Red tape	<b>RET102</b>



# Meeting Room Furniture

- 176 - 180 Tables
- 181 - 183 Chairs
- 184 - 185 Lecterns
- 186 - 187 Glazed Display Cases
- 188 Uplighter
- 188 - 189 Clocks
- 190 - 191 Coat Stands
- 192 Coat Hooks



## Meeting Room Furniture - Tables



### Round meeting room tables

A simple, yet practical and sturdy design

New circular table additions to the popular range of Meeting Room Tables. These tables have a 25mm beech laminate top and 60mm diameter, height adjustable legs which unscrew for storage or transportation.

#### Small round table

Size H 735mm  
W 800mm  
Weight 12kg  
Code **214604**

#### Large round table

Size H 735mm  
W 1000mm  
Weight 18kg  
Code **214605**



214600



## Meeting room tables

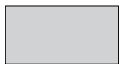

### A simple design, yet practical and sturdy

These tables have a 25mm beech laminate top and 60mm diameter, height adjustable legs which unscrew for storage or transportation. Joining links are available for more permanent requirements.

#### Rectangular table

Size H 735mm  
W 1360mm  
D 680mm  
Weight 21kg  
Code **214600**

#### Trapezoid table

Size H 735mm  
W 1360mm  
D 590mm  
Weight 19kg  
Code **214601**

#### Semi-circular table

Size H 735mm  
W 1360mm  
D 680mm  
Weight 19kg  
Code **214602**

#### Fixing kit

To join any 2 tables  
Pair **214603**

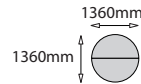
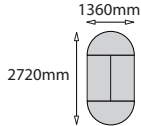
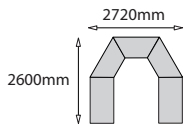

# Meeting Room Furniture - Tables



## EasyFold® meeting room tables

Rugged folding tables for decades of use

A range of modular folding tables that enable you to create alternative layouts to match your requirements. Heavy duty folding legs with adjustable feet provide a stable base when erected, the table is only 75mm deep when folded flat. Available in beech effect finish with tough ABS edging, complimented with black under frame and legs. Fixing links are available to join tables for more permanent configurations.



### Rectangular table

Size H 735mm  
W 1350mm  
D 680mm  
Weight 24kg  
Code **215600**



### Trapezoid table

Size H 735mm  
W 1360mm  
D 590mm  
Weight 23kg  
Code **215602**

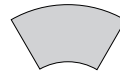

### 60° segment table

Size H 735mm  
W 600mm  
D 680mm  
Weight 23kg  
Code **215604**



### Semi-circular table

Size H 735mm  
W 1360mm  
D 680mm  
Weight 23kg  
Code **207122**



### Quadrant link

Size H 735mm  
W 680mm  
D 680mm  
Weight 10kg  
Code **215609**

### Fixing plates

To join any 2 tables  
Pair **207160NB**

### Table transporter

takes any 6 Easyfold tables  
Size H 1200mm  
W 1500mm  
D 500mm  
Code **207150**

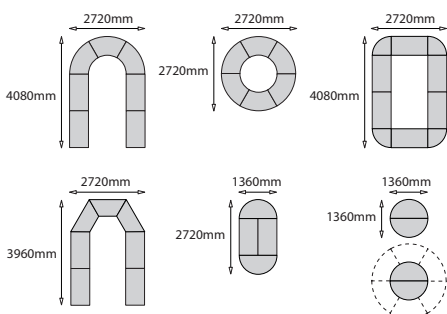

## Tilt Top meeting room tables

Stylish range of tables ideal for meeting room, conference room, board room and break out areas

Easily mobile thanks to the 65mm castors, 2 locking. Chromium plated metal frame offers stability when in situ creating a professional table layout. 2 table shapes available allowing you to create various configurations, see the suggestions below. A 90° quadrant connector is available, ideal to create larger table layouts. Durable 25mm table tops available in 3 modern colour finishes including Wenge, White and Beech. Table connectors can be purchased separately to secure table layouts together for a more permanent setup. 2 per join of full size tables - 1 per join of quadrant corner.

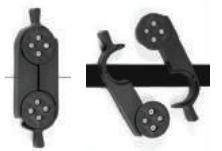

### Tabletop finishes

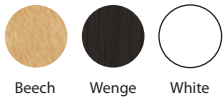

Beech Wenge White

### Shaped table

Size H 746mm  
W 1600mm  
D 800mm  
Beech **84101**  
Wenge **84104**  
White **84107**

### Rectangular table

Size H 746mm  
W 1600mm  
D 800mm  
Beech **84102**  
Wenge **84105**  
White **84108**

### Quadrant corner

Size H 25mm  
W 800mm  
D 800mm  
Beech **84103**  
Wenge **84106**  
White **84109**

Table connector  
Locks 2 tables together  
2 recommended per join  
Each **84110**

Kit A - includes 2 connectors

Size H 746mm  
W 1600mm  
D 1600mm

Beech **84201**  
Wenge **84205**  
White **84209**



Kit B - includes 4 connectors

Size H 746mm  
W 2400mm  
D 1600mm

Beech **84202**  
Wenge **84206**  
White **84210**



Kit C - includes 6 connectors

Size H 746mm  
W 3200mm  
D 1600mm

Beech **84203**  
Wenge **84207**  
White **84211**



Kit D - includes 8 connectors

Size H 746mm  
W 3200mm  
D 3200mm

Beech **84204**  
Wenge **84208**  
White **84212**  
Beech/Wenge as illustrated **84213**



# Meeting Room Furniture - Tables



## Trestle tables

Offering a truly flexible solution to temporary tabling

Easy to erect and easy to store using the simple folding leg mechanism with locking collar. Very stable and strong powder coated metal frame. Durable 18mm beech melamine table top. Tables can be stacked 10 high for easy storage. Available in 3 sizes, all 725mm in height.

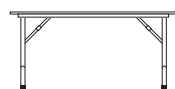

Size H 725mm  
W 1600mm  
D 800mm  
Weight 25.2kg  
Code **94100**



Size H 725mm  
W 1800mm  
D 800mm  
Weight 26.8kg  
Code **94101**



Size H 725mm  
W 2000mm  
D 800mm  
Weight 30.4kg  
Code **94102**

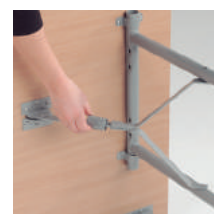
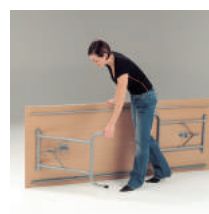

## 'Lena' cantilever stacking conference chairs

Our premium conference chair with cantilever frame which offers exceptional comfort

The stylish arms with a beech finish gently slope giving ultimate support and a contemporary look. Soft upholstered seat and backrest is available in a choice of blue, red or black woven cloth. Solid chromium plated metal frame offers years of trouble free use. Stackable - recommended 3 maximum. Sold in sets of 2 chairs.

Size H 830mm  
W 540mm  
D 555mm

Sets of 2  
Red **94030**  
Blue **94031**  
Black **94032**

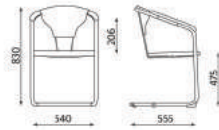

### Chair fabrics

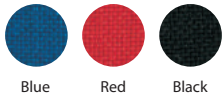

Blue Red Black



94017/4/CL



## 'Jane' meeting room chairs

The classic conference chair offering comfort and value

Stacking conference chair available in three woven cloth colours with black or chrome framework. Offered with or without arms with a range of accessories such as writing tablets and chair connectors. Chair stacks 10 high for optimum storage. Sold in sets of 4 chairs.

### TO ORDER:

Please state the product code followed by the colour code of the cloth required.

EXAMPLE: Chrome frame without arms in Blue cloth = **94017/4/CL**

### Chair fabrics



Blue Burgundy Black



### Black frame

Size H 820mm  
W 545mm  
D 425mm

### Sets of 4

Without arms **94015/4**  
With arms **94016/4**

### Chrome frame

Size H 820mm  
W 545mm  
D 425mm

### Sets of 4

Without arms **94017/4**  
With arms **94018/4**

### Accessories

#### Writing tablet

Size W 375mm  
D 275mm  
Black - Right **94028/R**  
Black - Left **94028/L**  
Beech - Right **94028/BR**  
Beech - Left **94028/BL**

#### Chair connectors

Black **94021**  
Chrome **94022**

# Meeting Room Furniture - Chairs



## 'Roma' meeting room chairs

This sled based chair has a soft upholstered seat and backrest

Resilient chromium plated metal frame. Sold in sets of 4. This chair will stack up to 10 high unsupported but has the added advantage of a trolley accessory which will accept up to 25 chairs, ideal for transporting Roma chairs to areas that are rearranged regularly.

### Chair fabrics

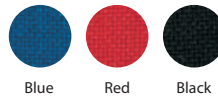

Blue Red Black

### Chair

Size H 845mm  
W 515mm  
D 550mm

### Sets of 4

Red **94036**  
Blue **94037**  
Black **94038**

### Transport trolley

Size H 820mm  
W 545mm  
D 425mm

Takes 25 chairs **94039**

### Chair connectors

Pair **940RL**

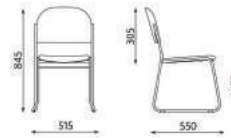

## 'Lola' reception seating

Low slung comfortable chairs, ideal for reception and waiting areas

Solid wood frame, available with or without arms. Model without arms will stack up to 4 pieces. Ideal to complete your waiting area, creating a comfortable environment. Choice of blue, red or black robust woven cloth.



### Chair without arms

Size H 760mm  
W 630mm  
D 545mm

Red **94041**  
Blue **94042**  
Black **94043**

### Chair with arms

Size H 760mm  
W 630mm  
D 545mm

Red **94044**  
Blue **94045**  
Black **94046**

### Chair fabrics

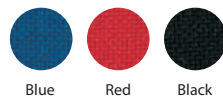

Blue Red Black





## 'Katie' break out chairs

Fashionable zingy colours and comfortable yet durable polypropylene chair

Available in glossy lime green, red or white. High quality chromium plated metal frame. Stackable up to 6 high for useful storage. Sold in sets of 4 chairs.



### Chair

Size H 830mm  
W 512mm  
D 475mm

### Sets of 4

Red **94033**  
Lime **94034**  
White **94035**

### Chair colours

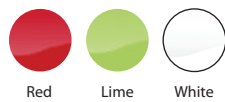

## 'Annie' break out chair

Traditional style with a sturdy plywood shell

Solid metal chromium plated frame. Inbuilt handle to allow people to move the chairs easily, typical of break out areas. Stackable up to 4 chairs. Sold in sets of 4 chairs.

### Chair

Size H 820mm  
W 500mm  
D 460mm

### Sets of 4

Beech **94040**



# Meeting Room Furniture - Lecterns



## Standard folding lectern

Impressive lectern that folds flat for easy storage

Finished in beech effect with tough ABS edging. Both lecterns are only 190mm deep when closed. Supplied assembled. Useful Transporter is available to assist in storing or moving the lectern from room to room.

### Floor Standing

Floor standing lectern with large sloping shelf and accessory shelf. The shelves and two hinged side panels fold flat to aid moving and storage. Sloping shelf has book/paper ledge to aid the presenter.

### Tabletop

Tabletop lectern with large sloping shelf and paper ledge. The shelf and 2 hinged side panels fold flat to aid portability and storage.

### Floor Standing

Open Size H 1240mm  
W 620mm  
D 460mm  
Weight 29kg  
Floor **215517**

### Tabletop

Open Size H 500mm  
W 620mm  
D 460mm  
Weight 14kg  
Desktop **215513**

## Acrylic top lectern

### Lightweight stylish lectern

A simple lectern with an aluminium post and acrylic top which features a 20mm document retaining lip. Requires simple self assembly.

### Note:

Lightweight design, not designed to carry heavy weight or be leaned on



Size H 1110mm  
Sloping top W 470mm  
D 320mm  
Code **LD3090**



### Tabletop Lectern



### Transporter

Code **GPT90**



## Coloured or Beech Panel Front Lecterns

New contemporary colour finishes for our best-selling mobile panel front lectern

The lecterns feature an angled upper shelf with a steel book rest and a lower accessory shelf. 4 castors, 2 of which are locking. Simple self-assembly. Made in the UK.

### Beech Lectern

Popular mobile lectern finished in beech laminate with a grey steel framework.

### Coloured Lecterns

Available in a range of 7 colour options with a dark grey steel framework. A colourful edition to the popular beech version.

### TO ORDER:

Please state the product code followed by the colour code of the board required.

EXAMPLE: Lectern in Red = **214421/RD**

Size H 1200mm  
W 600mm  
D 450mm  
Beech **215521**  
Coloured **214421**



Beech Lectern 215521



Coloured Lectern 214421/RD



214421/RD

### Coloured Lectern Range



Black

Blue

Red

White

Lime

Purple

Orange

# Meeting Room Furniture - Glazed Display Cases



## Shield® glazed wall display cases

Display 3D objects in style with the Shield® wall mounted display cases

A stylish range of display cases manufactured to the highest standard. Heavy duty yet contemporary aluminium framing, and toughened safety glass are used to create this range of wall showcases. These wall mounted cabinets are available in a choice of two popular sizes. All units are lockable and supplied with glass shelving as illustrated. Available in satin anodised aluminium or in a choice of four bright powder coat colours. Supplied ready assembled.

Illuminated versions of the Shield glazed display cases bring your display to life. Spotlights are clipped into a 12 volt track, enabling the illumination to be positioned exactly where you need it. The lights are simple to remove when not required or when sensitive displays are being housed.

### TO ORDER:

Please state the product code followed by the frame colour code required  
 EXAMPLE: Wall cabinet unit 900 x 1200 x 200mm with white frame = **XS1000/WH**

### Frame colours



Aluminium Blue Green Red White



### Wall cabinet

Size H 900mm  
 W 1200mm  
 D 200mm

Aluminium **GS1000**  
 Coloured **XS1000**

### Illuminated

Aluminium **GS1000L**  
 Coloured **XS1000L**

### Wall cabinet

Size H 1000mm  
 W 1000mm  
 D 200mm

Aluminium **GS1001**  
 Coloured **XS1001**

### Illuminated

Aluminium **GS1001L**  
 Coloured **XS1001L**

Illuminated



## Shield® glazed tower display cases

Display 3D objects in style with the Shield® mobile display cases

A stylish range of display cases manufactured to the highest standard. Heavy duty yet contemporary aluminium framing and toughened safety glass are used to create this range of freestanding showcases. Six tower units are available in a range of sizes, two with locking cupboards to the base. All units are lockable and supplied with glass shelving as illustrated. Available in satin anodised aluminium or in a choice of four bright powder coat colours. Supplied ready assembled with castors, button feet are available as a no cost alternative – please specify when ordering.

Illuminated versions of the Shield® glazed display cases bring your display to life. Spotlights are clipped into a 12 volt track, enabling the illumination to be positioned exactly where you need it. The lights are simple to remove when not required or when sensitive displays are being housed.

### TO ORDER:

Please state the product code followed by the frame colour code required

EXAMPLE: Coloured tower unit 2000 x 600 x 600mm with red frame = **XS1002/RD**

GS1007L



XS1002/RD



XS1005L/BL



### Frame colours



#### Tower unit

Size H 2000mm  
W 600mm  
D 600mm

Aluminium **GS1002**  
Coloured **XS1002**



#### Tower unit

Size H 2000mm  
W 500mm  
D 500mm

Aluminium **GS1003**  
Coloured **XS1003**



#### Wide tower

Size H 2000mm  
W 1200mm  
D 600mm

Aluminium **GS1006**  
Coloured **XS1006**



#### Wide tower

Size H 2000mm  
W 1000mm  
D 500mm

Aluminium **GS1007**  
Coloured **XS1007**

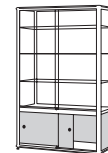

#### Tower with cupboard

Size H 2000mm  
W 1200mm  
D 600mm

Aluminium **GS1004**  
Coloured **XS1004**

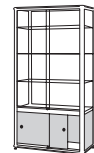

#### Tower with cupboard

Size H 2000mm  
W 1000mm  
D 500mm

Aluminium **GS1005**  
Coloured **XS1005**

#### Illuminated

Aluminium **GS1002L**  
Coloured **XS1002L**

#### Illuminated

Aluminium **GS1003L**  
Coloured **XS1003L**

#### Illuminated

Aluminium **GS1006L**  
Coloured **XS1006L**

#### Illuminated

Aluminium **GS1007L**  
Coloured **XS1007L**

#### Illuminated

Aluminium **GS1004L**  
Coloured **XS1004L**

#### Illuminated

Aluminium **GS1005L**  
Coloured **XS1005L**

# Meeting Room Furniture - Clocks and Uplighter



## Big clock

Ultra clear large diameter analogue wall clock

380mm diameter clock with large black numbers for extra clarity. ABS case finished in Satin Silver. Takes one AA 1.5v Battery (not supplied)

### Big clock

Size W 380mm  
D 50mm  
Code **VA111**



## Giant clock

A large analogue clock with 600mm diameter dial

Large black numbers for extra clarity. ABS case finished in silver. Takes an AA battery. 3 year warranty

### Giant clock

Size W 600mm  
D 50mm  
Code **VA115**



## Uplighter

Elegant floor standing uplighter

Provides controllable background lighting to a maximum of 200w with foot dimmer to adjust brightness. Matte black finish with subtle green decal

Size H 1800mm  
Head diameter 320mm  
Base diameter 290mm  
Code **VA105**



## Coloured clocks

### Inexpensive range of analogue wall clocks

Clear 300mm diameter white faced clock with black numbering available with a range of coloured bezels. Choose from grey, black, green, purple, red or white. Takes one AA 1.5v Battery (not supplied). 3 year warranty.

#### Coloured clock

Size W 300mm  
D 55mm

Grey **VA107**  
Black **VA108**  
Green **VA114**  
Purple **VA109**  
Red **VA110**  
White **VA106**



Grey

Black

Green

Purple

Red

White



## World clock

Set of 3 clocks to show different time zones

Keep track of time at your branches, associates or customers. Easy place name change and adjustment. 3 year warranty. Takes AA batteries.

## LED clock

Illuminated clock with digital display

A modern, eye-catching clock with a circle of LEDs that move with the time. 50mm high numerals for clarity. Mains operated.

#### World clock

Size H 330mm  
W 900mm  
D 30mm  
Code **VA117**

#### LED clock

Size W 300mm  
D 40mm  
Code **VA116**



# Meeting Room Furniture - Coat Stands

## Silver coat stand

Compact coat and umbrella stands

This popular coat stand also houses up to 6 umbrellas with a built in drip tray. 38cm heavy cast steel base for stability. 8 wooden coat hangers.

### Silver Coat Stand

Size H 1750mm  
W 380mm  
D 380mm

Code **VA101**



## Handy coat stands

Compact coat and umbrella stands

These popular coat stands also house up to 6 umbrellas with a built in drip tray. 38cm heavy cast steel base for stability. Choice of Silver with 5 wooden hangers or all black frame with 5 matching hangers.

### Handy Stand - Silver

Size H 1870mm  
W 380mm  
D 380mm

Code **VA100**



### Handy Stand - Black

Size H 1870mm  
W 380mm  
D 380mm

Code **VA118**



## Classic coat stand

A budget coat and umbrella stand

A budget priced coat stand featuring a classic design in matte black that also accepts up to 4 umbrellas. All black steel frame with 5 hat and coat hooks.

### Classic Coat Stand

Size H 1750mm  
W 500mm  
D 500mm

Code **VA119**





## Deluxe secure coat rail

All black coat rack with secure coat hangers

This attractive unit is supplied with 17 x 2 piece security coat hangers to prevent loss. Also takes umbrellas and bags. Locking castors. Easy self assembly.

Size H 1600mm  
W 1220mm  
D 520mm  
Code **VA120**

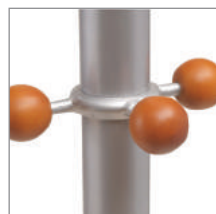

## Silver coat rail

Practical coat, bag and umbrella storage

Store coats, bags and accessories on this free standing unit. Finished in silver powder coated steel frame with wooden features. High capacity hanging rail includes 6 matching hangers. Supplied with four castors to aid mobility. Easy self assembly.

**Additional steel hangers**

Matching coat hangers finished in metallic grey steel with light wood fittings. Available in a pack of 6.

**Stand**

Size H 1800mm  
W 1140mm  
D 550mm

Code **VA103**

**Hangers**

Pack of 6

**VA104**

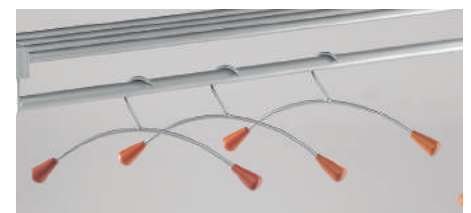

# Meeting Room Furniture - Coat Hooks



## Wood coat hooks

### Flip out wood coat hooks

Attractive design, finished in cherry with a choice of 3 or 5 brushed nickel hooks. The flip down hooks are designed to store flush with the contoured wooden unit when not in use. Concealed fixings supplied.



#### 3 hook

Size H 76mm  
W 305mm  
D 70mm

Code **G4242CY**

#### 5 hook

Size H 76mm  
W 508mm  
D 70mm

Code **G4243CY**

## Mesh coat hooks

### Simple steel mesh design

Large rounded hooks to protect your clothing. Available in a choice of 2, 3 or 5 hook versions. Contemporary black coated steel and mesh with concealed keyhole fixings supplied.



#### Mesh 2 hook

Size H 140mm  
W 216mm  
D 76mm

Code **G6401BL**

#### Mesh 3 hook

Size H 140mm  
W 375mm  
D 76mm

Code **G6402BL**

#### Mesh 5 hook

Size H 140mm  
W 680mm  
D 76mm

Code **G6403BL**

## Brushed steel coat hooks

### Beautifully styled brushed steel and aluminium finish

These sturdy aluminium curved coat hooks are fitted to a brushed steel base which arcs out from the wall to conceal the fixings which are supplied. Choice of 2, 3 or 4 hook versions.



#### Steel 2 hook

Size H 127mm  
W 178mm  
D 114mm

Code **G4203SL**

#### Steel 3 hook

Size H 127mm  
W 273mm  
D 114mm

Code **G4204SL**

#### Steel 4 hook

Size H 127mm  
W 362mm  
D 114mm

Code **G4205SL**



# Audio Visual Furniture

- 194 Projector Stands
- 195 - 198 Locking Projector Cabinets
- 198 - 201 Locking TV Cabinets
- 202 Mobile TV Stands



# Audio Visual Furniture - Projector Stands

## Secure MM projector trolley

Twin column trolley for extra stability and capacity

Mobile multi-media trolley with two independently height adjustable platforms that can both rotate and angle. Robust steel trolley mounted on 4 castors, two of which are lockable.

### Deluxe MM Trolley

Additional 300 x 350mm shelf and cable management cover.

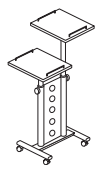

#### Mobile MM trolley

Min Height 800mm  
Max Height 1250mm  
Each Platform W 350mm  
D 400mm  
Code **215715**

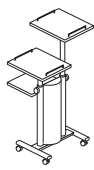

#### Deluxe MM trolley

Min Height 800mm  
Max Height 1250mm  
Each Platform W 350mm  
D 400mm  
Code **215715DL**

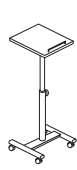

#### 125 trolley

Min Height 700mm  
Max Height 1100mm  
Platform W 380mm  
D 420mm  
Weight 12kg  
Code **215721**

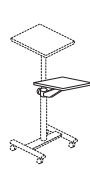

#### Side platform

Size W 395mm  
D 300mm  
Code **215723**



## Folding projector stand

Lightweight folding projector stand

This economical projector stand folds flat for easy carrying and compact storage. The large upper platform has tilt adjustment, the second lower platform folds flat when not in use. Tubular steel frame with adjustable foot to assist stability on uneven floors.



#### Folding stand

Height 1150mm  
Top Platform W 600mm  
D 400mm  
Bottom Platform W 280mm  
D 450mm  
Weight 10kg  
Code **202001**



# Locking Projector Cabinets - **Audio Visual Furniture**



## MM80 multi-media projector cabinets

### Economical multi-media cabinets

Low cost solution to housing your multi-media projector and associated equipment. Cable accessory port on top and side. 3 shelves - 1 sliding, 100mm wheels - 2 locking. Locking door with 2 keys. Supplied ready assembled.

Size H 930mm  
W 540mm  
D 600mm  
Beech **MM80**  
Red Door **MM80RD**  
Blue Door **MM80BL**

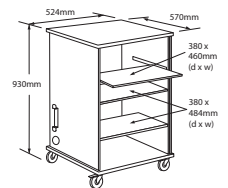

MM80RD



MM80BL



# Audio Visual Furniture - Locking Projector Cabinets

MM90



4 shelves - 3 sliding



**NEW Rack Mount Cabinet for MM90 and MM100**  
Now available with a rack mount in place of shelving. Please ask for further details.

## Secure MM90 multi-media projector cabinets

### Best selling premier mobile multi-media cabinets

Market leading cabinet with extra security features. Designed to house all your multi-media projection equipment. Three point door lock and locking rear access panel. 3 slide out and 1 fixed shelf. Additional cable ports and cable tidy. Accessory storage tray to inside of door. 100mm soft tyred wheels, 2 locking. Supplied ready assembled.

Size H 930mm  
W 524mm  
D 570mm  
Beech **MM90**  
Red Door **MM90RD**  
Blue Door **MM90BL**

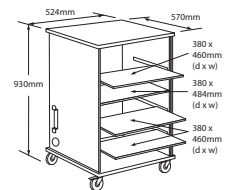

### Lockable doors



### Lockable rear access for cabling



MM90RD



MM90BL



## MM100 coloured mobile multi-media cabinets

The popular MM90 projector cabinet has now been developed in a range of 7 striking colours

Designed to accommodate your multi-media projector, DVD player, amplifier, laptop, speakers and all your accessories. Rear lockable access door provides easy access to cabling and connections for your AV equipment. 4 shelves, 3 of which slide. 3 cable access points. Generous 100mm wheels (2 with brakes). Cable tidy and accessory tray inside door. Supplied ready assembled. The MM100 also features soft edged platforms to reduce the risk to decor while manoeuvring the cabinet from room to room.

### TO ORDER:

Please state the product code followed by the colour code of the cabinet required.

EXAMPLE: MM100 cabinet in blue = **MM100/BL**

Size H 930mm  
W 524mm  
D 570mm  
Code **MM100**



MM100/BL



Black



Blue



Red



White



Lime



Purple



Orange

### 3 Sliding Shelves



### Matching Keys



### Cable Tidy



### Cable Access Points



MM100/OR



# Audio Visual Furniture - Locking Projector and TV Cabinets



## Mitre® audio visual furniture

Mitre® products feature a contemporary curved smoked glass front door and a rear access plate with matching keys

Neutral light grey cabinet designs are complimented by a choice of three attractive coloured top and base platforms. Heavy duty steel lockable access plate to rear measures 450 x 160mm (h x w) and is vented to assist with temperature control. Locks for front and rear access are keyed alike. 3 height adjustable shelves, sliding top shelf and a practical sliding draw at base. Durable 100mm Tente® twin wheeled, precision ball bearing castors, 2 locking. Maximum spread load capacity recommended at 150kgs. Optional 19" rack mount accessory available with 23 hole pitch positions.

### Conference Cabinet

The cabinet is supported by a stylish yet superior strength steel LCD stand with integral base for maximum stability. VESA compatible bracket will secure LCD screens up to 65" and allows for full height adjustments in increments of 40mm up to a maximum of 800mm above the top platform. The bracket tilts up to a 15° angle. Full length vented rear access cable management cover. Optional height adjustable video conference shelf that can be secured above the LCD screen to convert this module in to a truly professional video conferencing tool.

### LCD mounting bracket

Robust steel bracket supports VESA hole configurations of 75 x 75mm, 100 x 100mm, 200 x 100mm, 200 x 200mm, 400 x 200mm and 400 x 400mm. 400mm VESA pattern is achieved by securing the additional attachment plates that are provided as standard and may be required with larger sets. Recommended maximum set weight of 45Kg.



Mitre® Multi-media  
Standard cabinet

Cabinet	H 953mm	Graphite	<b>VIP90G</b>
	W 700mm	Aqua	<b>VIP90B</b>
	D 550mm	Ruby	<b>VIP90R</b>



Mitre® Presenter

With TV stabilising VESA bracket designed to take sets up to 50" when used with manufacturer's stand

Cabinet	H 953mm	Graphite	<b>VIP91G</b>
	W 700mm	Aqua	<b>VIP91B</b>
	D 550mm	Ruby	<b>VIP91R</b>

Overall height to 1340mm  
centre of support bracket



Mitre® Presenter XL

Extra wide with TV stabilising VESA bracket to take sets up to 65" when used with manufacturers stand

Cabinet	H 953mm	Graphite	<b>VIP92G</b>
	W 950mm	Aqua	<b>VIP92B</b>
	D 550mm	Ruby	<b>VIP92R</b>

Overall height to 1340mm  
centre of support bracket



# Locking TV Cabinets - Audio Visual Furniture

## 3 colour options



Graphite



Aqua



Ruby

## Features



VESA supports for TV units



Large configuration VESA bracket included

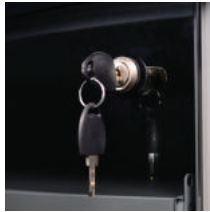

Locking IR compatible glass doors



Durable Tente® 100mm wheels



Infra-red compatible glass door



Rear easy access plate



Video conferencing camera shelf

Optional 19" rack

## Easy access - with cover plate removed



## Mitre® Conference

Premier cabinet with large monitor mounting column

Cabinet H 980mm  
W 755mm  
D 650mm

Graphite  
Aqua  
Ruby

**VIP93G**  
**VIP93B**  
**VIP93R**

Overall height to 1800mm  
centre of mounting bracket



## Optional 19" rack mount

to fit all units

Size L 400mm  
Code **VIP103**



## Video conferencing camera shelf

fits to Conference unit

Size W 280mm  
D 280mm  
Max. height 2160mm  
from floor to shelf  
Code **VIP102**



# Audio Visual Furniture - Locking TV Cabinets



## Secure 160 cabinets

### Fully enclosed locking cabinet

Secure cabinet that houses a television together with a shelf for associated equipment such as a Blu-ray player or satellite box. Lockable doors hinge open by 270° for maximum visibility. Beech cabinet with dark grey steel frame; easily manoeuvred on four 10cm diameter wheels. The locking cabinet is suitable for housing screens up to 32" in size. A height adjustable VESA plate is mounted to the rear of the cabinet to stabilise the flat screen TV. VESA compatible with 75 x 75mm, 100 x 100mm, 200 x 100mm or 200 x 200mm hole configurations.

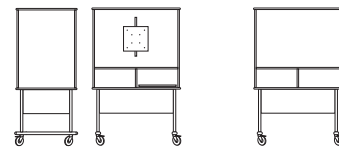
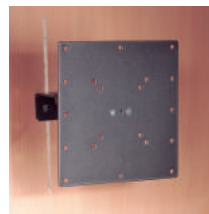

### 160 TV cabinet

Size H 1600mm  
W 1040mm  
D 680mm  
Code **215662**

### 160 general purpose cabinet

Size H 1600mm  
W 1040mm  
D 680mm  
Code **215652**

## Secure 240 cabinets

### Maximum storage and protection

A mobile cabinet that offers maximum storage for your TV equipment and accessories. Height adjustable shelves and computer compartment offers ample flexible storage. A height adjustable VESA plate is mounted to the rear of the cabinet to stabilise the flat screen TV. VESA compatible with 75 x 75mm, 100 x 100mm, 200 x 100mm or 200 x 200mm hole configurations. The locking cabinet is suitable for housing screens up to 32" in size.

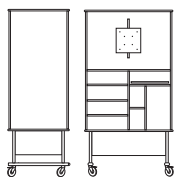

240 TV cabinet  
Size H 1900mm  
W 1040mm  
D 680mm  
Code **215666**

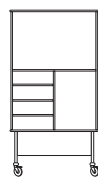

240 general purpose cabinet  
Size H 1900mm  
W 1040mm  
D 680mm  
Code **215656**



3 extra shelves  
Code **215744**

## Secure 110 cabinets

### Popular locking cabinet for larger TV sets

Mobile lockable cabinet that houses all your support AV, IT equipment and accessories. The television can sit atop the TV cabinet or mount directly to a substantial central column. VESA mount compatible with 75 x 75mm, 100 x 100mm, 200 x 100mm or 200 x 200mm hole configurations.

Three models are available all finished in beech with substantial steel under frame:

- 1 General purpose cabinet for secure equipment storage
- 2 AV cabinet with PC compartment and keyboard shelf
- 3 TV cabinet with VESA central mounting column to take a wide range of screen sizes

Optional universal mount for non-VESA or hole patterns over 200 x 200mm, can take sets up to 45kg. Maximum hole pitch for the universal bracket is 720 x 455mm (W x H).



110 general purpose cabinet

Size H 900mm  
W 1040mm  
D 680mm

Code **215650**



110 AV cabinet

Size H 900mm  
W 1040mm  
D 680mm

Code **215660**

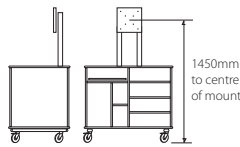

110 TV cabinet

Size H 1450mm  
W 1040mm  
D 680mm

Code **215668**



3 extra shelves

Code **215744**

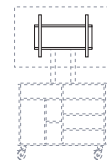

Universal bracket

Code **215684**

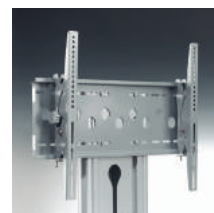

# Audio Visual Furniture - Mobile TV Stands



Rear cable tidy



Tilting VESA bracket



Removable back cover for cabling



## Secure mobile TV stand

Mount up to 50" TV sets

Modern and stylish stand for large flat screen TVs with unique features. Integral cable tidy as part of stand design, via removal back cover. Tilting VESA plate suitable for 75 x 75mm, 100 x 100mm, 200 x 100mm and 200 x 200mm mounting patterns. Optional universal mounting bracket for large or non VESA sets. Maximum hole pitch for the universal bracket is 720 x 455mm (W x H). Max load capacity is 45kg. Optional shelves quickly mount and demount to the stand. The locking cabinets fit to the stand from within therefore increasing security. A cabinet with a locking door that passes infrared signals is available. Supplied with 60mm heavy duty wheels (2 locking) and adjustable button feet.

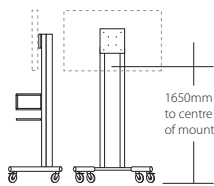

**Grey stand**  
 Size H 1650mm  
 W 900mm  
 D 770mm  
 Code **215680**

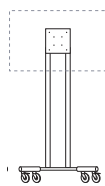

**White stand**  
 Size H 1650mm  
 W 900mm  
 D 770mm  
 Code **215781**

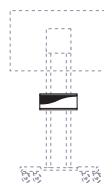

**IR cabinet**  
 Size H 210mm  
 W 550mm  
 D 420mm  
 Beech **215688**  
 Black **215789**

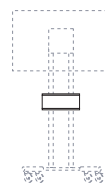

**Standard cabinet**  
 Size H 210mm  
 W 550mm  
 D 420mm  
 Beech **215686**  
 Black **215787**



**Shelf**  
 Size H 30mm  
 W 450mm  
 D 420mm  
 Beech **215682**  
 Black **215783**

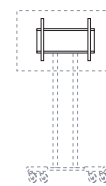

**Universal bracket**  
 Code **215684**

215680 + 215682



215681 + 215787



215688



215686



215783



215684

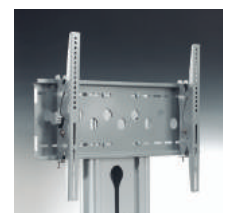

# Projection Screens

- 204 - 205** Freestanding Tripod
- 206 - 209** Freestanding
- 210 - 212** Wall Mounted Manual
- 213 - 221** Wall Mounted Electric
- 222** Accessories
- 223** Fixed Frame
- 224 - 225** Drywipe
- 226** Bespoke Screen Service



# Projection Screens - Freestanding Tripod



ET1002

## Eyeline® Basic tripod screens

Portable projection screen with tripod base and plain matte white cloth

- Entry level folding tripod stand
- Fully height adjustable - see item 'E' in dimension chart
- Variable format ratios up to 1:1 square
- Built-in 'keystone' correction
- Integral carry handle for ease of transportation
- 5 size models
- Plain matte white surface

Height adjustable with pole support



Integrated carrying handle



# EYELINE

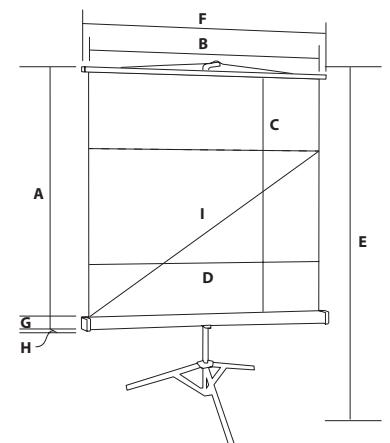

Screen Size	A Height (max)	B Width	View Area	C Height (max)	D Width	Format	Max. Height	Case Size	F Length	G Height	H Depth	Diagonal in video format I	Weight	Code
1250mm	1250mm	1250mm	1250mm	1250mm	Variable	1930mm	1290mm	60mm	60mm	60mm	60mm	61 inch	8.5kg	<b>ET1000</b>
1500mm	1500mm	1500mm	1500mm	1500mm	Variable	2380mm	1540mm	60mm	60mm	60mm	60mm	74 inch	10kg	<b>ET1001</b>
1800mm	1800mm	1800mm	1800mm	1800mm	Variable	2680mm	1840mm	60mm	60mm	60mm	60mm	88 inch	12kg	<b>ET1002</b>
2000mm	2000mm	2000mm	2000mm	2000mm	Variable	2880mm	2040mm	70mm	70mm	70mm	70mm	98 inch	13.5kg	<b>ET1003</b>
2400mm	2400mm	2400mm	2400mm	2400mm	Variable	3080mm	2440mm	70mm	70mm	70mm	70mm	118 inch	18kg	<b>ET1005</b>

## Eyeline® Presenter tripod screens

Portable projection screen with tripod base and matte white cloth with borders which enhance the projected image providing a professional presentation

- Black borders to both sides of screen cloth
- Heavy duty folding tripod stand
- Fully height adjustable - see item 'E' in dimension chart
- Variable format ratios up to 1:1 square
- Built-in 'keystone' correction
- Integral carry handle for ease of transportation
- 5 size models
- Plain matte white surface

Height adjustable with pole support

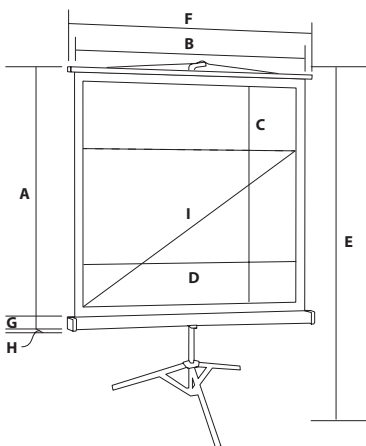

Keystone eliminator



# EYELINE

Screen Size A Height	B Width	View Area C Height	D Width	Format 1:1 maximum	Max. Height E	Case Size F Length	G Height	H Depth	Diagonal in video format I	Weight	Code
1250mm	1250mm	1190mm	1190mm	Variable	1930mm	1290mm	60mm	60mm	58 inch	8.5kg	<b>LT1000</b>
1500mm	1500mm	1440mm	1440mm	Variable	2380mm	1540mm	60mm	60mm	71 inch	10kg	<b>LT1001</b>
1800mm	1800mm	1740mm	1740mm	Variable	2680mm	1840mm	60mm	60mm	86 inch	12kg	<b>LT1002</b>
2000mm	2000mm	1940mm	1940mm	Variable	2880mm	2040mm	70mm	70mm	96 inch	13.5kg	<b>LT1003</b>
2400mm	2400mm	2300mm	2300mm	Variable	3080mm	2440mm	70mm	70mm	113 inch	18kg	<b>LT1005</b>

# Projection Screens - Freestanding

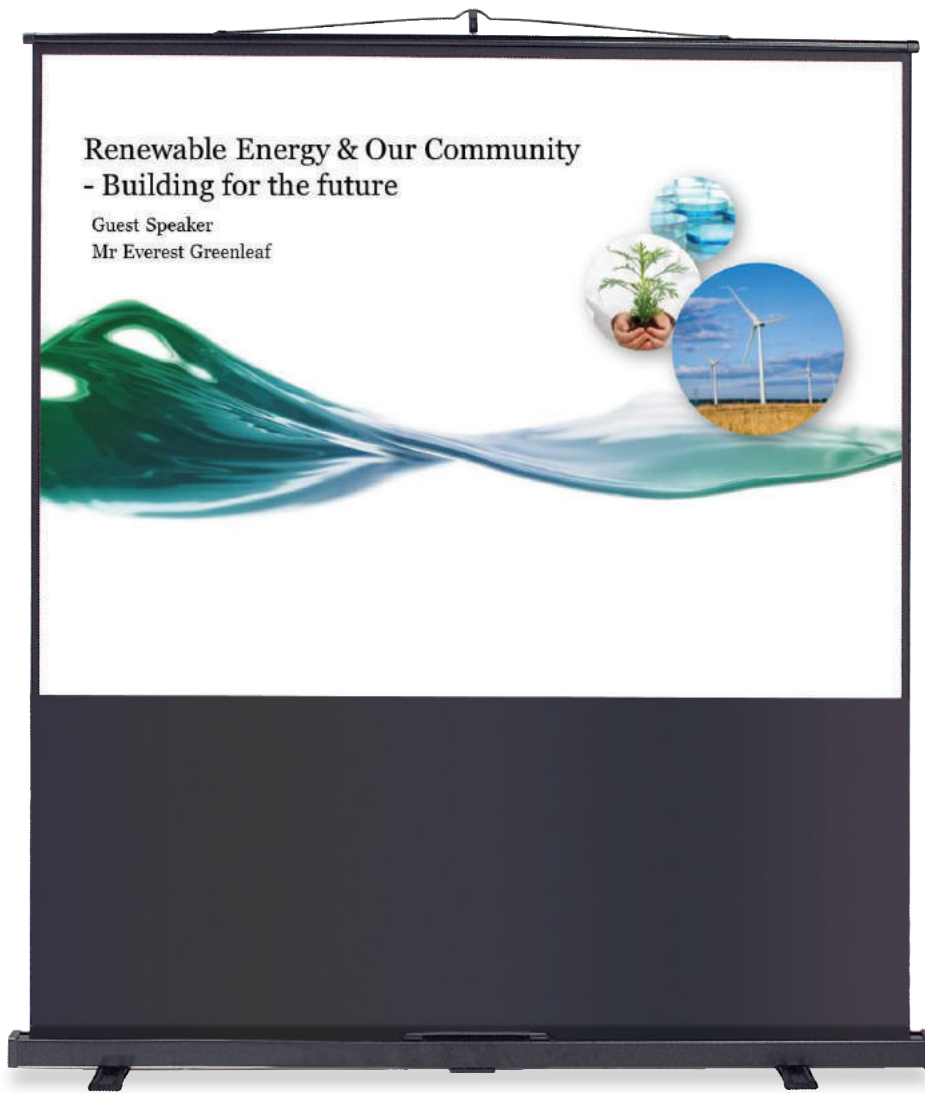

201462V

## Eyeline® floor screens

Portable floor screen with telescopic mast, in a choice of 3 format ratios Square 1:1, Video 4:3 and Widescreen 16:9

- Steel case floor screen with pivoting stabilising feet.
- Fully height adjustable - see item 'E' in dimension chart
- Built-in 'keystone' correction
- Integral carry handle for ease of transportation
- 8 size models
- Plain matte white surface with black borders

Height adjustable with pole support



Integrated carrying handle



Pole support



# EYELINE

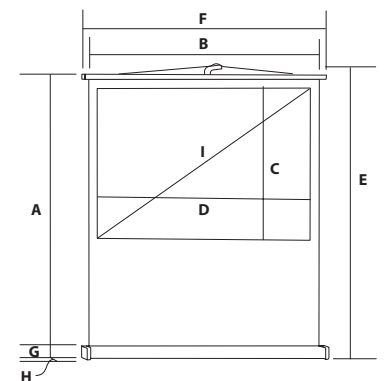

Screen Size A Height	B Width	View Area C Height	D Width	Format	Max. Height E	Case Size F Length	G Height	H Depth	Diagonal I	Weight	Code
2050mm	1500mm	1440mm	1440mm	1:1	2100mm	1535mm	68mm	70mm	NA	10kg	<b>201460</b>
2050mm	1800mm	1740mm	1740mm	1:1	2100mm	1835mm	68mm	70mm	NA	12kg	<b>201462</b>
2050mm	2000mm	1940mm	1940mm	1:1	2100mm	2035mm	68mm	70mm	NA	14kg	<b>201458</b>
2050mm	1500mm	1080mm	1440mm	4:3	2100mm	1535mm	68mm	70mm	71 inch	10kg	<b>201460V</b>
2050mm	1800mm	1305mm	1740mm	4:3	2100mm	1835mm	68mm	70mm	86 inch	12kg	<b>201462V</b>
2050mm	2000mm	1455mm	1940mm	4:3	2100mm	2035mm	68mm	70mm	96 inch	14kg	<b>201458V</b>
2050mm	1800mm	979mm	1740mm	16:9	2100mm	1835mm	68mm	70mm	79 inch	12kg	<b>201462AW</b>
2050mm	2000mm	1091mm	1940mm	16:9	2100mm	2035mm	68mm	70mm	88 inch	14kg	<b>201458AW</b>



## Eyeline® Vertigo scissor floor screens

This stylish Vertigo® deluxe screen has an assisted lift scissor mechanism. With a single handed operation, the screen can simply be raised out of the case to your chosen viewing height

- Tough aluminium case
- Stabilising feet rotate for storage when not in use
- Fully height adjustable - see item 'E' in dimension chart
- Integral carry handle for ease of transportation
- 4 size models
- Plain matte white surface with black borders
- Available in Widescreen 16:9 or 16:10 and Video 4:3 formats

Widescreen format



VG6001

**Extended Range**

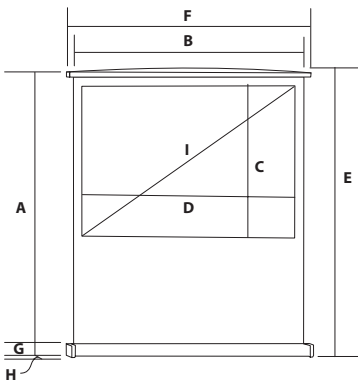

Integrated carrying handle

**EYELINE**



Screen Size A Height	B Width	View Area C Height	D Width	Format	Max. Height E	Case Size F Length	G Height	H Depth	Diagonal I	Weight	Code
1950mm	1200mm	855mm	1140mm	4:3	2000mm	1315mm	90mm	120mm	56 inch	9kg	<b>VG6000</b>
2050mm	1600mm	1155mm	1540mm	4:3	2100mm	1715mm	90mm	120mm	76 inch	10kg	<b>VG8000</b>
2050mm	1600mm	1000mm	1540mm	16:10	2100mm	1715mm	90mm	120mm	72 inch	10kg	<b>VG9001</b>
2050mm	1600mm	866mm	1540mm	16:9	2100mm	1715mm	90mm	120mm	70 inch	10kg	<b>VG6001</b>

Note: VG6000 available only while stocks last



# Projection Screens - Freestanding



201465

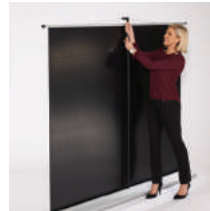

## Eyeline® Movielux floor screens

Contemporary freestanding floor screen with a superior flat screen surface and crisp black borders for unrivalled picture quality

- Unique base design allows the screen to be totally freestanding without the need for stabilising feet
- Case incorporates a carry handle
- Storage area for the telescopic screen support under case
- Widescreen 16:9, 16:10 and video 4:3 formats
- Matte white projection material with black borders

**Extended Range**

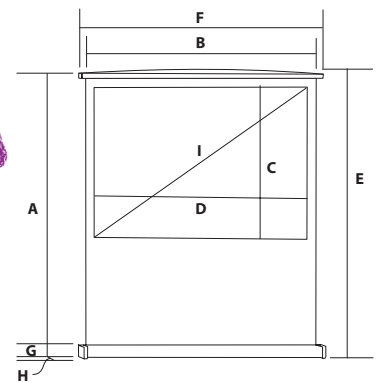

## Eyeline® tabletop projection screen

Portable tabletop projection screen with an impressive 50" (1270mm) diagonal viewing area, yet only weighs 1.65kg.

- Compact case houses the screen support mast
- Integral support feet
- Matte white material delivers superb image quality



Screen Size	A Height	B Width	View Area	C Height	D Width	Format	Max. Height	E	Case Size	F Length	G Height	H Depth	Diagonal	I	Weight	Code
<b>Eyeline® Movielux</b>																
1200mm	1600mm	1160mm	1560mm	4:3	1720mm	1700mm	85mm	245mm	77 inch	10.9kg	<b>201464</b>					
1350mm	1800mm	1310mm	1760mm	4:3	2000mm	1900mm	85mm	245mm	86 inch	12.3kg	<b>201465</b>					
1000mm	1600mm	975mm	1560mm	16:10	1720mm	1700mm	85mm	245mm	72 inch	10.9kg	<b>201470</b>					
1125mm	1800mm	1100mm	1760mm	16:10	2000mm	1900mm	85mm	245mm	81 inch	12.3kg	<b>201471</b>					
900mm	1600mm	860mm	1560mm	16:9	1720mm	1700mm	85mm	245mm	70 inch	10.9kg	<b>201468</b>					
1010mm	1800mm	970mm	1760mm	16:9	2000mm	1900mm	85mm	245mm	79 inch	12.3kg	<b>201469</b>					
<b>Eyeline® Tabletop</b>																
850mm	1055mm	790mm	1015mm	4:3	908mm	1160mm	38mm	65mm	50 inch	1.65kg	<b>SS5500</b>					



## Fast-Fold® deluxe large portable screens

The ultimate large scale portable screen, Fast-Fold® is simple to erect thanks to the quick release catches and sturdy aluminium sections

- Frame sections simply fold out, lock into shape and mount on the T bar feet
- Optional A braces available for greater screen rigidity
- Seamless front or rear projection cloths
- Black backed screen material for higher quality
- Full screen kit includes frame, legs and screen cloth
- Heavy duty wheeled case for storage and mobility
- Drape kits are available and give a more permanently installed look to the screen
- Other sizes and spare front or rear cloths are available to special order

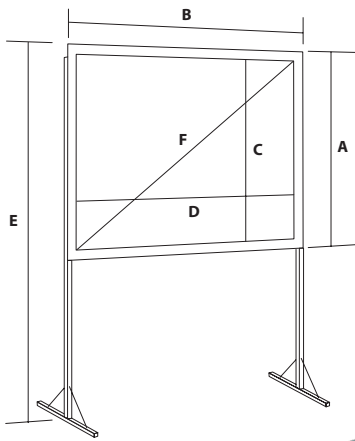

Sturdy transport case



Drape kits available on request

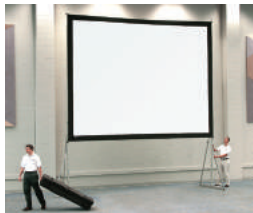

Easy erect frame with...



...quick release catches



Screen Size A Height	B Width	View Area C Height	D Width	Format	Max. Height E	Diagonal F	Weight of Projection kit	Front Projection kit	Front Cloth only	Rear Projection kit	Rear Cloth only
2440mm	2440mm	2338mm	2338mm	1:1	3790mm	NA	34.9kg	<b>288614</b>	<b>234220</b>		
1370mm	1880mm	1271mm	1780mm	4:3	2700mm	86 inch	33.1kg	<b>288602</b>	<b>234214</b>	<b>288623</b>	<b>290802</b>
1830mm	2440mm	1729mm	2338mm	4:3	3160mm	114 inch	34.9kg	<b>288612</b>	<b>234219</b>	<b>288633</b>	<b>290812</b>
2290mm	3050mm	2186mm	2948mm	4:3	3630mm	144 inch	39kg	<b>288617</b>	<b>234225</b>	<b>288638</b>	<b>290817</b>
2740mm	3660mm	2643mm	3558mm	4:3	4090mm	174 inch	42.2kg	<b>288619</b>	<b>234230</b>	<b>288640</b>	<b>290819</b>
3200mm	4270mm	3100mm	4167mm	4:3	5000mm	204 inch	47.6kg	<b>288621</b>	<b>234232</b>	<b>288642</b>	<b>290822</b>
1580mm	2440mm	1475mm	2338mm	16:10	2915mm	109 inch	34.9kg	<b>238304</b>			
1960mm	3050mm	1856mm	2948mm	16:10	3296mm	137 inch	39kg	<b>238306</b>			
2110mm	3660mm	2008mm	3557mm	16:9	3460mm	161 inch	40.8kg	<b>288609</b>	<b>234228</b>	<b>288630</b>	<b>290809</b>
'A' braces to fit any Fastfold™ screen				<b>289762</b>							

# Projection Screens - Wall Mounted Manual



## Eyeline® Basic wall screens

Popular entry level range of manual pull down screens

- Good quality matte white woven cloth
- Easy to mount to wall or ceiling through end cap mounting brackets
- Square 1:1 screen allows for multi format projection
- Optional extension brackets for clearing obstructions
- Pull rod available for use with high mounted screens
- Plain matte white surface
- Entry level basic screen

### NEW SAFETY RETRACTION

All of our manual projection screens now feature a simple slow safety retract mechanism (SSR). Simply release the screen from its open viewing position and let it glide back in to its case unaided. SSR, replacing difficulty with simplicity and safety.

210304E

# EYELINE

Borderless design

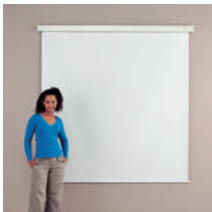

End cap fixing



Optional extension brackets

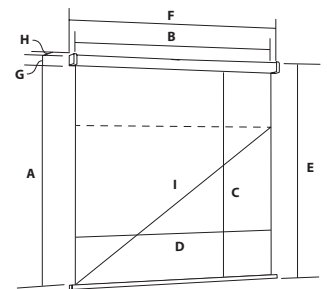

Screen Size A Height (max)	B Width	View Area C Height (max)	D Width	Format 1:1 maximum	Max. Drop E	Case Size F Length	G Height	H Depth	Diagonal in video format I	Weight	Code
1250mm	1250mm	1250mm	1250mm	Variable	1338mm	1290mm	68mm	68mm	61 inch	7kg	<b>210301E</b>
1500mm	1500mm	1500mm	1500mm	Variable	1588mm	1540mm	68mm	68mm	74 inch	8kg	<b>210302E</b>
1800mm	1800mm	1800mm	1800mm	Variable	1888mm	1840mm	68mm	68mm	88 inch	10kg	<b>210303E</b>
2000mm	2000mm	2000mm	2000mm	Variable	2088mm	2040mm	68mm	68mm	98 inch	11kg	<b>210304E</b>
2400mm	2400mm	2400mm	2400mm	Variable	2488mm	2440mm	68mm	68mm	118 inch	13kg	<b>210305E</b>
Extension Bracket		550mm									<b>210710</b>
Pull Rod for higher screens											<b>200713</b>

## Eyeline® Presenter wall screens

Manual pull down projection screen with black borders to all 4 sides that enhances the projected image providing a professional presentation

- Good quality matte white woven cloth
- Square 1:1 screen allows for multi format projection
- Optional extension brackets for clearing obstructions
- Pull rod available for use with high mounted screens
- Wall/ceiling fixing through end caps mounting bracket



210304

### NEW SAFETY RETRACTION

All of our manual projection screens now feature a simple slow safety retract mechanism (SSR). Simply release the screen from its open viewing position and let it glide back in to its case unaided. SSR, replacing difficulty with simplicity and safety.

# EYELINE

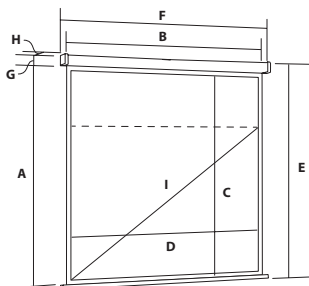

End cap fixing



Manual operation



Optional extension brackets



Screen Size	View Area	Format	Max. Drop	Case Size	Diagonal in	Weight	Code
A Height (max)	C Height (max)	1:1 maximum	E	F Length	video format I		
1500mm	1440mm	Variable	1588mm	1647mm	69 inch	8kg	<b>210302</b>
1800mm	1740mm	Variable	1888mm	1947mm	84 inch	10kg	<b>210303</b>
2000mm	1940mm	Variable	2088mm	2147mm	94 inch	11kg	<b>210304</b>
2400mm	2300mm	Variable	2488mm	2548mm	113 inch	14.5kg	<b>210305</b>
Extension Bracket	550mm						
Pull Rod for higher screens							

Screens include 30mm black borders on all 4 sides except 2400mm model which has 50mm borders.

## Eyeline® Design manual screens

Unique patented click-on / click-off channel fix mounting bracket system is very simple to use, with smaller screens being easily fitted by one person

- Contemporary white triangular case appears smaller than similar sized square cased screens
- Brackets can be placed at virtually any length along the screen case which is ideal when mounting to studwork walls or avoiding wires/pipes
- Both wall and ceiling brackets are included, which are hidden from view when installed
- Black borders to all 4 sides, enhances the projected image, providing a professional presentation
- Additional black cloth to the top of video 4:3 and widescreen 16:9 models for optimal viewing height
- Optional extension brackets are available for clearing an obstruction or keystone adjustment



EMV18W

### NEW SAFETY RETRACTION

All of our manual projection screens now feature a simple slow safety retract mechanism (SSR). Simply release the screen from its open viewing position and let it glide back in to its case unaided. SSR, replacing difficulty with simplicity and safety.



Hook on the screen

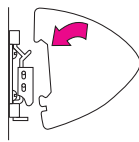

Click into position

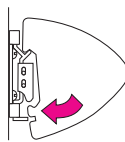

Now ready for use

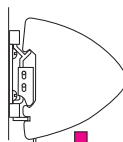

US PATENT: 7.686.265 EUROPEAN PATENT: 1.816.513

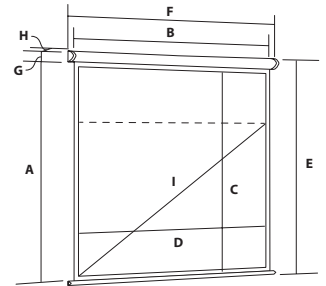

Screen Size A Height	B Width	View Area C Height	D Width	Format	Max. Drop E	Case Size F Length	G Height	H Depth	Diagonal I	Weight	Code
1600mm	1600mm	1540mm	1540mm	1:1	1733mm	1697mm	103mm	95mm	NA	9.5kg	<b>EMS16W</b>
1800mm	1800mm	1740mm	1740mm	1:1	1933mm	1897mm	103mm	95mm	NA	10.5kg	<b>EMS18W</b>
2000mm	2000mm	1940mm	1940mm	1:1	2133mm	2097mm	103mm	95mm	NA	12kg	<b>EMS20W</b>
2400mm	2400mm	2300mm	2300mm	1:1	2560mm	2540mm	130mm	111mm	NA	20kg	<b>EMS24W</b>
3000mm	3000mm	2900mm	2900mm	1:1	3160mm	3140mm	130mm	111mm	NA	27.5kg	<b>EMS30W</b>
1200mm	1600mm	1140mm	1540mm	4:3	1733mm	1697mm	103mm	95mm	75 inch	9.5kg	<b>EMV16W</b>
1350mm	1800mm	1290mm	1740mm	4:3	1933mm	1897mm	103mm	95mm	85 inch	10.5kg	<b>EMV18W</b>
1500mm	2000mm	1440mm	1940mm	4:3	2133mm	2097mm	103mm	95mm	95 inch	12kg	<b>EMV20W</b>
1800mm	2400mm	1700mm	2300mm	4:3	2560mm	2540mm	130mm	111mm	113 inch	20kg	<b>EMV24W</b>
2250mm	3000mm	2150mm	2900mm	4:3	3160mm	3140mm	130mm	111mm	142 inch	27.5kg	<b>EMV30W</b>
900mm	1600mm	840mm	1540mm	16:9	1733mm	1697mm	103mm	95mm	69 inch	9.5kg	<b>EMW16W</b>
1020mm	1800mm	960mm	1740mm	16:9	1933mm	1897mm	103mm	95mm	78 inch	10.5kg	<b>EMW18W</b>
1170mm	2000mm	1110mm	1940mm	16:9	2133mm	2097mm	103mm	95mm	88 inch	12kg	<b>EMW20W</b>
1350mm	2400mm	1250mm	2300mm	16:9	2560mm	2540mm	130mm	111mm	103 inch	20kg	<b>EMW24W</b>
1690mm	3000mm	1590mm	2900mm	16:9	3160mm	3140mm	130mm	111mm	130 inch	27.5kg	<b>EMW30W</b>
Extension Bracket		350mm	<b>EBKT30</b>	Screens include 30mm black borders on all 4 sides except models 2400mm and above which have 50mm borders. 4:3 and 16:9 models have an additional extended black drop.							

## Eyeline® Design electric screens

Electrically operated projection screens are supplied as standard with a 3m cable and wall switch

- Same unique patented click-on / click-off channel fix mounting bracket system as the Eyeline® Design Manual Screen opposite.
- Motor situated on the left hand side when face on
- Requires electrical installation
- Black borders to all 4 sides enhance the projected image, providing a professional presentation
- Additional black cloth to the top of video 4:3 and widescreen 16:9 models for optimal viewing height
- Optional extension brackets are available for clearing an obstruction or keystone adjustment
- Optional key switch, radio frequency or IR remotes

Distinctive triangular case design



EEW18W

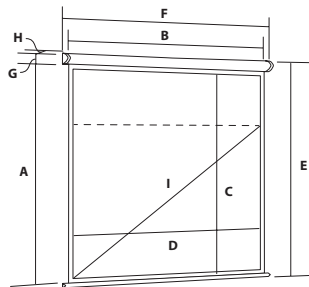

**Extended Range**

Extension Bracket



Screen Size A Height	B Width	View Area C Height	D Width	Format	Max. Drop E	Case Size F Length	G Height	H Depth	Diagonal I	Weight	Code
1600mm	1600mm	1540mm	1540mm	1:1	1733mm	1697mm	103mm	95mm	NA	9.5kg	<b>EES16W</b>
1800mm	1800mm	1740mm	1740mm	1:1	1933mm	1897mm	103mm	95mm	NA	10.5kg	<b>EES18W</b>
2000mm	2000mm	1940mm	1940mm	1:1	2133mm	2097mm	103mm	95mm	NA	12kg	<b>EES20W</b>
2400mm	2400mm	2300mm	2300mm	1:1	2560mm	2540mm	130mm	111mm	NA	20kg	<b>EES24W</b>
3000mm	3000mm	2900mm	2900mm	1:1	3160mm	3140mm	130mm	111mm	NA	27.5kg	<b>EES30W</b>
1200mm	1600mm	1140mm	1540mm	4:3	1733mm	1697mm	103mm	95mm	75 inch	9.5kg	<b>EEV16W</b>
1350mm	1800mm	1290mm	1740mm	4:3	1933mm	1897mm	103mm	95mm	85 inch	10.5kg	<b>EEV18W</b>
1500mm	2000mm	1440mm	1940mm	4:3	2133mm	2097mm	103mm	95mm	95 inch	12kg	<b>EEV20W</b>
1800mm	2400mm	1700mm	2300mm	4:3	2560mm	2540mm	130mm	111mm	113 inch	20kg	<b>EEV24W</b>
2250mm	3000mm	2150mm	2900mm	4:3	3160mm	3140mm	130mm	111mm	142 inch	27.5kg	<b>EEV30W</b>
1250mm	2000mm	1190mm	1940mm	16:10	2133mm	2097mm	103mm	95mm	90 inch	12kg	<b>EEL20W</b>
1500mm	2400mm	1400mm	2300mm	16:10	2560mm	2540mm	130mm	111mm	106 inch	20kg	<b>EEL24W</b>
1875mm	3000mm	1775mm	2900mm	16:10	3160mm	3140mm	130mm	111mm	134 inch	27.5kg	<b>EEL30W</b>
900mm	1600mm	840mm	1540mm	16:9	1733mm	1697mm	103mm	95mm	69 inch	9.5kg	<b>EEW16W</b>
1020mm	1800mm	960mm	1740mm	16:9	1933mm	1897mm	103mm	95mm	78 inch	10.5kg	<b>EEW18W</b>
1170mm	2000mm	1110mm	1940mm	16:9	2133mm	2097mm	103mm	95mm	88 inch	12kg	<b>EEW20W</b>
1350mm	2400mm	1250mm	2300mm	16:9	2560mm	2540mm	130mm	111mm	103 inch	20kg	<b>EEW24W</b>
1690mm	3000mm	1590mm	2900mm	16:9	3160mm	3140mm	130mm	111mm	130 inch	27.5kg	<b>EEW30W</b>
Extension Bracket Accessories see page 222		350mm	<b>EBKT30</b>	Screens include 30mm black borders on all 4 sides except models 2400mm and above which have 50mm borders. 4:3 and 16:9 models have an additional extended black drop.							

# Projection Screens - Wall Mounted Electric

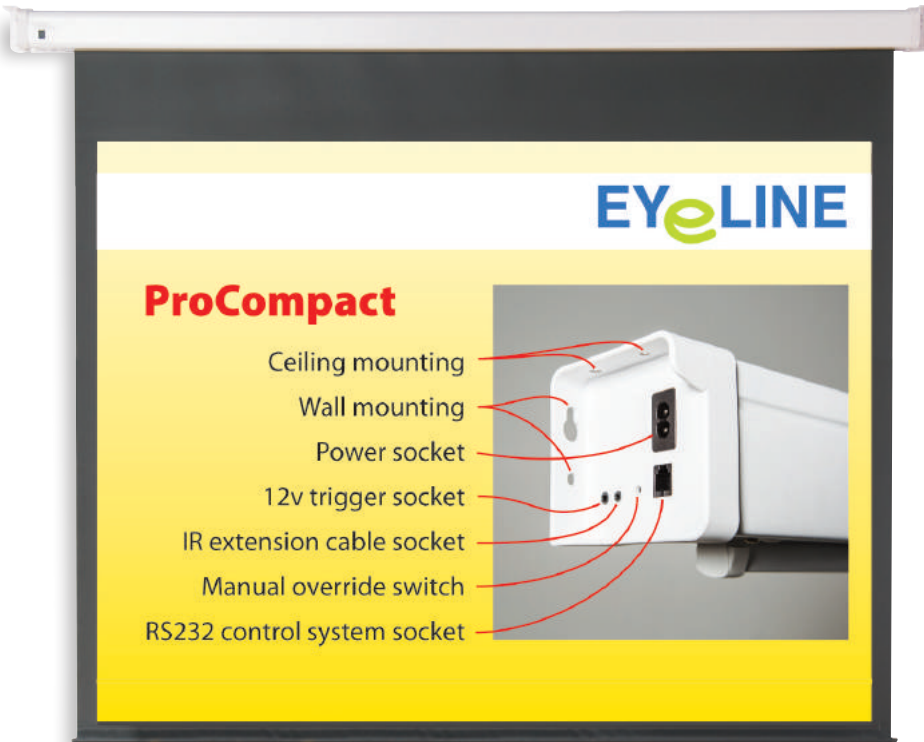

## Eyeline® Pro-compact electric screens

The latest addition to the Eyeline® range of electric screens is supplied with cable, wall plug and infra-red remote for immediate 'plug & play' use

- End cap fixing brackets for wall or ceiling mounting
- 'Fail-safe' override button to side of case
- Matte white projection material
- All popular projection ratios are covered in a wide range of sizes
- Black borders to all 4 sides enhance the projected image, providing a professional presentation
- Additional black cloth to the top of all models for optimal viewing height
- Optional extension brackets are available for clearing an obstruction or keystone adjustment

### ACCESSORY KIT

- 12V trigger cable - 10 metre
- RJ11 extension control cable for RS232
- IR extension cable

EPC4000

Remote operation



Extension Bracket



Accessory Kit

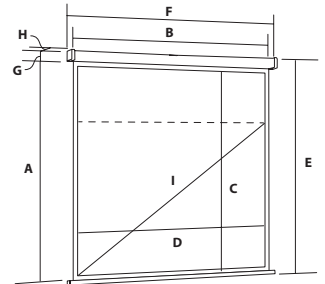

Screen Size A Height	B Width	View Area C Height	D Width	Format	Max. Drop E	Case Size F Length	G Height	H Depth	Diagonal I	Weight	Code
1520mm	1500mm	1440mm	1440mm	1:1	1610mm	1700mm	90mm	90mm	NA	7.2kg	<b>EPC4000</b>
1820mm	1800mm	1740mm	1740mm	1:1	1910mm	2000mm	90mm	90mm	NA	8.8kg	<b>EPC4001</b>
2020mm	2000mm	1940mm	1940mm	1:1	2110mm	2200mm	90mm	90mm	NA	10.6kg	<b>EPC4002</b>
2420mm	2400mm	2340mm	2340mm	1:1	2510mm	2600mm	90mm	90mm	NA	12.4kg	<b>EPC4003</b>
3000mm	3000mm	2900mm	2900mm	1:1	3090mm	3200mm	90mm	90mm	NA	28.5kg	<b>EPC4004</b>
1160mm	1500mm	1080mm	1440mm	4:3	1250mm	1700mm	90mm	90mm	71 inch	10.5kg	<b>EPC6000</b>
1385mm	1800mm	1305mm	1740mm	4:3	1475mm	2000mm	90mm	90mm	86 inch	13.5kg	<b>EPC6001</b>
1535mm	2000mm	1455mm	1940mm	4:3	1625mm	2200mm	90mm	90mm	95 inch	14.5kg	<b>EPC6002</b>
1835mm	2400mm	1755mm	2340mm	4:3	2925mm	2600mm	90mm	90mm	115 inch	18.4kg	<b>EPC6003</b>
2275mm	3000mm	2175mm	2900mm	4:3	2365mm	3200mm	90mm	90mm	143 inch	26.8kg	<b>EPC6004</b>
1368mm	1800mm	1088mm	1740mm	16:10	1458mm	2000mm	90mm	90mm	81 inch	13.5kg	<b>EPC7001</b>
1493mm	2000mm	1213mm	2340mm	16:10	1583mm	2200mm	90mm	90mm	90 inch	12.3kg	<b>EPC7002</b>
1743mm	2400mm	1463mm	2900mm	16:10	2833mm	2600mm	90mm	90mm	109 inch	19.6kg	<b>EPC7003</b>
2113mm	3000mm	1813mm	2900mm	16:10	2203mm	3200mm	90mm	90mm	135 inch	26.2kg	<b>EPC7004</b>
1090mm	1500mm	810mm	1440mm	16:9	1180mm	1700mm	90mm	90mm	65 inch	10.2kg	<b>EPC5000</b>
1259mm	1800mm	979mm	1740mm	16:9	1349mm	2000mm	90mm	90mm	79 inch	13kg	<b>EPC5001</b>
1371mm	2000mm	1091mm	1940mm	16:9	1461mm	2200mm	90mm	90mm	88 inch	14kg	<b>EPC5002</b>
1596mm	2400mm	1316mm	2340mm	16:9	1686mm	2600mm	90mm	90mm	106 inch	17.5kg	<b>EPC5003</b>
1931mm	3000mm	1631mm	2900mm	16:9	2021mm	3200mm	90mm	90mm	131 inch	25.6kg	<b>EPC5004</b>
Extension Bracket		550mm									
Accessory Kit											<b>210710</b> <b>IRC300</b>
Screens include 30mm black borders on all 4 sides, except 3000mm wide screens which have 50mm borders Additional extended black drop is added at top of screen to create maximum drop length.											



## Eyeline® Pro channel fix electric screens

Professional projection screen for operation by IR remote, 12v trigger or central control system

- High quality matte white screen material providing a crisp flat viewing surface
- The view area is framed by 50mm black borders which enhance the image for truly stunning results
- For optimal viewing height, this screen also features an extended black drop
- The screen comes as standard with an infra-red (IR) remote control and IR extension cable for use if the case sensor is obstructed
- 12v trigger with a 10m cable for operation when the projector is powered on/off
- RJ11 (6P6C) cable for connection to a RS232 central control system
- Manual override button is also built in underneath the screen for fail safe operation without remote
- Mount to a wall or ceiling using channel fix brackets, which we can be moved to best fixing points, ie. studs
- No electrical installation required, supplied with a 2.7m cable and plug
- Optional wall switch connects to RJ11 socket



SEV18

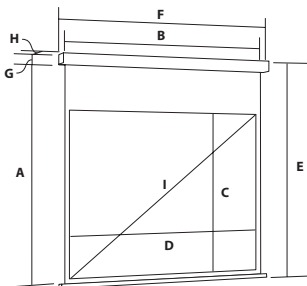

Extension Bracket



Connectivity



IR Sensor and Manual Override



Channel Fix Bracket



Screen Size A Height	B Width	View Area C Height	D Width	Format	Max. Drop E	Case Size F Length	G Height	H Depth	Diagonal I	Weight	Code
1200mm	1560mm	1100mm	1460mm	4:3	1980mm	1700mm	102mm	97mm	72 inch	11kg	<b>SEV15</b>
1380mm	1800mm	1280mm	1700mm	4:3	1980mm	1944mm	102mm	97mm	84 inch	12.5kg	<b>SEV18</b>
1620mm	2130mm	1520mm	2030mm	4:3	1980mm	2270mm	102mm	97mm	100 inch	14.5kg	<b>SEV20</b>
1860mm	2440mm	1760mm	2340mm	4:3	1990mm	2580mm	102mm	97mm	115 inch	16.5kg	<b>SEV24</b>
2390mm	3150mm	2290mm	3050mm	4:3	2640mm	3297mm	102mm	97mm	150 inch	26kg	<b>SEV30</b>
1170mm	1800mm	1070mm	1700mm	16:10	1970mm	1944mm	102mm	97mm	79 inch	10.5kg	<b>SE18ST</b>
1370mm	2130mm	1270mm	2030mm	16:10	1970mm	2270mm	102mm	97mm	94 inch	11.8kg	<b>SE20ST</b>
1560mm	2440mm	1460mm	2340mm	16:10	1960mm	2580mm	102mm	97mm	109 inch	12.3kg	<b>SE24ST</b>
2005mm	3150mm	1905mm	3050mm	16:10	2255mm	3297mm	102mm	97mm	142 inch	26.2kg	<b>SE30ST</b>
990mm	1690mm	890mm	1590mm	16:9	1990mm	1843mm	102mm	97mm	72 inch	11.8kg	<b>SEW16</b>
1060mm	1800mm	960mm	1700mm	16:9	1980mm	1953mm	102mm	97mm	77 inch	12.2kg	<b>SEW18</b>
1250mm	2130mm	1150mm	2030mm	16:9	1950mm	2279mm	102mm	97mm	92 inch	14kg	<b>SEW20</b>
1420mm	2440mm	1320mm	2340mm	16:9	1970mm	2589mm	102mm	97mm	106 inch	16.2kg	<b>SEW24</b>
1600mm	2760mm	1500mm	2660mm	16:9	1950mm	2884mm	102mm	97mm	120 inch	23.4kg	<b>SEW26</b>
1820mm	3150mm	1720mm	3050mm	16:9	2170mm	3297mm	102mm	97mm	138 inch	25.3kg	<b>SEW30</b>
Extension Bracket		350mm	<b>EPB35</b>	Screens include 50mm black borders on all 4 sides. Additional extended black drop is added at top of screen to create maximum drop length.							
Wall Switch RJ11			<b>EPW10</b>								
Accessories see page 222											

# Projection Screens - Wall Mounted Electric

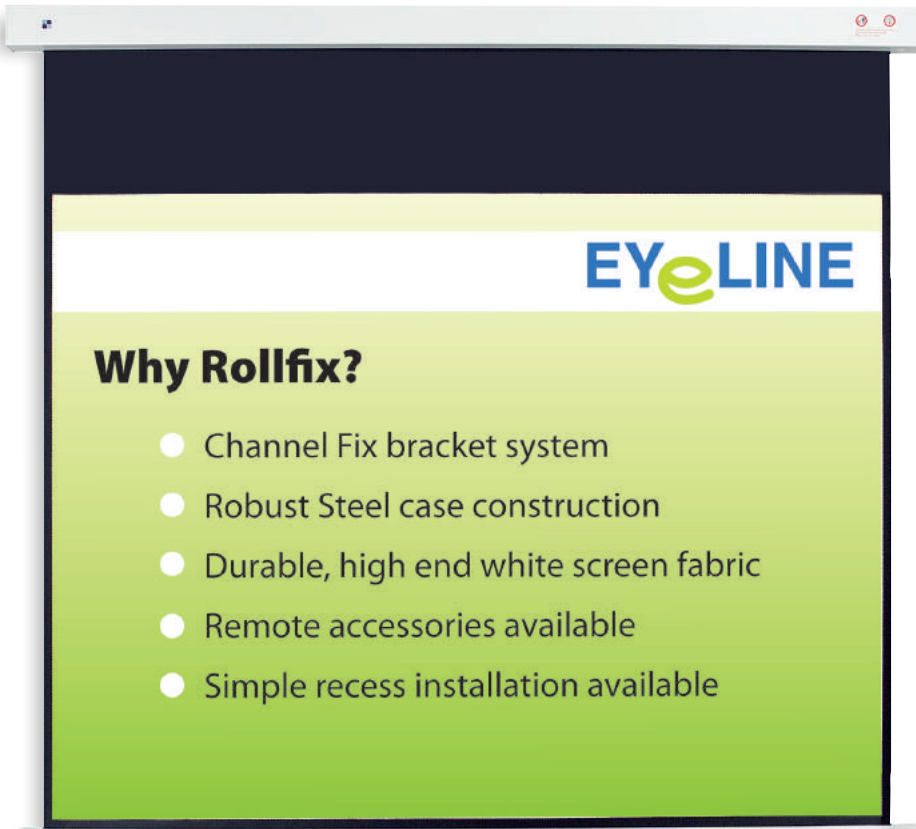

## Eyeline® Rollfix heavy duty electric screens

Deluxe heavy duty range of projection screens with a robust steel housing

- Channel mounting system enabling a fast and easy install (channel length 500mm at each end)
- Hard wearing heavy duty matte white screen fabric for clear and crisp images
- All models have a 300mm extended black drop which ensures optimum viewing
- 40mm black borders to side and bottom
- Requires electrical installation
- Motor situated on the right hand side
- Supplied with wall switch
- For remote control options see page 222

Channel fix mounting



RFV200

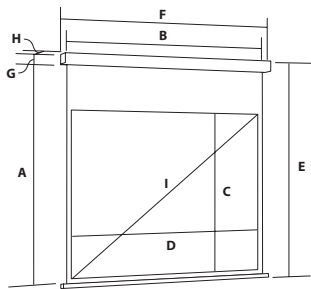

**Extended Range**

In-ceiling option - see opposite page

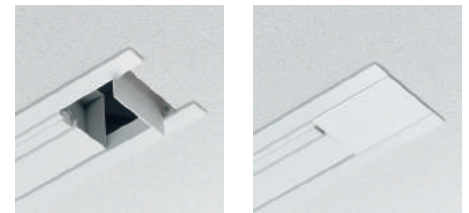

Screen Size A Height	B Width	View Area C Height	D Width	Format	Max. Drop E	Case Size F Length	G Height	H Depth	Diagonal I	Weight	Code
1370mm	1800mm	1290mm	1720mm	4:3	1484mm	1940mm	87mm	87mm	2150mm	12.7kg	<b>RFV180</b>
1520mm	2000mm	1440mm	1920mm	4:3	1634mm	2140mm	87mm	87mm	2400mm	14.1kg	<b>RFV200</b>
1820mm	2400mm	1740mm	2320mm	4:3	1934mm	2540mm	87mm	87mm	2900mm	17.1kg	<b>RFV240</b>
2270mm	3000mm	2190mm	2920mm	4:3	2402mm	3140mm	105mm	105mm	3650mm	25.3kg	<b>RFV300</b>
1160mm	1800mm	1080mm	1720mm	16:10	1274mm	1940mm	87mm	87mm	2031mm	12.4kg	<b>RFST180</b>
1280mm	2000mm	1200mm	1920mm	16:10	1394mm	2140mm	87mm	87mm	2264mm	13.8kg	<b>RFST200</b>
1530mm	2400mm	1450mm	2320mm	16:10	1644mm	2540mm	87mm	87mm	2736mm	16.7kg	<b>RFST240</b>
1910mm	3000mm	1830mm	2920mm	16:10	2042mm	3140mm	105mm	105mm	3446mm	24.8kg	<b>RFST300</b>
1050mm	1800mm	970mm	1720mm	16:9	1164mm	1940mm	87mm	87mm	1975mm	12.3kg	<b>RFW180</b>
1160mm	2000mm	1080mm	1920mm	16:9	1274mm	2140mm	87mm	87mm	2203mm	13.7kg	<b>RFW200</b>
1390mm	2400mm	1310mm	2320mm	16:9	1504mm	2540mm	87mm	87mm	2664mm	16.6kg	<b>RFW240</b>
1720mm	3000mm	1640mm	2920mm	16:9	1852mm	3140mm	105mm	105mm	3349mm	24.7kg	<b>RFW300</b>
Extension Bracket Accessories see page 222		550mm	<b>RFBKT40</b>	Screens include 50mm black borders on all 4 sides. Additional extended black drop is added at top of screen to create maximum drop length.							

## Eyeline® Rollfix in-ceiling recess frame

Convert your Rollfix screens into a discreet in-ceiling projection screen through the use of a recess frame

- Designed for use in rooms with suspended ceilings and where the case need to be hidden from view or where wall mounting is not a suitable option
- The recess frame has a white sleek case design that protects the screen and remains almost completely hidden from view when not in use
- Perfect for a professional and discreet installation, ideal for boardroom and hospitality installations



### Simple 3 step guide for in-ceiling conversion

- 1** Select recess frame designed for use with the width of your selected Rollfix screen (see previous page).
- 2** Recess frame is installed into your suspended ceiling
- 3** Mount your screen within the recess framework and complete electrical installation



For use with Screen Code	Recess frame size (NB NOT hole size)		Recess Frame only, for use with Rollfix screens
	Length	Depth	
<b>RFV180</b>	2186mm	140mm	<b>CR180</b>
<b>RFV200</b>	2386mm	140mm	<b>CR200</b>
<b>RFV240</b>	2786mm	140mm	<b>CR240</b>
<b>RFV300</b>	3386mm	158mm	<b>CR300</b>
<b>RFST180</b>	2186mm	140mm	<b>CR180</b>
<b>RFST200</b>	2386mm	140mm	<b>CR200</b>
<b>RFST240</b>	2786mm	140mm	<b>CR240</b>
<b>RFST300</b>	3386mm	158mm	<b>CR300</b>
<b>RFW180</b>	2186mm	140mm	<b>CR180</b>
<b>RFW200</b>	2386mm	140mm	<b>CR200</b>
<b>RFW240</b>	2786mm	140mm	<b>CR240</b>
<b>RFW300</b>	3386mm	158mm	<b>CR300</b>

NB. Never cut the hole in the ceiling until you have your frame with full instructions. The dimensions stated above are a guide to assess suitability only.



# Projection Screens - Wall Mounted Electric



## Eyeline® large borderless projection screens

Large format screens are common place in halls, churches, theatres and auditoriums, with the average screen size increasing year on year

- A range of large sized electric screens are now available from stock.
- The robust channel fix screen case enables fast secure installation
- Screen is supplied complete with ceiling/wall brackets and electrical wall switch for electrical installation
- Matte white projection surface



### Eyeline® Bespoke Screen Service

We offer a much wider range of screens that are made to order - see page 226 for further information.

# EYELINE

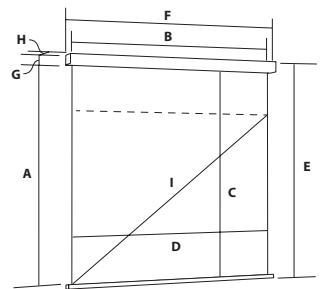

Screen Size A Height (max)	B Width	View Area C Height	D Width	Format	Max. Drop E	Case Size F Length	G Height	H Depth	Diagonal in video format I	Weight	Code
3500mm	3500mm	3500mm	3500mm	1:1	3665mm	3600mm	145mm	147mm	NA	35kg	<b>213511</b>
4000mm	4000mm	4000mm	4000mm	1:1	4165mm	4100mm	145mm	147mm	NA	42kg	<b>213514</b>
2620mm	3500mm	2620mm	3500mm	4:3	2785mm	3600mm	145mm	147mm	172 inch	34kg	<b>213512</b>
3000mm	4000mm	3000mm	4000mm	4:3	3165mm	4100mm	145mm	147mm	197 inch	41kg	<b>213513</b>

Accessories see page 222

## Eyeline® Max projection screens

Large format projection screens with black borders to all 4 sides which enhance the projected image, providing a professional presentation

- Channel fix mounting brackets for wall or ceiling
- Quiet motor during operation
- Matte white projection material
- Video 4:3, Widescreen 16:9 and 16:10 formats
- Additional black cloth to the top of all models for optimal viewing height
- Supplied with bare end cable and wall switch
- Optional remote accessories - see page 222

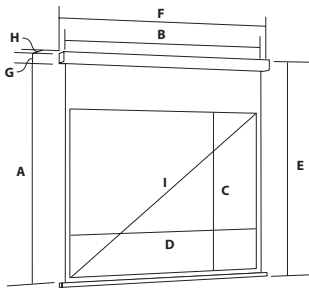

Channel fix mounting



Screen Size A Height	B Width	View Area C Height	D Width	Format	Max. Drop E	Case Size F Length	G Height	H Depth	Diagonal I	Weight	Code
2650mm	3500mm	2550mm	3400mm	4:3	2995mm	3600mm	145mm	147mm	167 inch	30kg	<b>M350V</b>
3020mm	4000mm	2920mm	3900mm	4:3	3365mm	4100mm	145mm	147mm	192 inch	33kg	<b>M400V</b>
3400mm	4500mm	3300mm	4400mm	4:3	3595mm*	4600mm	145mm	147mm	217 inch	36kg	<b>M450V</b>
2230mm	3500mm	2130mm	3400mm	16:10	2875mm	3600mm	145mm	147mm	158 inch	30kg	<b>M350ST</b>
2540mm	4000mm	2440mm	3900mm	16:10	3185mm	4100mm	145mm	147mm	181 inch	33kg	<b>M400ST</b>
2850mm	4500mm	2750mm	4400mm	16:10	3195mm**	4600mm	145mm	147mm	204 inch	36kg	<b>M450ST</b>
2010mm	3500mm	1910mm	3400mm	16:9	2655mm	3600mm	145mm	147mm	154 inch	30kg	<b>M350W</b>
2290mm	4000mm	2190mm	3900mm	16:9	2935mm	4100mm	145mm	147mm	176 inch	33kg	<b>M400W</b>
2570mm	4500mm	2470mm	4400mm	16:9	2915mm**	4600mm	145mm	147mm	199 inch	36kg	<b>M450W</b>

Accessories see page 222

Screens include 50mm black borders on all 4 sides.  
Additional extended black drop: 4:3 models have 200mm, 16:9 and 16:10 have 500mm (except \* 50mm \*\*200mm)

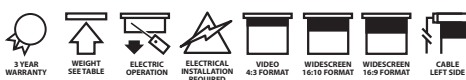

# Projection Screens - Wall Mounted Electric

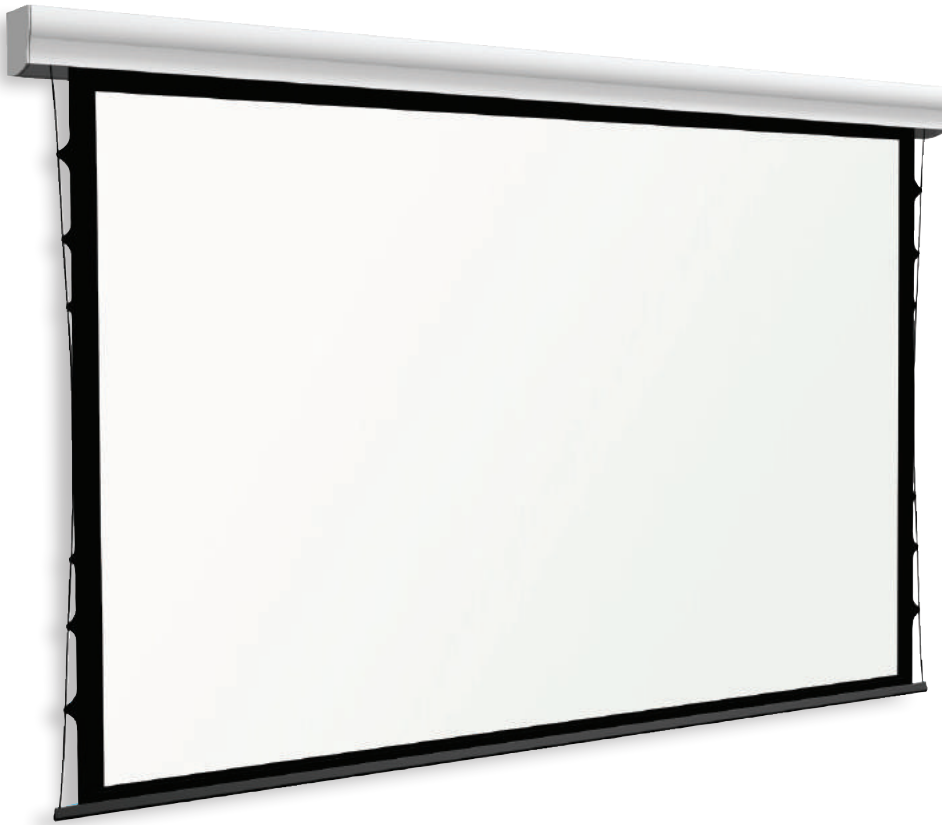

## Eyeline® Wave tab tension screens

Constant tension to the screen edge gives a pure flat ripple free screen without any edge curl

- Superior flat surface which further enhances the projected image
- Available in both front and rear projection materials with matte black borders
- For optimal viewing height, this screen also features an extended black drop
- The sleek and stylish waved aluminium case offers channel fix style mounting for easy installation
- Mount to a wall or ceiling using channel fix brackets
- Supplied with bare end cable and wall switch
- Optional remote accessories - see page 222



# EYELINE

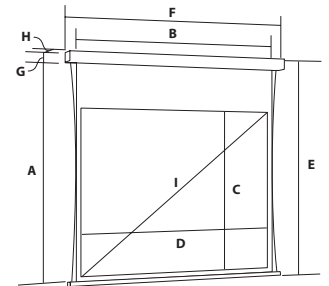

Screen Size A Height	B Width	View Area C Height	D Width	Format	Max. Drop E	Case Size F Length	G Height	H Depth	Diagonal I	Weight	Front Projection	Rear Projection
1470mm	1930mm	1370mm	1830mm	4:3	1813mm	2110mm	143mm	157mm	90"	21kg	<a href="#">GTT183V</a>	<a href="#">GTTR183V</a>
1620mm	2130mm	1520mm	2030mm	4:3	1963mm	2310mm	143mm	157mm	100"	23kg	<a href="#">GTT203V</a>	<a href="#">GTTR203V</a>
1770mm	2330mm	1670mm	2230mm	4:3	2113mm	2510mm	143mm	157mm	109"	24kg	<a href="#">GTT223V</a>	<a href="#">GTTR223V</a>
1930mm	2540mm	1830mm	2440mm	4:3	2273mm	2720mm	143mm	157mm	120"	25kg	<a href="#">GTT244V</a>	<a href="#">GTTR244V</a>
2390mm	3150mm	2290mm	3050mm	4:3	2733mm	3330mm	143mm	157mm	150"	28kg	<a href="#">GTT305V</a>	<a href="#">GTTR305V</a>
2840mm	3760mm	2740mm	3660mm	4:3	3183mm	3940mm	143mm	157mm	180"	35kg	<a href="#">GTT366V</a>	<a href="#">GTTR366V</a>
3150mm	4160mm	3050mm	4060mm	4:3	3493mm	4340mm	143mm	157mm	200"	37kg	<a href="#">GTT406V</a>	<a href="#">GTTR406V</a>
1240mm	1930mm	1140mm	1830mm	16:10	1883mm	2110mm	143mm	157mm	85"	21kg	<a href="#">GTT183T</a>	<a href="#">GTTR183T</a>
1370mm	2130mm	1270mm	2030mm	16:10	2013mm	2310mm	143mm	157mm	94"	23kg	<a href="#">GTT203T</a>	<a href="#">GTTR203T</a>
1630mm	2540mm	1530mm	2440mm	16:10	2273mm	2720mm	143mm	157mm	113"	25kg	<a href="#">GTT244T</a>	<a href="#">GTTR244T</a>
2010mm	3150mm	1910mm	3050mm	16:10	2653mm	3330mm	143mm	157mm	142"	28kg	<a href="#">GTT305T</a>	<a href="#">GTTR305T</a>
2640mm	4160mm	2540mm	4060mm	16:10	3283mm	4340mm	143mm	157mm	188"	37kg	<a href="#">GTT406T</a>	<a href="#">GTTR406T</a>
1130mm	1930mm	1030mm	1830mm	16:9	1773mm	2110mm	143mm	157mm	83"	21kg	<a href="#">GTT183W</a>	<a href="#">GTTR183W</a>
1240mm	2130mm	1140mm	2030mm	16:9	1883mm	2310mm	143mm	157mm	92"	23kg	<a href="#">GTT203W</a>	<a href="#">GTTR203W</a>
1350mm	2330mm	1250mm	2230mm	16:9	1993mm	2510mm	143mm	157mm	101"	24kg	<a href="#">GTT223W</a>	<a href="#">GTTR223W</a>
1470mm	2540mm	1370mm	2440mm	16:9	2113mm	2720mm	143mm	157mm	110"	25kg	<a href="#">GTT244W</a>	<a href="#">GTTR244W</a>
1820mm	3150mm	1720mm	3050mm	16:9	2463mm	3330mm	143mm	157mm	138"	28kg	<a href="#">GTT305W</a>	<a href="#">GTTR305W</a>
2160mm	3760mm	2060mm	3660mm	16:9	2803mm	3940mm	143mm	157mm	165"	35kg	<a href="#">GTT366W</a>	<a href="#">GTTR366W</a>
2380mm	4260mm	2280mm	4060mm	16:9	3023mm	4340mm	143mm	157mm	183"	37kg	<a href="#">GTT406W</a>	<a href="#">GTTR406W</a>

Accessories see page 222

Screens include 50mm black borders on all 4 sides.  
Additional extended black drop: 4:3 models have 200mm, 16:9 and 16:10 have 500mm.

## Eyeline® rear projection electric screens

Rear projection has the benefit of enhanced brightness and contrast, noise reduction and shadow free images

- The area in front of the screen is clear for the presenter and the viewing audience
- Rear projection coral material is used and available with or without black borders
- The robust channel fix screen case enables fast secure installation
- Screen is supplied complete with ceiling/wall brackets
- Electrical wall switch for electrical installation
- Video format (4:3) available with and without black borders
- Video format (4:3) with borders has 200mm black drop, widescreen formats (16:9 and 16:10) have a 500mm black drop

**Extended Range**



# EYELINE

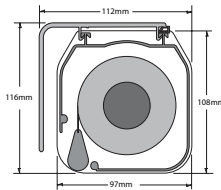
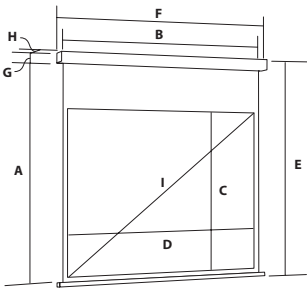

Channel fix mounting

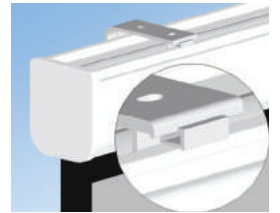
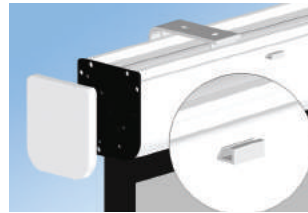

Screen Size A Height	B Width	View Area C Height	D Width	Format	Max. Drop E	Case Size F Length	G Height	H Depth	Diagonal I	Weight	Code
1370mm	1800mm	1370mm	1800mm	4:3 no border	1486mm	1880mm	116mm	112mm	89 inch	12kg	<b>RPE18V</b>
1900mm	2500mm	1900mm	2500mm	4:3 no border	2016mm	2580mm	116mm	112mm	124 inch	17kg	<b>RPE25V</b>
1370mm	1800mm	1270mm	1700mm	4:3	1686mm	1880mm	116mm	112mm	84 inch	12kg	<b>RPE18VB</b>
1900mm	2500mm	1800mm	2400mm	4:3	2216mm	2580mm	116mm	112mm	118 inch	17kg	<b>RPE25VB</b>
1160mm	1800mm	1060mm	1700mm	16:10	1776mm	1880mm	116mm	112mm	79 inch	12kg	<b>RPE18ST</b>
1600mm	2500mm	1500mm	2400mm	16:10	2216mm	2580mm	116mm	112mm	111 inch	17kg	<b>RPE25ST</b>
1050mm	1800mm	950mm	1700mm	16:9	1666mm	1880mm	116mm	112mm	77 inch	12kg	<b>RPE18WB</b>
1450mm	2500mm	1350mm	2400mm	16:9	2066mm	2580mm	116mm	112mm	108 inch	17kg	<b>RPE25WB</b>

Accessories see page 222

Screens include 50mm black borders on all 4 sides (except top 2)  
Additional extended black drop: 4:3 models have 200mm (except top 2), 16:9 and 16:10 have 500mm

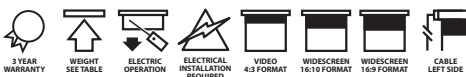

# Projection Screens - Accessories

## Eyeline® electric screen accessories

Please see below range of optional accessories suitable for use with electrically operated Eyeline® projection screens that require hard wiring and is supplied as standard with a bare end cable and wall switch. The below range would be used in place of the wall switch supplied and is suitable for use with the following Eyeline® models:

	PAGE
Eyeline® Design	213
Eyeline® Rollfix	216 - 217
Eyeline® Large Borderless	218
Eyeline® Max	219
Eyeline® Wave Tab Tension	220
Eyeline® Rear Projection	221

### Please Note:

Radio frequency remotes can be used even if there is an obstruction between the remote and the receiver. Infra-red remotes requires a direct line contact with the receiver, also recommended for areas where other radio frequency signals are used to prevent interference. These products require installation by a qualified electrician.



### Eyeline® RF Economy

#### Entry level RF remote

- Screen is operated by radio frequency signal
- Supplied with wall receiver and key fob remote

Code **RF100**



### Eyeline® RF Control

#### Smart control wall switch with integrated RF receiver

- Wall switch with up/down/stop buttons
- Supplied with radio frequency remote
- Switch features integrated 12v trigger and RS232 input

Code **RF300**



### Eyeline® IR Control

#### Smart control wall switch with integrated IR receiver

- Wall switch with up/down/stop buttons
- Supplied with infra-red remote
- Switch features integrated 12v trigger and RS232 input

Code **IR200**



### Somfy® Key Switch

Keeps your screen safe and prevents casual tampering.

- Screen is operated by Key
- 2 keys supplied
- Ideal for education

Code **221022**



### Somfy® Pro Radio Remote

Market leading professional RF remote control system

- Screen operated by radio frequency signal
- Supplied with wall receiver and remote

Code **201236**



### Somfy® Pro Infra-Red Remote

Market leading professional IR remote control system

- Screen operated by infra-red signal
- Supplied with wall receiver, IR sensor and remote

Code **201237**



## Eyeline® frame screens

Semi permanent, always in view screens for dedicated areas such as board rooms, conference rooms, training and home cinema rooms

- Velvet covered aluminium frame is 8cm wide and supplied in sections to fix together with ease
- The screen fabric is tensioned and fitted to the rigid frame giving a superior flat surface
- Velvet covered screens have the benefit of a non-reflective, light absorbing surface that increases the perceived contrast of the image
- Available in a wide range of sizes in video 4:3, widescreen 16:9 and 16:10 formats.

### Bespoke screens

A wider range of fixed frame screens for front and rear projection are available - please ask your representative for further details.

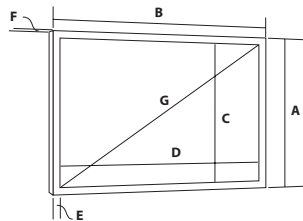
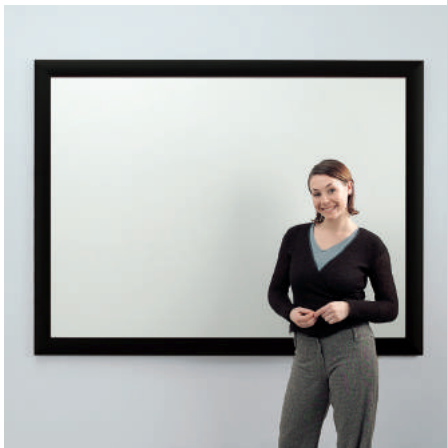

# EYELINE

80mm profile



Screen Size A Height	B Width	View Area C Height	D Width	Format	Frame Size E Width	F Depth	Diagonal G	Weight	Code
1360mm	1760mm	1200mm	1600mm	4:3	80mm	40mm	79 inch	11.85kg	<b>EFS16V</b>
1510mm	1960mm	1350mm	1800mm	4:3	80mm	40mm	89 inch	13.28kg	<b>EFS18V</b>
1660mm	2160mm	1500mm	2000mm	4:3	80mm	40mm	98 inch	14.65kg	<b>EFS20V</b>
1990mm	2560mm	1830mm	2400mm	4:3	80mm	40mm	119 inch	17.98kg	<b>EFS24V</b>
2410mm	3160mm	2250mm	3000mm	4:3	80mm	40mm	148 inch	22.31kg	<b>EFS30V</b>
1410mm	2160mm	1250mm	2000mm	16:10	80mm	40mm	94 inch	13.77kg	<b>EFS2012</b>
1660mm	2560mm	1500mm	2400mm	16:10	80mm	40mm	111 inch	15.98kg	<b>EFS2415</b>
2035mm	3160mm	1875mm	3000mm	16:10	80mm	40mm	139 inch	21.07kg	<b>EFS3018</b>
1060mm	1760mm	900mm	1600mm	16:9	80mm	40mm	72 inch	11.87kg	<b>EFS16W</b>
1180mm	1960mm	1020mm	1800mm	16:9	80mm	40mm	81 inch	12.36kg	<b>EFS18W</b>
1280mm	2160mm	1120mm	2000mm	16:9	80mm	40mm	90 inch	13.34kg	<b>EFS20W</b>
1550mm	2560mm	1390mm	2400mm	16:9	80mm	40mm	109 inch	15.67kg	<b>EFS24W</b>
1850mm	3160mm	1690mm	3000mm	16:9	80mm	40mm	136 inch	20.56kg	<b>EFS30W</b>

# Projection Screens - Drywipe



## Shield® projection whiteboards

The semi-matte drywipe surface of these boards is top grade Japanese vitreous enamel steel guaranteed for 25 years.

NB Due to the heavy duty materials used in the construction of these steel boards, please ensure they are fixed to a solid wall.

- 3 formats - Video 4:3, Widescreen 16:9 or 16:10
- The semi-matte surface diffuses any 'hot spots' but obviously not to the extent of a totally matte projection screen cloth
- Attractive Shield® contoured frame, powder coated black to add the professional touch
- Balanced steel back to avoid distortion
- Concealed corner fixings supplied
- Refresh surface with a cleaning spray periodically

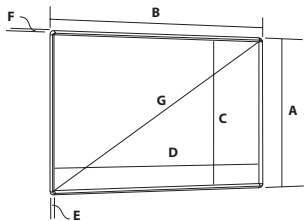

Screen Size A Height	B Width	View Area C Height	D Width	Format	Frame Size E Width	F Depth	Diagonal G	Weight	Code
1221mm	1615mm	1181mm	1575mm	4:3	20mm	23mm	78 inch	27kg	<b>PW1520</b>
1221mm	1930mm	1181mm	1890mm	16:10	20mm	23mm	88 inch	32kg	<b>PW1250</b>
1221mm	2140mm	1181mm	2100mm	16:9	20mm	23mm	95 inch	35kg	<b>PW1120</b>



**New Product**

## WriteOn® glass projection board



Contemporary projection board has a superior silver matte high contrast glass surface to combine projection with dry wipe presentations.

- The board is made from 4mm tempered glass, it is steel backed and can also accept super strength neodymium magnets.
- Attractive chrome mounts fit through the board to float it away from the wall
- Projection area is within the fixings and can be used for both widescreen 16:9 and 16:10 formats
- Refresh surface with a whiteboard cleaning spray periodically.



FOR GLASSBOARD PENS - SEE PAGE 92

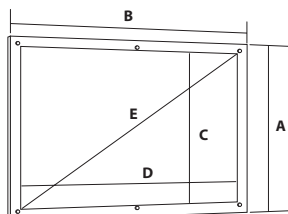

Screen Size	A Height	B Width	View Area - 16:9	C Height	D Width	Diagonal - 16:9	E	View Area - 16:10	C Height	D Width	Diagonal - 16:10	E	Weight	Code
	1200mm	1800mm	956mm	1700mm	77 inch	1062mm	1700mm	79 inch	27kg	<b>GP1218</b>				





## Eyeline® Bespoke Screen Service

### Custom made projection screens

We offer a wide range of custom made mounted projection screens to suit your projection requirements.

Our screens are suitable for a wide range of installations from home cinema installations to high-end corporate installs.

All screens are manufactured to high quality European standards. This page provides an overview of our bespoke offering.

Please contact your representative for further information and to discuss your requirements.

#### Mounted Screens Options

We offer two main styles of bespoke screens: Electrically Operated screens and Fixed Frame screens.

##### 1. Electrically Operated Screens

For wall or ceiling installations. Screens are supplied with a bare end cable from the motor and a wall switch for electrical installation. Electrically operated screens are available up to 7m wide. Also available as:

###### ■ Tab-Tensioning

Screen with a constant tension to the edge to provide a flat surface for superior results.

###### ■ In-Ceiling screens

Screens that are mounted into a suspended ceiling and are hidden when not in use.

###### ■ Multi-Format Screens

Screen with dual motor and surfaces to allow for different projection formats.

#### Projection Formats

We offer solutions for practically any size and format required, with or without extended black borders or drop. The most popular formats are noted below:

###### ■ Square – 1:1 ratio

This traditional format remains widely used in education and church environments as it offers true flexibility in allowing any format to be projected.

###### ■ Video – 4:3 ratio

Is commonly in education, offices and training facilities to allow PowerPoint presentations to fill the screen and ensure text is easily legible. There is a transition over to 16:9 and 16:10 formats as a favourable format although 4:3 is still very popular.

###### ■ Widescreen – 16:10 ratio

A relatively new projection format led by the introduction of a new screen size to accommodate presentations from laptop computers and projectors. This format is increasing in popularity and is mainly used within educational and corporate environments.

###### ■ Widescreen – 16:9 ratio

Popular for home cinema rooms, education where films and images are the main focus and gaming.

##### 2. Fixed Frame Projection Screens

Ideal for semi-permanent installs. Often used for cinema and boardroom applications, or in areas where there is a need for frequent projected information such as attractions and visitor centres. Fixed frame screens are available up to 10m wide.

###### ■ Black Powder Coated

Standard option available for all frame size options.

###### ■ Black Velvet Coated

Velvet frame offers a luxury finish and eliminates reflection from the light source against the frame surface. Velvet coating is available for sizes up to 4m wide.

#### Projection Surfaces

We offer a variety of different projection surfaces to suit your requirements. Below is an overview of the available projection surface options, to suit your requirements:

###### ■ White Ice

Matte white surface for front projection.

###### ■ Home Vision

Heavy duty matte white material for front projection with black back to reduce ambient light show through to improve the projected image.

###### ■ Micro Perforated

This is a matte white projection surface with small holes across the surface to allow for sound penetration when used with speakers behind the screen.

###### ■ Perforated

This surface is also to allow the use of speakers behind a larger screen.

###### ■ Grey High Contrast

For front projection, this screen has a grey surface with a black back and is designed to ensure excellent contrast on darker colours. For viewing films in a dark environment.

###### ■ Coral Rear Projection

This material allows the projection source to be located behind the screen surface.

# EYELINE

# Junior Products

- 228 Whiteboards
- 229 Laptop Whiteboards
- 230 Desktop Easels
- 231 - 232 Mobile Easels
- 232 Paper Hanger
- 233 - 234 Partition Screens



# Junior Products - Whiteboards



42954/MU

## WriteOn® Keycolour whiteboards

### Colourful range of non-magnetic drywipe boards

Double sided; one side plain, one side faint grid with a powder coated aluminium frame. Choice of blue, red, green, yellow or multi-coloured aluminium frame with colour related rounded safety corners and concealed corner fixings. Complete with pen tray.

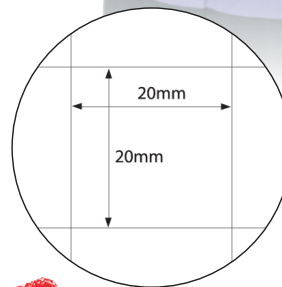

Size H 900mm  
W 600mm

Blue **42932/BL**  
Red **42932/RD**  
Green **42932/GR**  
Yellow **42932/YW**  
Multi-coloured **42932/MU**

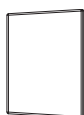

Size H 1200mm  
W 900mm

Blue **42943/BL**  
Red **42943/RD**  
Green **42943/GR**  
Yellow **42943/YW**  
Multi-coloured **42943/MU**

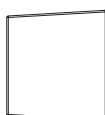

Size H 1200mm  
W 1200mm

Blue **42944/BL**  
Red **42944/RD**  
Green **42944/GR**  
Yellow **42944/YW**  
Multi-coloured **42944/MU**



Size H 1200mm  
W 1500mm

Blue **42954/BL**  
Red **42954/RD**  
Green **42954/GR**  
Yellow **42954/YW**  
Multi-coloured **42954/MU**

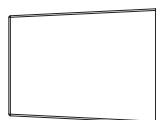

Size H 1200mm  
W 1800mm

Blue **42964/BL**  
Red **42964/RD**  
Green **42964/GR**  
Yellow **42964/YW**  
Multi-coloured **42964/MU**



Size H 1200mm  
W 2400mm

Blue **42984/BL**  
Red **42984/RD**  
Green **42984/GR**  
Yellow **42984/YW**  
Multi-coloured **42984/MU**



FOR DRYWIPE ACCESSORIES - SEE PAGES 89 - 92

## WriteOn® laptop whiteboards

### Hand held whiteboards for classroom use

Double sided whiteboards with Guideline® gridded surface one side and plain surface on the reverse. Smooth radiused corners for safety. Conveniently supplied in packs of six A4 and A3 boards.

### A4 whiteboards

Size H 210mm  
W 297mm  
Pack of 6 **4984A**

### A3 whiteboards

Size H 297mm  
W 420mm  
Pack of 6 **4983A**



## WriteOn® coloured laptop whiteboards

### Brightly coloured magnetic whiteboards

Double sided drywipe whiteboards that have the benefit of also accepting magnets. The chunky multi-coloured ergonomic frame with rounded corner caps makes the board comfortable and safe to use.

### A4 whiteboards

Size H 210mm  
W 297mm  
Pack of 10 **4964A**



## Junior Products - Desktop Easels



JDE101M

### WriteOn® junior desk easels

A compact tabletop easel

A practical easel that can be used by children or staff on classroom tables for drawing, presenting or writing. Supplied with holder for hanging paper or pads; folds for compact storage. There is a choice of satin anodised aluminium or brightly coloured trim. Surface accepts magnets.

#### Aluminium frame

Board size H 500mm  
W 600mm

Code **JDE100M**

#### Multi-coloured frame

Board size H 500mm  
W 600mm

Code **JDE101M**

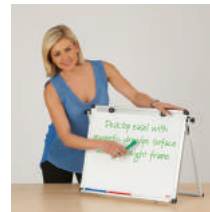

### WriteOn® big book desk easel

Tabletop easel with big book rest

This sturdy yet lightweight easel has a full width ledge and is at the perfect angle for displaying Big Books in class. The landscape board is 600mm x 800mm with a pen tray/ledge running the full width of the board. The hinged rear support ensures the board cannot tilt over for safe classroom use. Aluminium frame with a drywipe surface that also accepts magnets.

Board size H 600mm  
W 800mm  
Code **441001**



**WriteOn®**





## WriteOn® junior mobile whiteboards

Practical floor standing mobile junior whiteboard with integral pen tray

Double sided whiteboard mounted on a mobile frame. Board can pivot and lock at a 40° angle, therefore ideal for resting books or artwork on the full width ledge. 4 castors, 2 locking. Overall height 1300mm. 2 models, both surfaces accept magnets.

### White frame

White coated steel stand with 2 plain aluminium framed whiteboard surfaces.

### Red frame

Red coated steel stand with multi-coloured framed whiteboard that has a 50 x 50mm grid on one side and horizontal lines on the reverse.

### White frame

Board size H 600mm  
W 900mm  
Height 1300mm  
Code **JPM32**

### Red frame

Board size H 600mm  
W 900mm  
Height 1300mm  
Code **JPGL32**



FOR DRYWIPE ACCESSORIES - SEE PAGES 89 - 92



# Junior Products - Mobile Easel and Paper Hanger



## WriteOn® junior big book storage easel

Handy mobile easel with storage tray

Free standing whiteboard easel with steel storage tray to base. Easy to move when angled onto two wheeled legs. The drywipe steel whiteboard measures 900 x 600mm and is ideal for use with big books due to full width pen tray and angled board. Surface accepts magnets

Board size H 900mm  
W 600mm  
Height 1350mm  
Code **BMBM32**



## Trapease® paper hanging system

Ingenious rail for hanging paper or thin card

Simply insert paper and then lift and pull upwards to release. Ideal for displaying childrens artwork or notices. Simple wall attachment via snap fixings or adhesive mountings - both supplied. Trapease rails can be used singly or are designed to butt seamlessly end to end for longer runs. Can be converted to an all white system.



600mm  
Size H 54mm  
W 600mm  
D 22mm  
Code **TE060**



1200mm  
Size H 54mm  
W 1200mm  
D 22mm  
Code **TE120**



1800mm  
Size H 54mm  
W 1800mm  
D 22mm  
Code **TE180**

Push up to attach



Turn over and up...



...to release

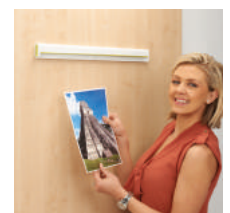



**Extended Range**

## BusyScreen® Curve junior divider screens

A modern range of 32mm thick partition screens that feature rounded upper corners and a rounded edge trim

Available in a range of 6 sizes. The foot design prevents twisting and fits securely into the base of each screen. Each screen is supplied with two stabilising feet. A range of 11 hard wearing woven cloth options. Also available in a wide range of 18 loop nylon colours which accept Velcro® coins for displaying artwork, posters etc.







### TO ORDER:

Please state the product code followed by the fabric colour code required.

### EXAMPLE:

Divider screen 1600 x 1200mm in magenta = **BA1612/MG**

Optional castor feet available in lieu of stabiliser feet. See page 162

					
Size H 900mm W 1000mm	Size H 1200mm W 1000mm	Size H 1200mm W 1200mm	Size H 1200mm W 1600mm	Size H 1450mm W 1200mm	Size H 1600mm W 1200mm
Code <b>BA9010</b>	Code <b>BA1210</b>	Code <b>BA1212</b>	Code <b>BA1216</b>	Code <b>BA1412</b>	Code <b>BA1612</b>

### Woven cloth colours with Black trim - see page 172

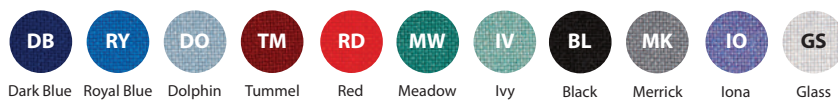

### Traditional loop nylon cloth colours supplied with Black trim - see page 173

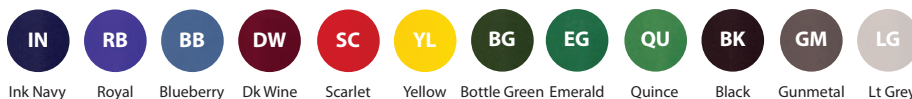

### New loop nylon cloth colours with Grey trim - see page 173



# Junior Products - Partition Screens



DJS64/RD



DJS44/BL

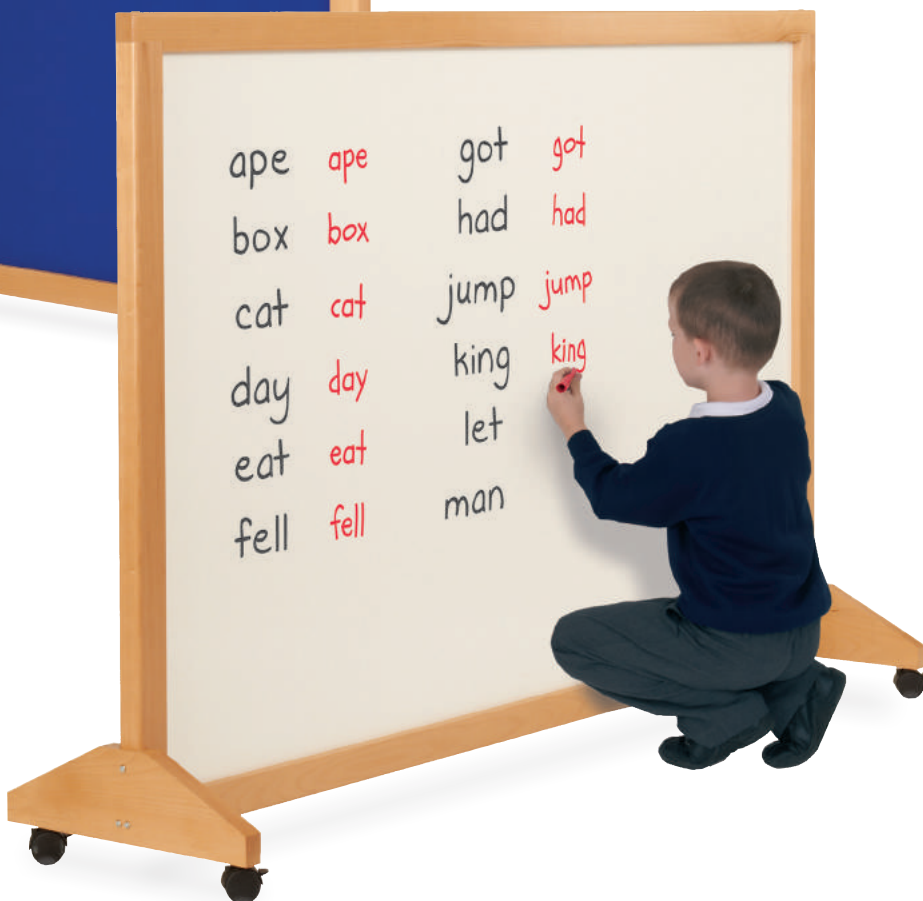

DJS46/WB

## Wood mobile noticeboard/dividers

A range of premium handmade beech framed boards

Double sided boards available in 3 sizes of loop nylon faced noticeboard or drywipe whiteboard. Heavy duty frame made from quality lacquered beech sourced from sustainable forests. Edges of the board are rounded for increased safety. Heavy duty wooden feet ensure stability when freestanding; wheels are provided if mobility is required. Pinnable versions are covered in either red or blue loop nylon material. Whiteboard versions are double sided and have Guideline® gridded surface one side and plain on the reverse.

Whiteboard option

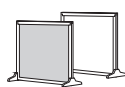

Size H 1200mm  
W 1200mm

Blue **DJS44/BL**  
Red **DJS44/RD**  
Whiteboard **DJS44/WB**

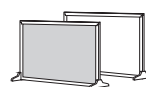

Size H 1200mm  
W 1800mm

Blue **DJS46/BL**  
Red **DJS46/RD**  
Whiteboard **DJS46/WB**

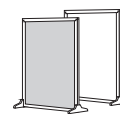

Size H 1800mm  
W 1200mm

Blue **DJS64/BL**  
Red **DJS64/RD**  
Whiteboard **DJS64/WB**

# ColourBox® Storage Furniture

236	How to Order
237	Colour Swatches
238 - 240	Tray Units
241 - 243	Tub Units
244 - 245	Kinderboxes
246 - 247	Quadrant Units
248 - 250	Locking Cabinets
251	Tubs
252	Trays



# ColourBox® Storage Furniture - How to Order

## A new colourful range of storage furniture

ColourBox® Furniture offers you a new and exciting range of vibrant coloured storage furniture to brighten up your teaching environment, domestic or office space.

We aim to offer you top quality products with the added ingredient of a new and unique selection of contemporary colour finishes to compliment the latest trends in decor.

- Made to order to your requirements
- Unique choice of colours and combinations
- Quality - Made to last 10 year Guarantee
- Free direct delivery to most UK mainland addresses
- No assembly required
- Products tested by FIRA



## ColourBox Quality Features

ColourBox furniture products are made in the UK to the highest specifications and come with a 10 year warranty against manufacturing defects.



Each model has been spread load tested to take 100kg



Most units are available on lockable heavy duty wheels with rubber tyres for maximum strength.



All tray storage units use Gratnells® plastic runners, designed to complement the large range of Gratnells® shallow or deep trays in 20 different colours.



Lockable door options for most models prevent casual interference. Locks are supplied with a set of 2 keys, all keys are keyed alike.



All units are manufactured using 18mm MFC throughout and with colour matched ABS edging.



Plinths are available in lieu of wheels to create a static storage solution. Made from real wood with a black finish on coloured units and beech on beech units.



The Tub storage range has cubby holes for use with general purpose plastic tubs. These can also be purchased with traditional wicker baskets or without tubs to suit.



All lockable units have quality safety hinges to prevent sagging.

## How to order

- 1 Simply choose the model of ColourBox® Furniture that best suits your requirements for size and style
- 2 If you would like to secure the contents of the cabinet behind locking doors, choose 'with lockable doors' version
- 3 Choose from mobile option with locking wheels or static version with a solid wood plinth
- 4 Choose the cabinet colour that best suits your environment from the 11 options available, add the colour code after the product code
- 5 Choose the tray or tub colour option to compliment your cabinet, add that code

## Example

ColourBox® 4 column, shallow tray mobile storage with lockable doors in Tomato colour with 24 Translucent trays and doors

Product + Box colour + Tray colour  
code Tomato Translucent  
**CS64D TB TR**

Order code  
**CS64D/TB/TR**

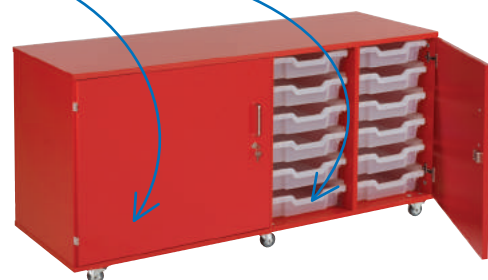

# Colour Swatches - ColourBox® Storage Furniture

## Box colours

Beech range



Beech

Colour range A



Tomato



Blueberry



White



Black

Colour range B



Lime



Bean



Tangerine



Orange



Plum



Grape

**HOW TO ORDER:** Please state the PRODUCT code followed by the BOX colour code and TUB or TRAY colour code.

**EXAMPLE:** 6 x 1 Mobile Tray Storage - see page 238  
 Product code: **CS61**  
 Box colour range A White **WB**  
 Shallow tray from Pop range Mixed **PM**  
**= CS61/WB/PM**



## Gratnells® tray colours - SEE PAGES 252-253

Traditional range



Flame Red



Royal Blue



Grass Green



Sunshine Yellow



Silver

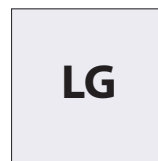

Light Grey

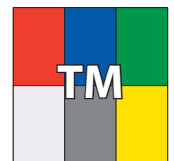

Mixed \*

Pop range



Tropical Orange

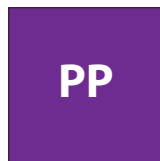

Plum Purple



Fuchsia Pink



Midnight Blue



Cyan Blue



Jolly Lime



Mixed \*

Jelly range



Strawberry



Grape



Blueberry



Kiwi

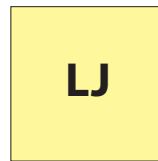

Lemon

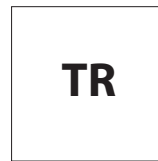

Translucent

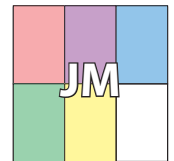

Mixed \*

Domino range



Jet Black



Snow White

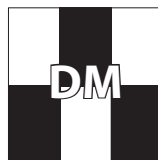

Mixed \*

\* Mixed tray option available for shallow tray units only



## Tub colours and baskets - SEE PAGE 251



Blue



Red



Yellow

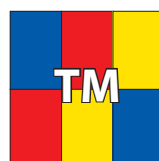

Mixed



Clear

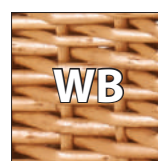

Wicker Baskets

# ColourBox® Storage Furniture - Tray Units



## Shallow tray storage

Tray storage furniture featuring the market leading Gratnells® shallow trays

Choose any combination of beech or 10 striking colours and combine with 20 tray colour options or 4 popular tray mixes. Mobile models with 4 castors, 2 of which lock. Static models on wooden plinths are available for sitting in a more permanent position, coloured units have a black plinth. Optional locking doors to secure the contents.



FOR COLOURS AND HOW TO ORDER - SEE PAGES 236 - 237



6 x 1  
Size H 670mm  
W 370mm  
D 480mm

Mobile **CS61**  
Static **CS61P**

with lockable doors  
Mobile **CS61D**  
Static **CS61PD**



6 x 2  
Size H 670mm  
W 710mm  
D 480mm

Mobile **CS62**  
Static **CS62P**

with lockable doors  
Mobile **CS62D**  
Static **CS62PD**

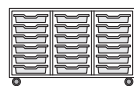

6 x 3  
Size H 670mm  
W 1050mm  
D 480mm

Mobile **CS63**  
Static **CS63P**

with lockable doors  
Mobile **CS63D**  
Static **CS63PD**

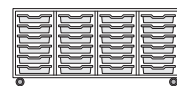

6 x 4  
Size H 670mm  
W 1390mm  
D 480mm

Mobile **CS64**  
Static **CS64P**

with lockable doors  
Mobile **CS64D**  
Static **CS64PD**



8 x 3  
Size H 870mm  
W 1050mm  
D 480mm

Mobile **CS83**  
Static **CS83P**

with lockable doors  
Mobile **CS83D**  
Static **CS83PD**







CD34/TB/TR

## Deep tray storage

Tray storage furniture featuring the popular Grattells® deep trays

Choose any combination of beech or 10 striking colours and combine with 20 tray colour options. Mobile models with 4 castors, 2 of which lock. Static models on wooden plinths are available for siting in a more permanent position, coloured units have a black plinth. Optional locking doors to secure the contents.



FOR COLOURS AND HOW TO ORDER - SEE PAGES 236 - 237



CD31/BK/SW

CS61/WB/JB



Mobile - Locking wheels



Static - Plinth



3 x 1

Size H 670mm  
W 370mm  
D 480mm

Mobile **CD31**  
Static **CD31P**

with lockable doors  
Mobile **CD31D**  
Static **CD31PD**



3 x 2

Size H 670mm  
W 710mm  
D 480mm

Mobile **CD32**  
Static **CD32P**

with lockable doors  
Mobile **CD32D**  
Static **CD32PD**

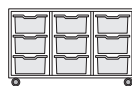

3 x 3

Size H 670mm  
W 1050mm  
D 480mm

Mobile **CD33**  
Static **CD33P**

with lockable doors  
Mobile **CD33D**  
Static **CD33PD**

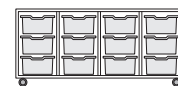

3 x 4

Size H 670mm  
W 1390mm  
D 480mm

Mobile **CD34**  
Static **CD34P**

with lockable doors  
Mobile **CD34D**  
Static **CD34PD**

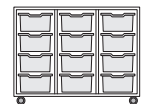

4 x 3

Size H 870mm  
W 1050mm  
D 480mm

Mobile **CD43**  
Static **CD43P**

with lockable doors  
Mobile **CD43D**  
Static **CD43PD**

# ColourBox® Storage Furniture - Tray Units

CM63/PB  
Choose deep and/or shallow trays separately



## Mix and match tray storage

Tray storage furniture combining the popular Gratnells® shallow or deep trays to your own configuration

These storage units come without trays so that you can create your own combination of Gratnells deep and shallow trays. Each deep tray represents the space of 2 x shallow trays. Details of the many tray options available are on pages 252-253.



FOR COLOURS AND HOW TO ORDER - SEE PAGES 236 - 237



Order trays separately  
see pages 252-253



6 x 1 based on all shallow trays

Size H 670mm  
W 370mm  
D 480mm

Mobile **CM61**  
Static **CM61P**

with lockable doors

Mobile **CM61D**  
Static **CM61PD**



6 x 2 based on all shallow trays

Size H 670mm  
W 710mm  
D 480mm

Mobile **CM62**  
Static **CM62P**

with lockable doors

Mobile **CM62D**  
Static **CM62PD**

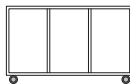

6 x 3 based on all shallow trays

Size H 670mm  
W 1050mm  
D 480mm

Mobile **CM63**  
Static **CM63P**

with lockable doors

Mobile **CM63D**  
Static **CM63PD**

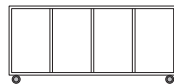

6 x 4 based on all shallow trays

Size H 670mm  
W 1390mm  
D 480mm

Mobile **CM64**  
Static **CM64P**

with lockable doors

Mobile **CM64D**  
Static **CM64PD**

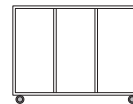

8 x 3 based on all shallow trays

Size H 870mm  
W 1050mm  
D 480mm

Mobile **CM83**  
Static **CM83P**

with lockable doors

Mobile **CM83D**  
Static **CM83PD**



# Tub Units - ColourBox® Storage Furniture



## Tub storage

Tub storage range featuring a cubby hole design, the simple solution to storing small objects

Choose any combination of beech or 10 striking colours and combine with 4 tub colour or wicker basket options. Optional locking doors to secure the contents. Choose from mobile or static models for more permanent siting of the furniture. These units are also available without tubs, see over. Cubby hole dimensions H220 x W280 x D400mm



FOR COLOURS AND HOW TO ORDER - SEE PAGES 236 - 237



CT63P/TG/CL



CT23/LB/BL

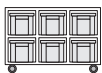

**2 x 3**  
Size H 580mm  
W 940mm  
D 450mm  
Mobile **CT23**  
Static **CT23P**



**3 x 2**  
Size H 810mm  
W 620mm  
D 450mm  
Mobile **CT32**  
Static **CT32P**



**3 x 3**  
Size H 810mm  
W 940mm  
D 450mm  
Mobile **CT33**  
Static **CT33P**

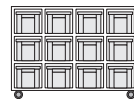

**3 x 4**  
Size H 810mm  
W 1220mm  
D 450mm  
Mobile **CT34**  
Static **CT34P**

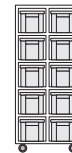

**5 x 2**  
Size H 1220mm  
W 620mm  
D 450mm  
Mobile **CT52**  
Static **CT52P**

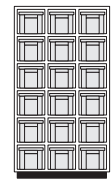

**6 x 3**  
Size H 1530mm  
W 940mm  
D 450mm  
Static **CT63**

with lockable doors  
Mobile **CT23D**  
Static **CT23PD**

with lockable doors  
Mobile **CT32D**  
Static **CT32PD**

with lockable doors  
Mobile **CT33D**  
Static **CT33PD**

with lockable doors  
Mobile **CT34D**  
Static **CT34PD**

with lockable doors  
Mobile **CT52D**  
Static **CT52PD**

with lockable doors  
Static **CT63D**

# ColourBox® Storage Furniture - Tub Units



CH63/OB

## Cubby hole storage

The storage range from the previous page is also available without tubs for use as cubby hole storage

Choose from beech or 10 striking cabinet colours. Static models are available for more permanent siting of the furniture, coloured units have black plinths. Optional locking doors to secure the contents. Sets of 6 tubs or 3 wicker baskets are also available to purchase separately. Cubby hole dimensions H220 x W280 x D400mm

Order tubs or baskets separately see page 251



CT52/BN



CH34PD/TB



CH34/BB (without baskets)

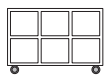

2 x 3  
Size H 580mm  
W 940mm  
D 450mm  
Mobile **CH23**  
Static **CH23P**

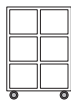

3 x 2  
Size H 810mm  
W 620mm  
D 450mm  
Mobile **CH32**  
Static **CH32P**



3 x 3  
Size H 810mm  
W 940mm  
D 450mm  
Mobile **CH33**  
Static **CH33P**

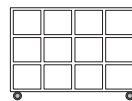

3 x 4  
Size H 810mm  
W 1220mm  
D 450mm  
Mobile **CH34**  
Static **CH34P**



5 x 2  
Size H 1220mm  
W 620mm  
D 450mm  
Mobile **CH52**  
Static **CH52P**



6 x 3  
Size H 1530mm  
W 940mm  
D 450mm  
Static **CH63**

with lockable doors  
Mobile **CH23D**  
Static **CH23PD**

with lockable doors  
Mobile **CH32D**  
Static **CH32PD**

with lockable doors  
Mobile **CH33D**  
Static **CH33PD**

with lockable doors  
Mobile **CH34D**  
Static **CH34PD**

with lockable doors  
Mobile **CH52D**  
Static **CH52PD**

with lockable doors  
Static **CH63D**

## Stepped tub storage

This storage unit has no back so tubs or wicker baskets can be accessed from both sides

For safety the unit is supplied as shown without wheels. Choose any combination of beech or 10 striking colours and combine with 4 tub colours, wicker baskets or with no tubs as a cubby hole unit.

### Stepped unit

H 590mm  
W 970mm  
D 450mm

Cubby hole **CHS6**  
With tubs **CTS6**  
With baskets **CTS6/\*\*/WB**

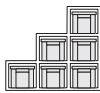

## Cloakroom storage

Two simple designs of storage unit make them ideal for school, office or domestic use

For safety the units are supplied as shown without wheels. Choose any combination of beech or 10 striking colours and combine with 4 tub colours, wicker baskets or with no tubs as a cubby hole unit.



1 x 4

H 310mm  
W 1215mm  
D 450mm

Cubby hole **CH14**  
With tubs **CT14**  
With baskets **CT14/\*\*/WB**



2 x 4

H 530mm  
W 1215mm  
D 450mm

Cubby hole **CH24**  
With tubs **CT24**  
With baskets **CT24/\*\*/WB**



# ColourBox® Storage Furniture - Kinderboxes



CHT22/BH



CKT22D/PB/CL

## Kinderbox tub storage

This unit has 4 compartments to store books as well as 4 large plastic tubs for general storage

It is supplied without doors as standard but optional locking doors are available. Mobile model has heavy duty steel wheels bolted through while static version is built on a plinth. Choose any combination of beech or 10 striking colours and combine with 4 tub colours, wicker baskets or with no tubs as a cubby hole unit.



### Mobile

H 750mm  
W 710mm  
D 490mm

Cubby hole **CHT22**  
With 4 tubs **CKT22**  
With 4 baskets **CKT22/\*\*/WB**



### Static

H 750mm  
W 710mm  
D 490mm

Cubby hole **CHT22P**  
With 4 tubs **CKT22P**  
With 4 baskets **CKT22P/\*\*/WB**

### with lockable doors

Cubby hole **CHT22D**  
With 4 tubs **CKT22D**  
With 4 baskets **CKT22D/\*\*/WB**

### with lockable doors

Cubby hole **CHT22PD**  
With 4 tubs **CKT22PD**  
With 4 baskets **CKT22PD/\*\*/WB**

## Kinderbox tray storage

This unit has 6 compartments to store books as well as 12 shallow or 6 deep slide out Gratnells® trays

Mobile model has heavy duty steel wheels bolted through while static version is built on a plinth. Choose any combination of beech or 10 striking colours and combine with 20 tray colour options.



FOR COLOURS AND HOW TO ORDER - SEE PAGES 236 - 237

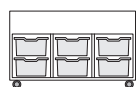

### Mobile

H 710mm  
W 1050mm  
D 480mm

12 Shallow trays **CKS43**  
6 Deep trays **CKD23**



### Static

H 710mm  
W 1050mm  
D 480mm

12 Shallow trays **CKS43P**  
6 Deep trays **CKD23P**

CKS43/BH/TM



CKS43/OB/JL



CKD23/OB/TR

Gratnells

## Slimline kinderbox

Only 300mm deep, this narrow storage unit is ideal where space is limited

4 compartments to display books on top as well as another 4 storage compartments below. Mobile model has heavy duty steel wheels bolted through while static version is built on a plinth. Choose from beech effect or 10 striking colours.



CKT14P/BH



CKT14/BN

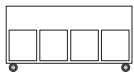

Mobile

H 630mm  
W 1200mm  
D 300mm

Code **CKT14**



Static

H 630mm  
W 1200mm  
D 300mm

Code **CKT14P**



## Kinderbox general purpose storage

This very popular unit has a top that is divided into 6 separate compartments with a multitude of uses

16 small tubs and 4 larger tubs in 4 colours ideal for keeping small, loose items tidy. Heavy duty steel wheels bolted through the carcass of the trolley are standard. Static version has a black solid wood plinth. Choose from beech effect or 10 striking colours.



CKG84/WB



Mobile

H 690mm  
W 900mm  
D 480mm

Code **CKG84**



Static

H 690mm  
W 900mm  
D 480mm

Code **CKG84P**

CKG84/BH



# ColourBox® Storage Furniture - Quadrant Units



CQS2/TB



CQS1/BH



CQS2/TB

CQS3/BH

## Quadrant corner shelving

Practical corner shelving units ideal for use with lever arch files and other general storage requirements

3 size options with 1, 2 or 3 shelves. All units are made from 18mm top quality MFC. Choose from beech effect or 10 striking colours.



1 shelf

H 405mm  
W 384mm  
D 384mm

Code **CQ51**



2 shelf

H 788mm  
W 384mm  
D 384mm

Code **CQ52**



3 shelf

H 1171mm  
W 384mm  
D 384mm

Code **CQ53**



FOR COLOURS AND HOW TO ORDER - SEE PAGES 236 - 237

## Quadrant corner unit

This quadrant shaped unit takes 3 Grattells® translucent quadrant tubs

Designed to be sited in the corner of a room or anywhere with a right angled space to fill. Units can also be positioned together for a flexible layout.



3 tubs

H 588mm  
W 441mm  
D 441mm

Code **CQ31**





## Quadrant semi-circular unit

The semi-circular version takes 6 translucent Gratnells® quadrant tubs

Ideal for placing along a wall or buy 2 to create a static circular unit. Available in 11 unit colours.



6 tubs

H 588mm

W 860mm

D 441mm

Code **CQ32**

*Gratnells*



## Quadrant revolving circular unit

This revolving circular unit takes 12 Gratnells® translucent quadrant tubs

6 locking castors aid manoeuvrability. The whole unit rotates on its base. Ideal for placing centrally in a room. Contrasting grey soft edging protect doorways etc.



12 tubs

H 640mm

W 860mm

D 860mm

Code **CQ34**



# ColourBox® Storage Furniture - Locking Cabinets



CCT44/BK/WB

## Tub and shelf cabinet

This unit has 8 compartments to take large plastic tubs and 4 shelves secured by locking half doors

Heavy duty steel wheels bolted through the carcass to ensure maximum safety. Choose any combination of beech or 10 striking colours and combine with 4 tub colours, wicker baskets or with no tubs as a cubby hole unit. Plinths are available in lieu of the castors for more permanent siting of the furniture. Optional full height locking doors are also available.

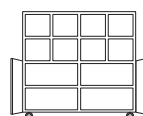

Mobile

H 1050mm  
W 1222mm  
D 450mm

Cubby hole **CHT44**  
With 8 tubs **CCT44**  
With 8 baskets **CCT44/\*\*/WB**

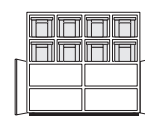

Static

H 1050mm  
W 1222mm  
D 450mm

Cubby hole **CHT44P**  
With 8 tubs **CCT44P**  
With 8 baskets **CCT44P/\*\*/WB**



## Tray and shelf cabinet

This unit has 2 wide shelves as well as 6 shallow or 3 deep slide out Grannells® trays behind a locking door

Mobile models have heavy duty steel wheels bolted through the carcass to ensure maximum safety. Static units have a solid wood plinth. Choose any combination of beech or 10 striking colours and combine with 20 tray colour options. Units are available without trays to specify your own combination - see trays on page 252 and 253.

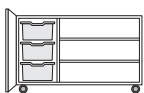

Mobile

H 670mm  
W 1050mm  
D 480mm

6 Shallow trays **CCS6**  
3 Deep trays **CCD3**  
No trays **CCM6**



Static

H 670mm  
W 1050mm  
D 480mm

6 Shallow trays **CCS6P**  
3 Deep trays **CCD3P**  
No trays **CCM6P**

CHT44/BK



CCT44/BK/CL



FOR COLOURS AND HOW TO ORDER - SEE PAGES 236 - 237



CCD3/WB/TO



FOR COLOURS AND HOW TO ORDER - SEE PAGES 236 - 237

CCS6/BH/TM



CCS6/WB/MB



## Small cabinet

This unit has 3 narrow shelves as well as 6 shallow and 2 deep slide out Gratnells® trays behind locking doors

Mobile models have heavy duty steel wheels bolted through the carcass to ensure maximum safety. Static units have a solid wood plinth. Choose any combination of beech or 10 striking colours and combine with 20 tray colour options.

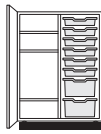
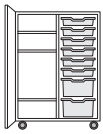

### Mobile

H 1020mm  
W 710mm  
D 490mm

Code **CC62**

### Static

H 1020mm  
W 710mm  
D 490mm

Code **CC62P**



CC62/BB/SW

CC62/BB/SW



FOR COLOURS AND HOW TO ORDER - SEE PAGES 236 - 237

## Mobile combination cabinet

This unit has a height adjustable wide shelf behind 2 locking doors as well as 18 shallow or 9 deep slide out Gratnells® trays

Choose any combination of beech or 10 striking colours and combine with 20 tray colour options. Heavy duty steel wheels for mobility. Optional full height locking doors are also available. Units are available without trays to specify your own combination - see trays on page 252 and 253.



CCS63/LB/TR



### Mobile

H 1250mm  
W 1050mm  
D 490mm

18 Shallow trays **CCS63**  
9 Deep trays **CCD33**  
No trays **CCM63**



CCS63/BH/TM





CWD33/GB/TR

## Static large cabinet

This unit has 2 height adjustable wide shelves as well as 18 shallow or 9 deep slide out Gratnells® trays, all secured behind 2 full height locking doors

For safety reasons, this large cabinet is only available as a static unit. Choose any combination of beech or 10 striking colours and combine with 20 tray colour options. Units are also available without trays to specify your own combination - see trays on page 252 and 253.

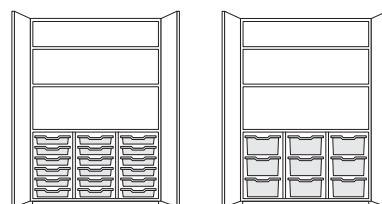

### Static

H 1800mm  
W 1050mm  
D 490mm

18 Shallow trays **CWS63**  
9 Deep trays **CWD33**  
No trays **CWM63**



FOR COLOURS AND HOW TO ORDER - SEE PAGES 236 - 237



CWS63/BH/TR



## Plastic tubs

Purchase spare coloured tubs for your units or buy tubs for cubby hole units purchased earlier

Available in blue, red, yellow or clear. Sold in packs of 6.



### Coloured tubs

Pack of 6

- Yellow **CT6/YW**
- Red **CT6/RD**
- Blue **CT6/BL**
- Clear **CT6/CL**
- Mixed **CT6/TM**

2 blue + 2 red + 2 yellow



Yellow

**YW**



Red

**RD**



Blue

**BL**



Clear

**CL**



## Wicker baskets

Traditional wicker baskets for use with our tub storage units are sold in packs of 3

### Wicker baskets

Pack of 3

Code **CW3**



# ColourBox® Storage Furniture - Trays



## Gratnells® deep trays

Market leading trays available in a wide choice of 20 colours across 4 ranges

For use with all of our shallow tray storage units and our mix and match units. Deep trays in packs of 3. Each deep tray represents the space of 2 x shallow trays. Dimensions H x W x D : 150 x 312 x 427mm

### Traditional range

Pack of 3 deep trays

- Flame Red **F23/FR**
- Royal Blue **F23/RB**
- Sunshine Yellow **F23/SY**
- Grass Green **F23/GG**
- Silver **F23/SL**
- Light Grey **F23/LG**



Flame Red

**FR**



Royal Blue

**RB**



Sunshine Yellow

**SY**



Grass Green

**GG**



Silver

**SL**



Light Grey

**LG**

### Pop range

Pack of 3 deep trays

- Tropical Orange **F23/TO**
- Plum Purple **F23/PP**
- Midnight Blue **F23/MB**
- Fuchsia Pink **F23/FP**
- Cyan Blue **F23/CB**
- Jolly Lime **F23/JL**



Tropical Orange

**TO**



Plum Purple

**PP**



Midnight Blue

**MB**



Fuchsia Pink

**FP**



Cyan Blue

**CB**



Jolly Lime

**JL**

### Jelly range

Pack of 3 deep trays

- Strawberry **F23/SJ**
- Grape **F23/GJ**
- Kiwi **F23/KJ**
- Blueberry **F23/BJ**
- Lemon **F23/LJ**
- Translucent **F23/TJ**



Strawberry

**SJ**



Grape

**GJ**



Kiwi

**KJ**



Blueberry

**BJ**



Lemon

**LJ**



Translucent

**TJ**

### Domino range

Pack of 3 deep trays

- Snow White **F23/SW**
- Jet Black **F23/JB**



Snow White

**SW**



Jet Black

**JB**



## Gratnells® shallow trays

Market leading trays available in a wide choice of 20 colours across 4 ranges with popular mix tray options

For use with all of our shallow tray storage units and our mix and match units. Shallow trays in packs of 6.  
Dimensions H x W x D : 75 x 312 x 427mm



Trad Mixed **TM**



Pop Mixed **PM**



Jelly Mixed **JM**

### Traditional range

Pack of 6 shallow trays

- Flame Red **F16/FR**
- Royal Blue **F16/RB**
- Sunshine Yellow **F16/SY**
- Grass Green **F16/GG**
- Silver **F16/SL**
- Light Grey **F16/LG**
- Mixed **F16/TM**



Flame Red **FR**



Royal Blue **RB**



Sunshine Yellow **SY**



Grass Green **GG**



Silver **SL**



Light Grey **LG**

### Pop range

Pack of 6 shallow trays

- Tropical Orange **F16/TO**
- Plum Purple **F16/PP**
- Midnight Blue **F16/MB**
- Fuchsia Pink **F16/FP**
- Cyan Blue **F16/CB**
- Jolly Lime **F16/JL**
- Mixed **F16/PM**



Tropical Orange **TO**



Plum Purple **PP**



Midnight Blue **MB**



Fuchsia Pink **FP**



Cyan Blue **CB**



Jolly Lime **JL**

### Jelly range

Pack of 6 shallow trays

- Strawberry **F16/SJ**
- Grape **F16/GJ**
- Kiwi **F16/KJ**
- Blueberry **F16/BJ**
- Lemon **F16/LJ**
- Translucent **F16/TJ**
- Mixed **F16/JM**



Strawberry **SJ**



Grape **GJ**



Kiwi **KJ**



Blueberry **BJ**



Lemon **LJ**



Translucent **TJ**

### Domino range

Pack of 6 shallow trays

- Snow White **F16/SW**
- Jet Black **F16/JB**
- Mixed **F16/DM**



Snow White **SW**



Jet Black **JB**



# index

3 Tier Desktop Leaflet Dispensers	132	BusyFold® Light Tabletop XL Display System	149	ColourPlus® Noticeboards continued	
4 Sided Revolving Leaflet Dispensers		BusyFold® Light XL Display System	151	Lockable	33
New Vibrant Colours	127	BusyGrip®	104-107, 110-114	Shield® Design	16
Standard	127	BusyRail® System	100-101	Shield® Design Tamperproof	39
<b>A</b>		BusyScreen® Partitions		Coloured Frame Whiteboards	72-73
A Frames	113-115	Accessories	167	Column 125 Projector Trolley	194
A4 brochure Stand	146	Carnival	168-169	Combi Mobile Easel	99
Acrylic Top Lecterns	184	Classic	164-165	Conference Pro Easel	98
All Clear Leaflet Dispensers	129	Connect	170-171	Covered Noticeboards	See Lockable Noticeboards
All Clear Premier Leaflet Dispensers		Curve	162-163	Crest Leaflet Dispensers	
Desk Top	130	Triple Safety	166	Freestanding	128
Freestanding	131	Colour Swatches	172-173	Wall Mounted	128
Wall Mounted	130	Buzzard Easel	95	Custom Projection Screens	226
Aluminium Framed Noticeboards		<b>C</b>		Cygnets Easel	94
ColourPlus® Felt	9	Certificate Frames	107	<b>D</b>	
Cork	13	Chairs		Desk Easels	230
Dual	15	Annie	183	Display Cases	See Glazed Display Cases
Felt	8	Jane	181	Drywipe Boards	See Write-on® Whiteboards
Fire Retardant	11	Katie	183	Drywipe Maps	83, 88
Fire Retardant Cloth	10	Lena	181	Drywipe Pens and Accessories	89-92
Freestanding	58-59	Lola	182	Dual Faced Whiteboards	69
Recycled	12	Roma	182	Dual Noticeboards	
Resist-a-Flame®	11	Cinco Leaflet Dispensers	134	Aluminium Framed	15
Themeboard	14	Clocks		Combi Mobile	99
Audio Visual Furniture		Big Clock	188	Cork	15, 30
Column 125 Projector Trolley	194	Coloured	189	Eco-Friendly	30
Folding Projector Stand	194	Giant Clock	188	Themeboard	14, 38
Mitre® Conference	199	LED Clock	189	<b>E</b>	
Mitre® Multi-Media	198	World	189	Eco-friendly Noticeboards	
Mitre® Presenter	198	Coat Hooks	192	Contrast	28
Mitre® Presenter XL	198	Coat Rails	191	Cork	25
MM100 Projector Cabinet	197	Coat Stands	190	Dual	30
MM80 Projector Cabinet	195	ColourBox® Storage Furniture		Felt	24
MM90 Projector Cabinet	196	Cloakroom Unit	243	Recycled	29
Secure 110 Cabinet	201	Colour Swatches	237	Tamperproof	31
Secure 160 Cabinet	200	Coloured Tubs	251	Eco-friendly Whiteboards	74
Secure 240 Cabinet	200	Cubby Hole Units	242	Eco-premier Noticeboards	
Secure TV Stand	202	Deep Tray Units	239	Cork	27
Secure MM Projector Trolley	194	Deep Trays	252	Felt	26
<b>B</b>		General Purpose Unit	245	Electric Plug and Play Projection Screens	214
Barrier Systems		How to Order	236	Exhibition Systems	
Retractable	174	Kinderbox Units	244-245	Accessories	160
Rope and Pole	174	Mix and Match Tray Units	240	BusyFix® Coins	160
Bigbook Easels		Quadrant Shelving Units	246	BusyFold® Heavy Duty	153
Desk Easel	230	Quadrant Tub Units	246-247	BusyFold® Heavy Duty Plinths	152
Storage Easel	232	Shallow Tray Units	238	BusyFold® Heavy Duty Tabletop	152
Blackboards		Shallow Trays	253	BusyFold® Light	150
A Frames	114-115	Shelf Cabinets	248-250	BusyFold® Light 1800	154
Freestanding	115	Static Large Cabinet	250	BusyFold® Light Tabletop	149
Wall Mounted	116	Stepped Unit	243	BusyFold® Light Tabletop XL	149
Brochure Stacker	146	Tub Cabinets	248	BusyFold® Light XL	151
BusyFix® Coins for Display Systems	160	Tub Units	241	Colour Swatches	160
BusyFold® Heavy Duty Display System	153	Wicker Baskets	251	Folding	149-154
BusyFold® Heavy Duty Plinths	152	Colour Edged Whiteboards	66-67	Leaflet Holder	160
BusyFold® Heavy Duty Tabletop Display System	152	ColourPlus® Noticeboards		Lights	160
BusyFold® Light 1800 One Piece Displays	154	Aluminium Framed	9	MightyBoard Components	157
BusyFold® Light Display System	150	Colour Swatches	62	MightyBoard Display	156
BusyFold® Light Tabletop Display System	149	Frameless	5	MightyBoard Exhibitor	155



# index

Exhibition Systems continued		Folding Whiteboards	<b>68</b>	Leaflet Display continued	
Multi-board	<b>159</b>	Foyer Whiteboard Stands	<b>81</b>	Panorama	<b>126</b>
OnBoard	<b>158</b>	Frame Projection Screens	<b>223</b>	Pirouette	<b>131</b>
Pole and Panel	<b>155-159</b>	Frameless Noticeboards		Quatro	<b>134</b>
Tabletops	<b>149,152</b>	ColourPlus® Felt	<b>5</b>	Revolving	<b>127, 131, 138, 141, 143, 145</b>
Transporter	<b>160</b>	Felt	<b>4</b>	Revolving Desktop	<b>133</b>
Eyeline® Electrically Operated Projection Screens		Recycled	<b>7</b>	Shelf Style	<b>135</b>
Bespoke Screen Service	<b>226</b>	Resist-a-Flame®	<b>6</b>	Single Pocket	<b>132</b>
Eyeline® Design	<b>213</b>	Frameless Whiteboards	<b>66-67</b>	Steel	<b>142-143</b>
Key Switch	<b>222</b>	Freestanding Noticeboards	<b>54-61</b>	Tabletop	<b>130, 132-133, 140, 144</b>
Large Borderless	<b>218</b>	Freestanding Whiteboards	<b>78-81, 99</b>	Variable Format Tabletop	<b>133</b>
Max	<b>219</b>	<b>G</b>		Wave	<b>139</b>
Pro Channel Fix	<b>215</b>	Glass Information Boards	<b>117</b>	Wire	<b>144-145</b>
Pro-Compact	<b>214</b>	Glass Whiteboards	<b>75</b>	Wooden	<b>135-138</b>
Rollfix Heavy Duty	<b>216</b>	Glazed Display Cases		Leaflet Holder for Display Systems	<b>132</b>
Rollfix In-ceiling Recess Frame	<b>217</b>	Freestanding	<b>187</b>	Lecterns	
Rear Projection	<b>221</b>	Wall Mounted	<b>186</b>	Acrylic Top	<b>184</b>
Remote Controls	<b>222</b>	Gridded Whiteboards	<b>66-67, 69, 78-79, 82</b>	Folding	<b>184</b>
Wave Tab Tension	<b>220</b>	Gridding Tape	<b>91-92</b>	Panel Front	<b>185</b>
Eyeline® Fixed Frame Projection Screens		<b>H</b>		Tabletop	<b>184</b>
Frame Screen	<b>223</b>	Handheld Whiteboards	<b>87, 229</b>	Lights for Display Systems	<b>160</b>
Shield® Projection Whiteboard	<b>224</b>	Handwriting Whiteboards	<b>82</b>	Lined Whiteboards	<b>82</b>
WriteOn® Glass Projection Board	<b>225</b>	Hawk Easel	<b>94</b>	Literature Display	See Leaflet Display
Eyeline® Manually Operated Projection Screens		<b>I</b>		Lockable Noticeboards	<b>31-57</b>
Basic Wall Screen	<b>210</b>	In-Out Boards	<b>119</b>	<b>M</b>	
Eyeline Design	<b>212</b>	In-Out Whiteboards	<b>118</b>	Magnetic Whiteboards	<b>70-71, 73, 75-79</b>
Presenter Wall Screen	<b>211</b>	<b>J</b>		Magnets	<b>92</b>
Eyeline® Portable Projection Screens		Junior Products		Mahogany Leaflet Dispensers	<b>138</b>
Basic Tripod	<b>204</b>	Bigbook Desk Easel	<b>230</b>	Manual Wall Projection Screens	<b>210-212</b>
Fast-Fold®	<b>209</b>	BusyScreen® Round Corner Screens	<b>233</b>	Maps	<b>83, 88</b>
Floor Screen	<b>206</b>	Desk Easels	<b>230</b>	Meeting Room Essentials	
Movielux	<b>208</b>	Junior Bigbook Storage Easel	<b>232</b>	Chairs	<b>181-183</b>
Presenter Tripod	<b>205</b>	Junior mobile Tilting Whiteboard	<b>231</b>	Clocks	<b>188-189</b>
Vertigo Scissor Action	<b>207</b>	Trapease® Paper Hanger	<b>232</b>	Coat Hooks	<b>192</b>
<b>F</b>		Wood Mobile Noticeboards	<b>234</b>	Coat Rails	<b>191</b>
Fast-Fold® Projection Screens	<b>209</b>	WriteOn® Laptop Whiteboards	<b>229</b>	Coat Stands	<b>190</b>
Fire Retardant Cloth Noticeboards		Junior Storage Furniture	See ColourBox® Storage	Glazed Display Cabinets	<b>186-187</b>
Aluminium Framed	<b>10</b>	<b>L</b>		Tables	<b>176-180</b>
Lockable	<b>34</b>	Laptop Whiteboards		Uplighter	<b>188</b>
Also	see Resist-a-Flame®	Colour Frame	<b>229</b>	Mesh Leaflet Dispensers	
Flipchart Easels		Frameless	<b>229</b>	Freestanding	<b>139, 141</b>
BusyRail®	<b>101</b>	Sportsboards	<b>87</b>	Tabletop	<b>140</b>
Buzzard	<b>95</b>	Large Format Projection Screens	<b>218</b>	Wall Mounted	<b>140, 142</b>
Combi Mobile	<b>99</b>	Leaflet Display		MightyBoard Components	<b>157</b>
Conference Pro	<b>98</b>	3 Tier Desktop	<b>132</b>	MightyBoard Display Display System	<b>156</b>
Cygnet	<b>94</b>	4 Sided Revolving	<b>127</b>	MightyBoard Exhibitor Display System	<b>155</b>
Flipchart Pads	<b>102</b>	A4 brochure Stand	<b>146</b>	Mitre Conference Cabinet	<b>199</b>
Flipchart Pens	<b>102</b>	Acrylic	<b>126-133</b>	Mitre Multi-Media Cabinet	<b>198</b>
Hawk	<b>94</b>	All Clear	<b>129</b>	Mitre Presenter Cabinet	<b>198</b>
Trapease®	<b>102</b>	All Clear Premier	<b>130-131</b>	Mitre Presenter XL Cabinet	<b>198</b>
Flipchart Easels continued		Bamboo	<b>136</b>	MM100 Projector Cabinet	<b>197</b>
Tripod	<b>94</b>	Brochure Stacker	<b>146</b>	MM80 Projector Cabinet	<b>195</b>
Ultimate Loop Leg	<b>96</b>	Cinco	<b>134</b>	MM90 Projector Cabinet	<b>196</b>
Ultimate Mobile	<b>97</b>	Crest	<b>128</b>	Mobile Noticeboards	<b>59-61</b>
Floor Projection Screens	<b>206</b>	Mahogany	<b>138</b>	Mobile Whiteboards	<b>78-80</b>
Folding Display	<b>149-154</b>	Mesh	<b>139-142</b>	Movielux Projection Screens	<b>208</b>
Folding Lecterns	<b>184</b>	Oak	<b>138</b>	Multi-board Display System	<b>159</b>
Folding Projector Stand	<b>194</b>	Oak Deluxe	<b>137</b>	Music Stave Whiteboards	<b>82</b>

# index

## N

### Noticeboards

Aluminium Framed	8-15
Colour Swatches	62-64
ColourPlus® Felt	5, 9, 16, 33, 39
Combi Mobile	60
Contrast	28
Cork	13-15, 20, 25, 27, 30-31 38, 52-55, 58
Corridor	36, 42
Dual	15, 30
Eco-premier	26-27
Eco-friendly	24-31
Exterior	52-55
Felt	4-5, 8-9, 14-16, 24, 26, 30-33, 38-39, 58-60
Fire Retardant	6, 10-11, 19, 23, 34-36, 42-43, 45, 47, 49, 51, 59
Foyer	58
Frameless	4-7
Freestanding	54-61
Glazed	48-49
Lift Off Cover	45-47
Lockable	31-57
Loop Nylon	17-18, 21-22, 40-41, 44-46 48-50, 52-58, 61
Mobile	59-61
Multi-banked	22-23, 46-47
Post Mounted	54-55
Recycled	4-5, 7, 12, 24-31, 37
Resist-a-Flame®	6, 11, 19, 23, 35-36 42-43, 45, 47, 49, 51, 59
Shield® Design	16-23, 39-44, 58
Shield® Showcase	48-55, 57
Shield® Sliding Glass Doors	48-49
Shield® Tamperproof	39-44
Tamperproof	31-38
ThemeBoard	14, 21, 38, 44
Top Hinged	36, 42, 50-55, 57
Unframed	4-7
Wood	24-31

## O

Oak Deluxe Leaflet Dispensers	137
Oak Leaflet Dispensers	138
One Piece Folding Display System	154
OnBoard® Display System	158

## P

Panel Front Lecterns	185
Panorama Leaflet Dispensers	126
Partition Screens	See BusyScreen® Partitions
Pavement Displays	112-115
Pinboards	See Noticeboards
Pirouette Leaflet Dispensers	131
Planners	84-85
Pole and Panel Display	155-159
Poster Display	
A Frame Freestanding	113-115
Aluminium framed	104, 108, 110, 112-114

### Poster Display continued

BusyGrip®	104-107, 110-114
Certificate Frames	107
Coloured Frames	105, 109
External	108, 112-114
Freestanding	110-114
Illuminated Freestanding	111
Locking	108
Multiple A4's	107
Shield® with lift off cover	109
Sprung Freestanding	112
Stainless Steel Effect	106
Swinging Freestanding	113
Telescopic Freestanding	110
Wall Mounted	104-109
Wood Effect	106

Printed Whiteboards	82-87
Projection Screens	See Eyeline®
Projector Furniture	194-198

## Q

Quatro Leaflet Dispensers	134
Quick Sign	124

## R

Rear Projection Screens	221
Recycled Noticeboards	

Aluminium Framed	12
Contrast	28
Eco-Friendly	4-5, 7, 24-31
Frameless	7
Lockable	31, 37

### Resist-a-Flame® Noticeboards

Aluminium Framed	11
Frameless	6
Lift Off Cover	47
Lockable	35-36, 42-43, 45, 47, 49, 51
Mobile	59
Shield® Design	19, 23, 42-43
Shield® Showcase	49, 51
Shield® Sliding Glass Doors	49
Shield® Tamperproof	42-43
Tamperproof	35-36
Top Hinged	36, 42, 51
Unframed	6

Retractable Barrier System	174
Revolving Desktop Leaflet Dispensers	133
Revolving Whiteboards	78-79
Rollfix Projection Screens	216-217
Rope and Pole Barrier System	174

## S

Secure 110 Cabinet	201
Secure 160 Cabinet	200
Secure 240 Cabinet	200
Secure TV Stand	202
Secure MM Projector Trolley	194
Shelf Style Leaflet Dispensers	135
Shield® Design Noticeboards	
ColourPlus® Felt	16, 39
Cork	20, 58

### Shield® Design Noticeboards continued

Freestanding	58
Loop Nylon	17-18, 21-22, 40-41
Multi-banked	22-23
Resist-a-Flame®	42-43
ThemeBoard	21, 44
Shield® Design Whiteboards	72-73
Shield® Drywipe Projection Screens	77
Shield® Showcase with hinged doors	
External	52-53
External Post Mounted	54-55
Freestanding	54-55, 57
Loop Nylon	50, 52-55, 57
Resist-a-Flame®	51
Shield® Showcase with lift off cover	
Freestanding	56
Loop Nylon	45-46, 56
Multi-banked	46-47
Resist-a-Flame®	45, 47
Shield® Showcase with sliding doors	48-49
Shield® Design Tamperproof	
ColourPlus® Felt	39
Loop Nylon	40-41, 44
Resist-a-Flame®	42-43
Resist-a-Flame® Corridor	42
Stock options	40
ThemeBoard	44
Showpoint Door/Desk Signs	120
Showpoint In-Out Signage	119
Showpoint Sign Frames	121
Showpoint Wall Sign	122-123
Signage	
Quick Sign	124
Showpoint Door/Desk Signs	120
Showpoint In-Out Signage	119
Showpoint Sign Frames	121
Showpoint Wall Sign	122-123
Single Pocket Leaflet Dispensers	132
Sliding Rail System	100-101
Spacesaver Whiteboards	68
Sportsboard Whiteboards	
Wall mounted	86
Hand Held	87
Steel Leaflet Dispensers	143
Storage Furniture	See ColourBox® Storage

## T

Tables	
EasyFold®	178
Folding	178-180
Meeting Room	176-177
Round	176
Tilt Top	179
Trestle	180
Tabletop Lecterns	184
Tabletop Partitions	See Busyscreen® Partitions
Tabletop Projection Screens	208
Tamperproof Noticeboards	31-57

# index

ThemeBoard Noticeboards		Whiteboards	See WriteOn® Whiteboards	WriteOn® Whiteboards continued	
Aluminium Framed	<b>14</b>	Whiteboard Planners	<b>84-85</b>	Freestanding	<b>78-81</b>
Shield® Design	<b>21</b>	Wire Leaflet Dispensers		Glass	<b>75, 117</b>
Shield® Design Tamperproof	<b>44</b>	Freestanding	<b>145</b>	Gridded	<b>66-67, 69, 78-79, 82</b>
Tamperproof	<b>38</b>	Tabletop	<b>144</b>	Gridding Tape	<b>91-92</b>
Timeminder® Whiteboards	<b>83-85</b>	Wall Mounted	<b>144</b>	Handheld	<b>229</b>
Transporter for Display Systems	<b>160</b>	Wood Framed Noticeboards		Handwriting	<b>82</b>
Trapease Paper Hanger	<b>102</b>	Eco Premier	<b>26-27</b>	In-Out	<b>83</b>
Tray Storage Furniture	<b>238-240, 244, 248-250</b>	Eco-friendly	<b>24-25, 28-30</b>	Lined	<b>82</b>
Triple Safety Partitions	<b>166</b>	Eco-friendly Tamperproof	<b>31</b>	Magnetic	<b>70-71, 73, 75-79</b>
Tripod Projection Screens	<b>204-205</b>	Mobile	<b>61</b>	Magnets	<b>92</b>
Trophy Cases	See Glazed Display Cases	Wood Framed Whiteboards	<b>61, 74</b>	Maps	<b>83, 88</b>
Tub Storage Furniture	<b>241-244, 246-247</b>	Wood Mobile Noticeboards	<b>61</b>	Mobile	<b>78-80</b>
TV Furniture	<b>198-202</b>	WriteAngle® Whiteboards	<b>79</b>	Music Staves	<b>82</b>
<b>U</b>		WriteOn® Glass Drywipe Projection Screens	<b>225</b>	Pens	<b>89</b>
UK Outline Map Dry-wipe	<b>83</b>	WriteOn® Signage		Planners	<b>83-85</b>
Ultimate Loop Leg Easel	<b>96</b>	A Frames	<b>114-115</b>	Printed	<b>82-88</b>
Ultimate Mobile Easel	<b>97</b>	Blackboards	<b>114-117</b>	Projection Screen	<b>224-225</b>
Unframed	See Frameless	Freestanding Blackboards	<b>114-115</b>	Revolving	<b>78-79</b>
Uplighter	<b>188</b>	Freestanding Whiteboards	<b>78-81</b>	Shield® Design	<b>72-73</b>
<b>V</b>		Glassboards	<b>75, 117</b>	Spacesaver	<b>68</b>
Variable Format Leaflet Dispensers	<b>133</b>	WriteOn® Whiteboards		Sportsboards	<b>86-87</b>
Vertigo® Projection Screens	<b>207</b>	Accessories	<b>89-92</b>	Timeminder®	<b>83-85</b>
Vitreous Enamel Steel Whiteboards	<b>71</b>	Aluminium Framed	<b>68-71</b>	UK Outline Map Dry-wipe	<b>83</b>
<b>W</b>		Cleaner	<b>89-90</b>	Vitreous Enamel Steel	<b>71</b>
Wave Leaflet Dispensers	<b>139</b>	Colour Edged	<b>66-67</b>	Whiteboard Wall	<b>67</b>
Wave Tab Tensioned Projection Screens	<b>220</b>	Coloured Frame	<b>72-73, 228</b>	Wood Framed	<b>74</b>
Whiteboard Accessories		Dual Faced	<b>69</b>	WriteAngle®	<b>79</b>
Cleaner	<b>89-90</b>	Eco-friendly	<b>74</b>		
Erasers	<b>90</b>	Erasers	<b>90</b>		
Gridding Tape	<b>91-92</b>	Folding	<b>68</b>		
Magnets	<b>92</b>	Foyer	<b>81</b>		
Pens	<b>89</b>	Frameless	<b>66-67</b>		



Available from

t: 0203 865 2007

e: [sales@cerintxpress.com](mailto:sales@cerintxpress.com)

[www.cerintxpress.com](http://www.cerintxpress.com)